

DIGITAL PHOTOTRANSISTOR
OPTOISOLATOR AND ITS
RESPECTIVE APPLICATIONS

BRYAN KERSTETTER

DAVID SANTIAGO

THE DIGITAL PHOTOTRANSISTOR OPTOISOLATOR (DPO)

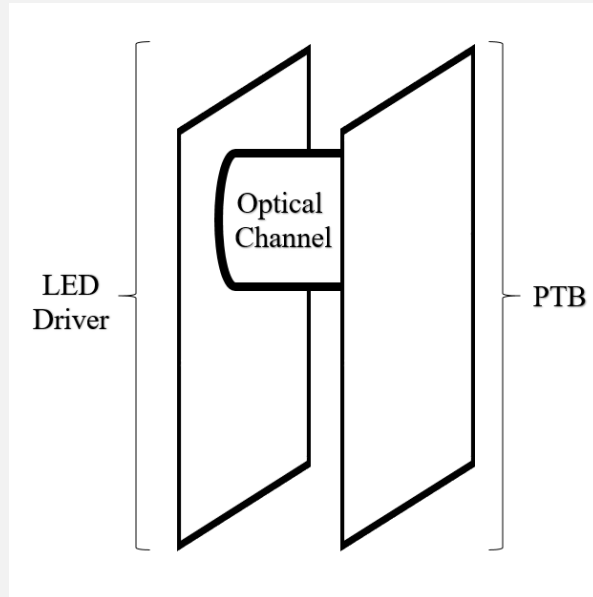

- An optoisolator is an optoelectronic device that transmits signals between two separate electrical circuits by light (while providing electrical isolation).
- Optoisolators require a light source and a light sensor. Optoisolators can be classified by their source-sensor pair.
 - The DPO can be classified as a LED-phototransistor optoisolator
- The design of the DPO required the design of two separate PCBs.
 1. The LED Driver: Converts an electrical signal into a light signal
 2. The Phototransistor Board (PTB): Converts a light signal into an electrical signal
- The two PCBs can then face each other such that an optical channel is formed in between them.
- Both the input and output signals of the DPO are digital signals.

LIGHTING AN LED

- Two approaches can be used to light an LED
 1. Current-Limiting Resistor
 2. Current Source
- A drawback of a current limiting resistor is that the current provided to the LED is dependent upon the supply voltage. As the supply voltage varies the current through the LED varies as well.
- A current source provides consistent current to the LED – independent of the supply voltage
- A current source was decided to be the approach used in the design of the LED Driver.

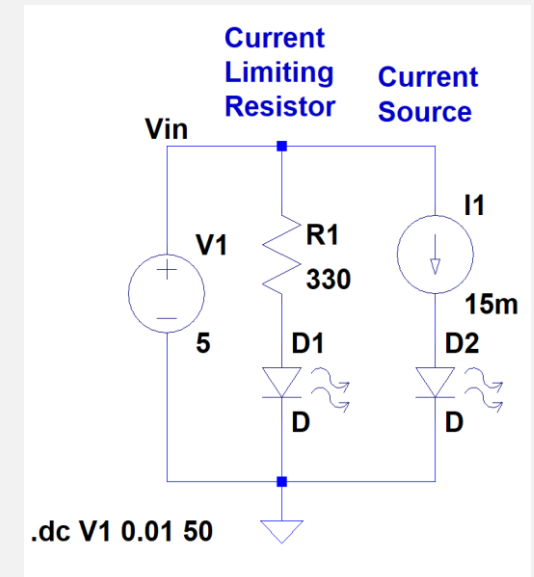
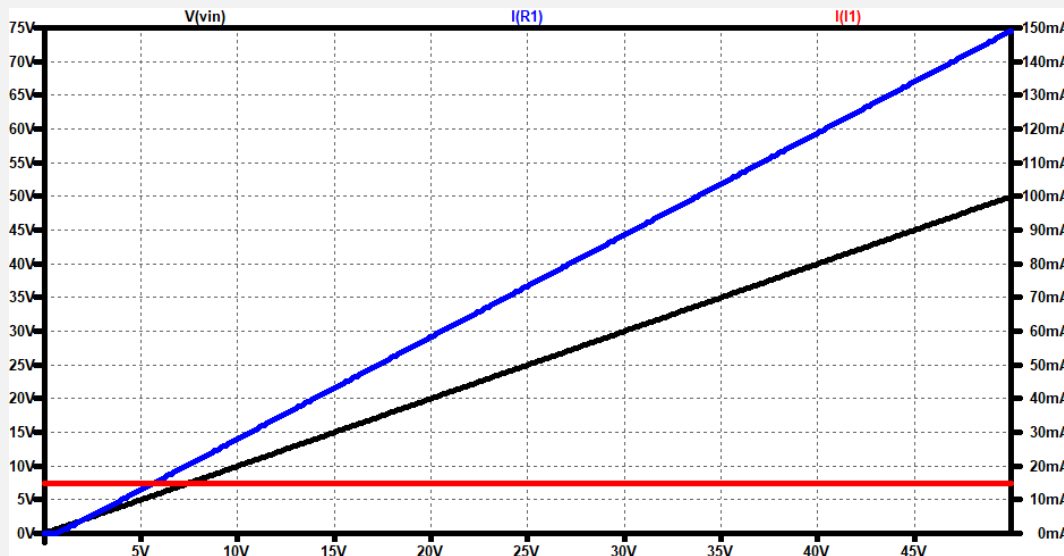

LED DRIVER CIRCUIT

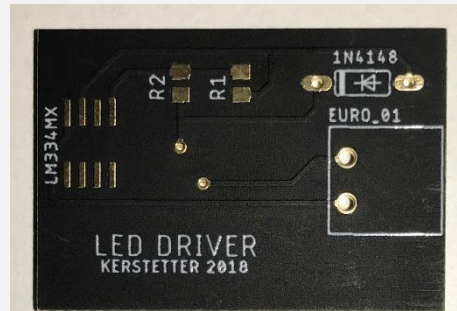
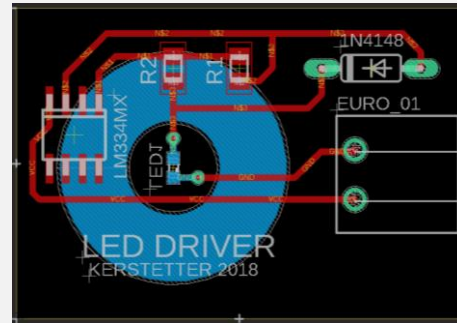
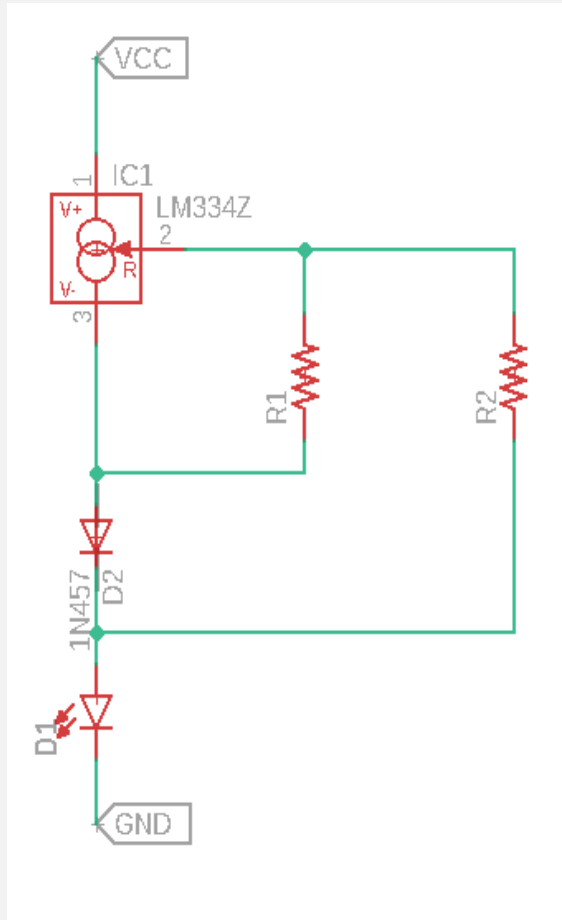

- A LM334 IC can be used to create a constant current source. This will allow us to achieve similar results as seen in the hypothetical current source described previously.
- The LM334 can also be used as a temperature sensor. Therefore temperature is a variable to consider when designing a LM334 current source. Certain implementations of a LM334 current source, result in a current source that varies with temperature.
- A zero temperature coefficient current source can be created with the LM334 and a diode with a specific temperature coefficient.
 - This creates a current source that is independent of temperature

SETTING CURRENT

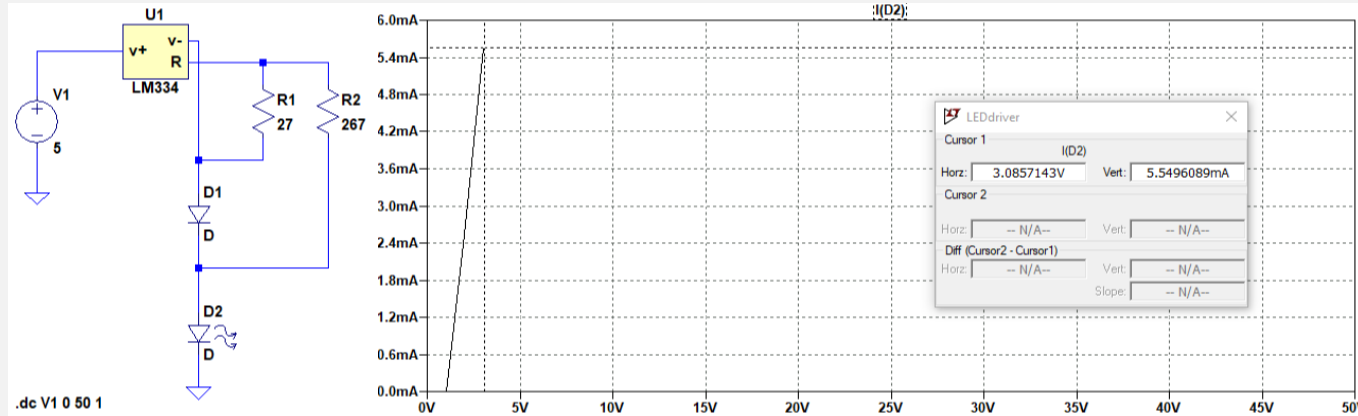

- The current through the LED can be set by the resistance values R1 and R2.
- For example to supply the current with ~5mA, calculations determined R1 to be 27 Ω and R2 to be 267 Ω.
- Both simulation and experimental results show that, during a DC sweep, once a certain threshold voltage is reached a relatively non changing current will be applied to the LED.
- This current voltage relationship allows our LED Driver's supply voltage to be within a large range.

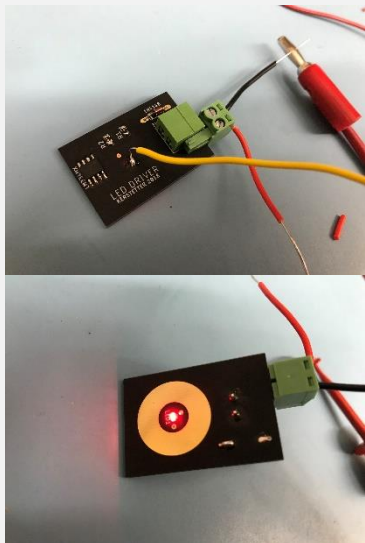

V	I
0 V	0mA
4.5 V	5.394 mA
31.6 V	5.507 mA

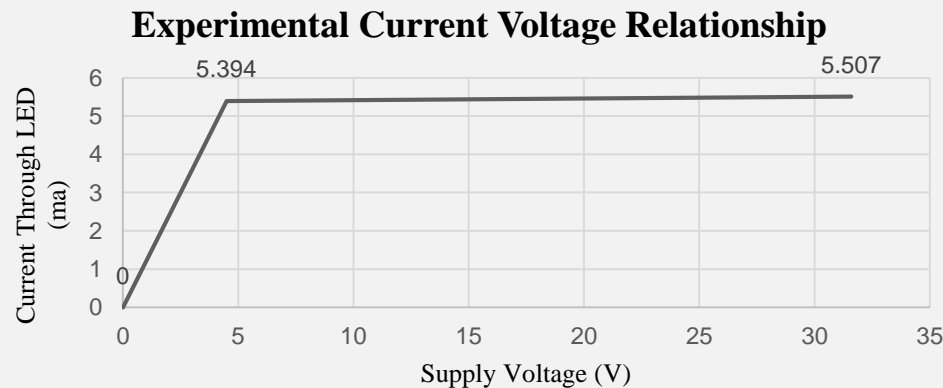

PTB CIRCUIT

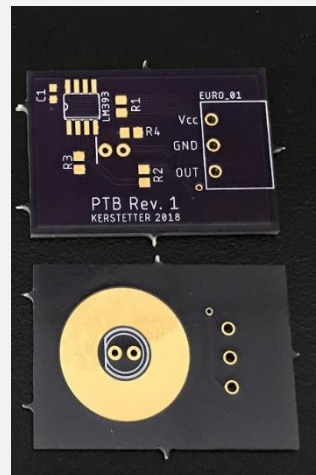
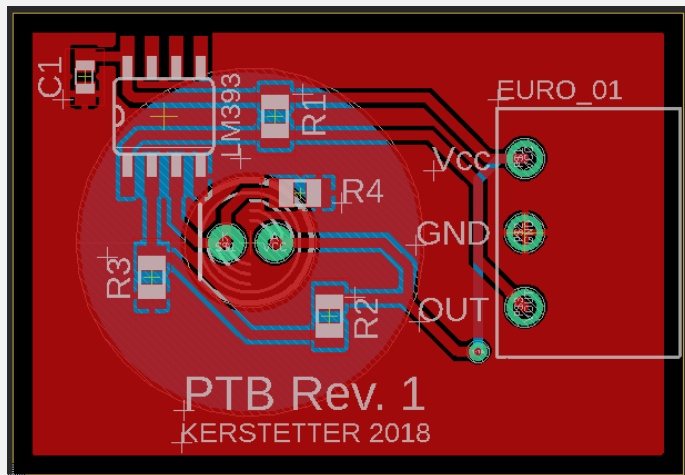
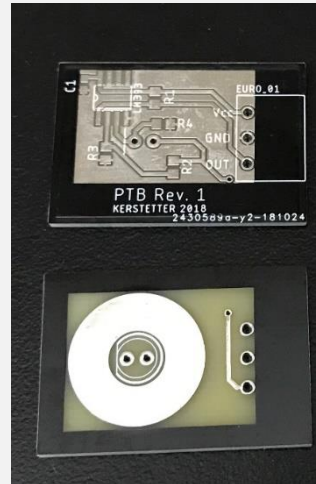
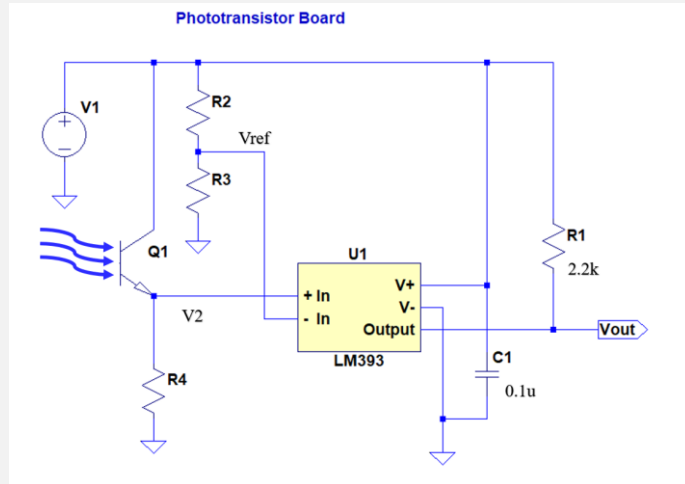

- The design goal of the PTB was to output active high when the PTB detects a certain light intensity and active low otherwise.
 - Active High: the voltage of V1
 - Active Low: voltage near zero
- The comparator converts an analog light intensity sensor to a digital light intensity sensor.
- R2 and R3 simply form a voltage divider that creates a fixed reference voltage Vref.
- R4 determines the sensitivity of the PTB to light. A R4 larger resistance value equates to greater PTB sensitivity.
- When V2 is greater than Vref the PTB outputs active high. To the contrary, when V2 is less than Vref the PTB outputs active low.

DPO SIMULATION AND BANDWIDTH

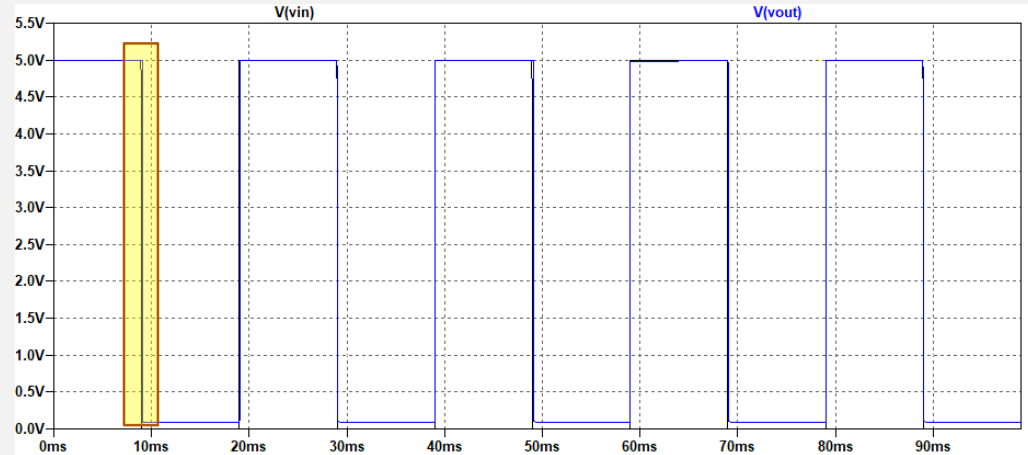
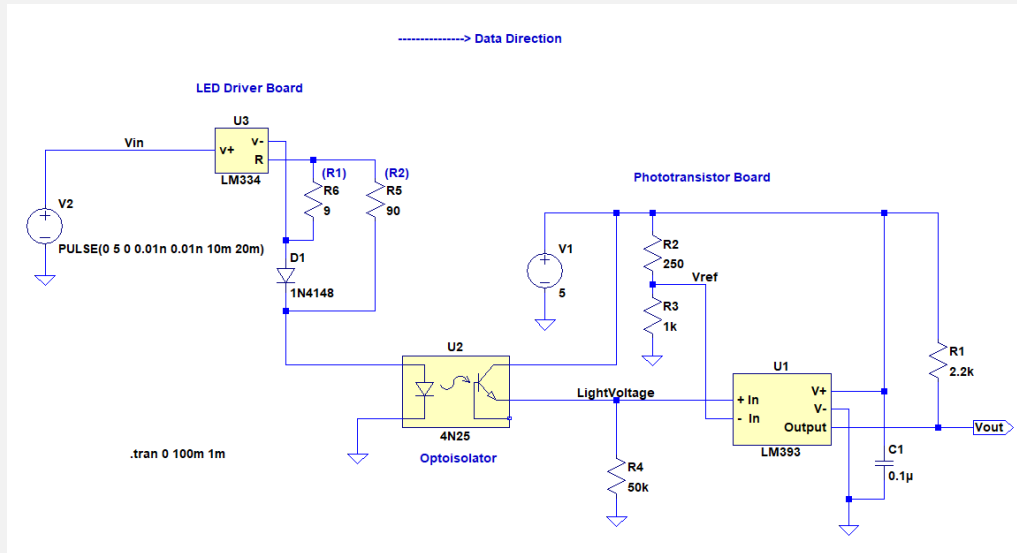

Coupling the LED Driver and the PTB together gives you the complete DPO.

- Upon simulation, the DPO appears to operate as intended. The signal successfully is preserved from the input to the output of the DPO.
- Decaying *lightvoltage* is due to delays in the LED Driver (mostly the LM334 IC and slightly the LED)
- What happens at greater frequencies?

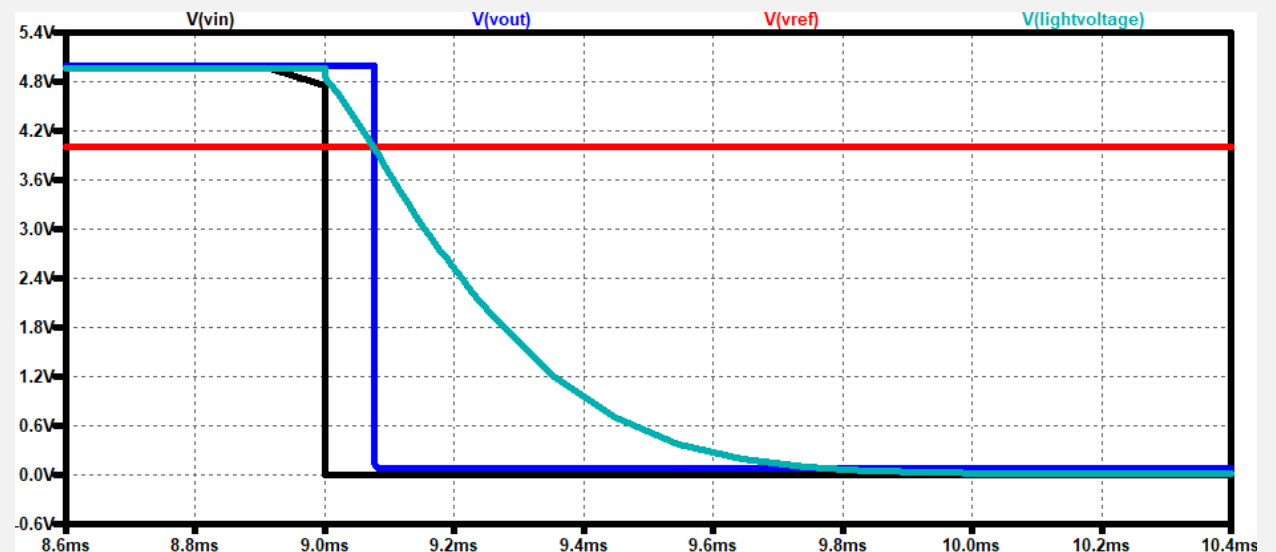

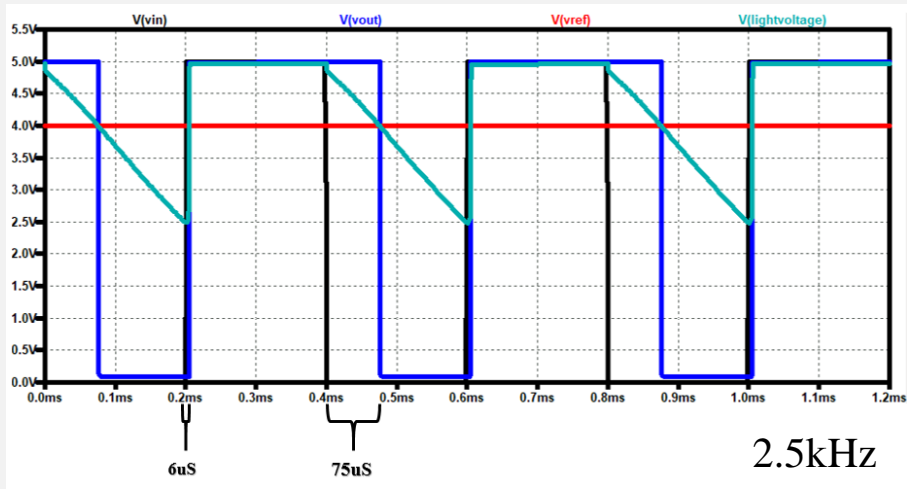

- There difference in delays causes what is referred to pulse width distortion.
- This pulse width distortion will determine the bandwidth of the optoisolator itself.
- The 6µS delay of the rising edges is in part due to the junction capacitance of the of the phototransistor.
 - This delay could be decreased by reducing the load resistance of the phototransistor. However, by decreasing this resistance, the photodetector sensitivity decreases due to the fact that a phototransistor is a light-controlled current source.

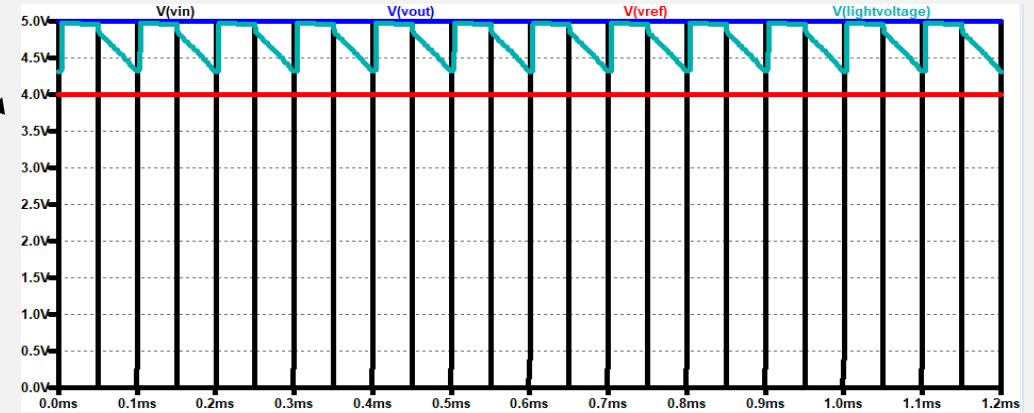
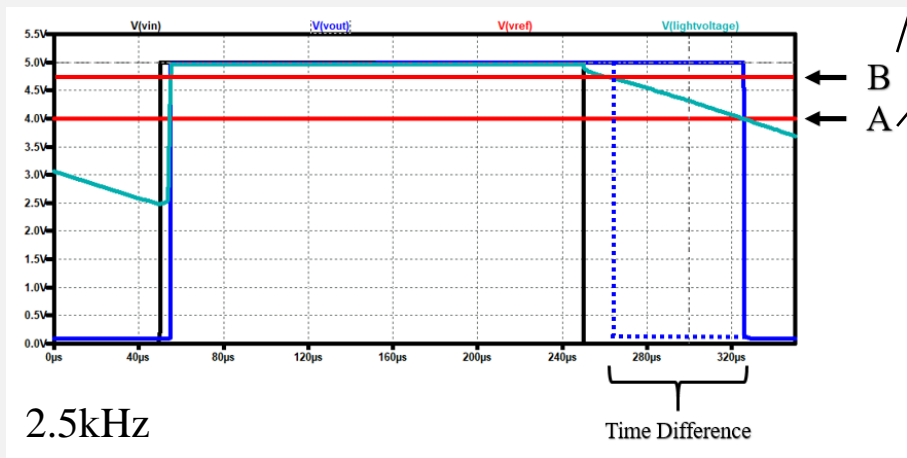

10kHz

- If the signal frequency is too great the signal does not successfully pass through DPO as illustrated with 10kHz simulation.

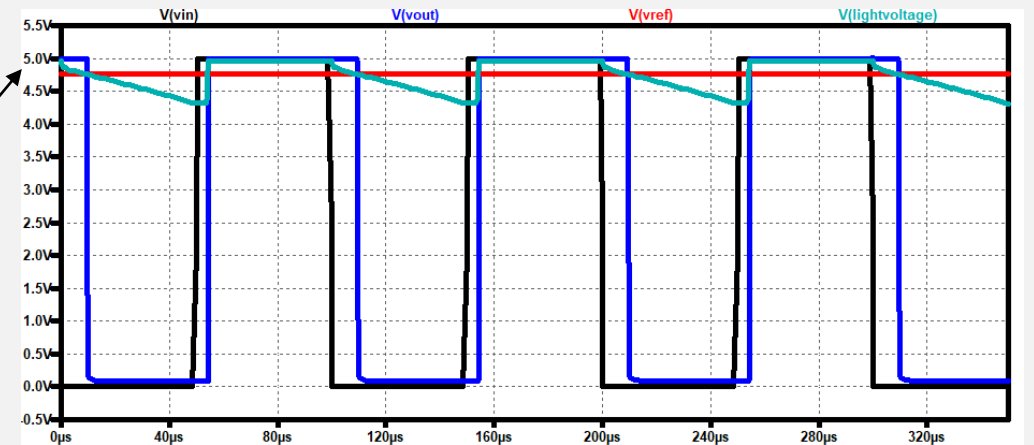

10kHz

- The DPO can operate at a greater frequency if the reference voltage is optimized.
- Minimizing pulse width distortion allows the DPO to operate at greater frequencies.

THE LED AND PHOTOTRANISTOR

- Initially, we used LEDs the emitted light within the visible spectrum.
- Upon choosing a Silicon NPN phototransistor we decided to choose a Gallium Aluminum Arsenide LED that predominantly emitted light with a 880nm wavelength (infrared).

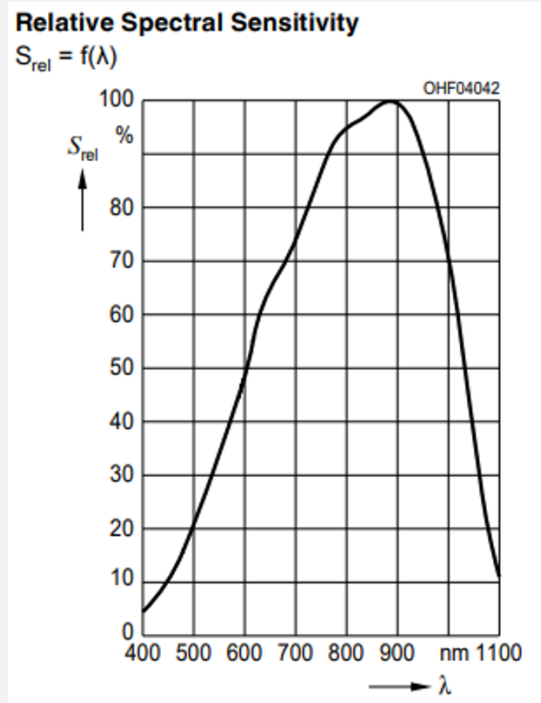

RELATIVE INTENSITY vs. WAVELENGTH

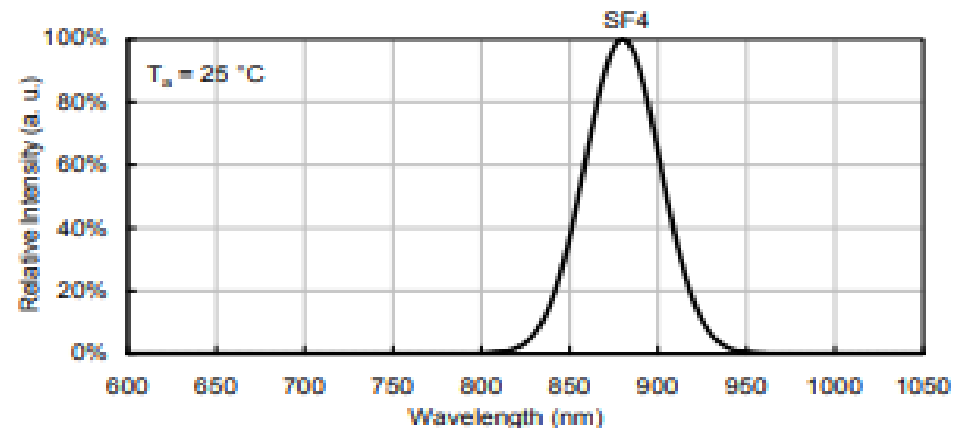

DPO OPTIMIZATION

Resistance	Effect
R2 & R3	Determines the Reference Voltage of the Comparator
R4	Determines the Sensitivity of the Photodetector
R5 & R6	Determines the Light Signal Intensity

- Resistances R2, R3, R4, R5, and R6 determine three variables:
 - Reference Voltage of the Comparator
 - Sensitivity of the Photodetector
 - Light Signal Intensity
- If these three variables, if not properly set, will cause the DPO to be non-functioning.
- These variables can be set such the DPO is optimized for a specific purpose.
- Additionally, these three variables effect the DPOs:
 - Bandwidth
 - Minimum Input Voltage & Maximum Specified Output Voltage
 - Sensitivity
 - Distance of Optical Channel (Transmission Distance)

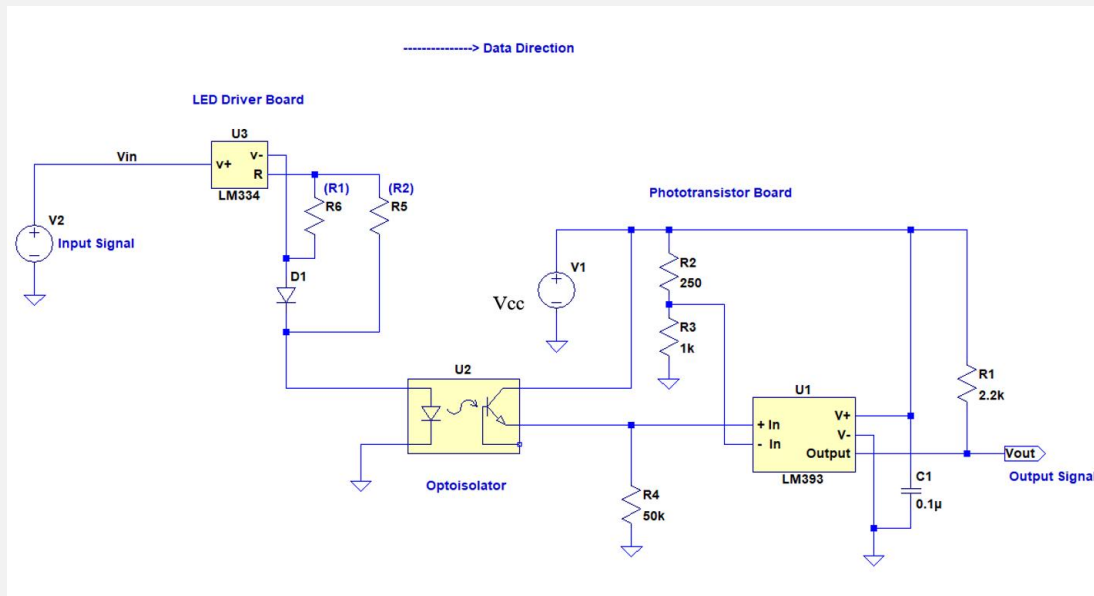

DPO LEVEL SHIFTING

DPO Level Shifting		
	Min	Max
Input Voltage	~3.5	30
Specified Output Voltage	2	~10

- The DPO is capable of shifting voltage levels.
- The minimum input voltage and maximum specified output voltage are dependent upon resistance values R2 – R6.

PROTOTYPES

1

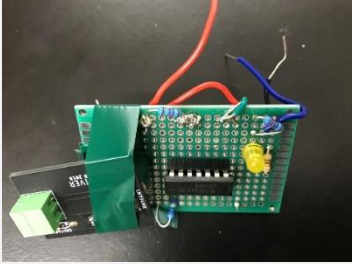

2

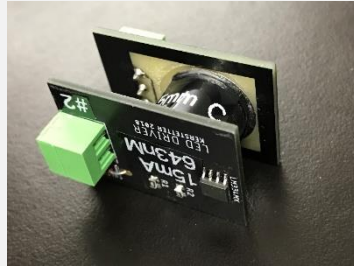
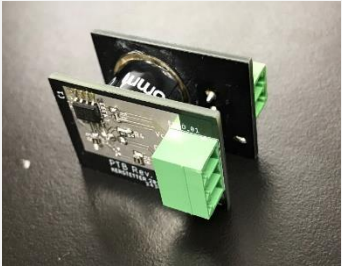

3

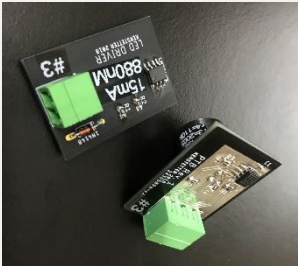

4



- Four prototypes were created to arrive to where the DPO is today.
- Prototype #1 gave us confidence that everything worked as intended.
- Prototype #2 was the first DPO that used both the LED Driver and PTB PCBs.
- Prototype #3 was the first prototype to use an infrared LED.
- All DPOs since, have been largely based upon prototype #4.
- Initially, it was envisioned that a copper tube be soldered to connect the two boards. Instead, a connector tube was 3D printed.
- We arrived to a design that has an array of applications. Three derivative projects have been developed to demonstrate such applications.

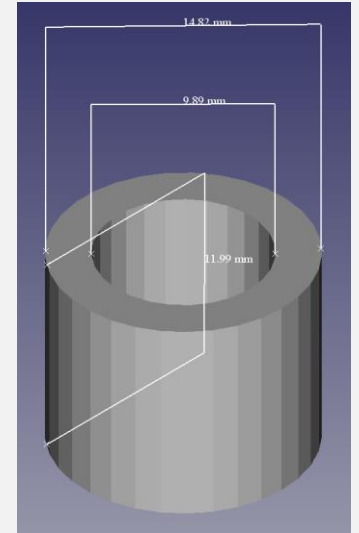

APPLICATION 1: SMART SWITCH

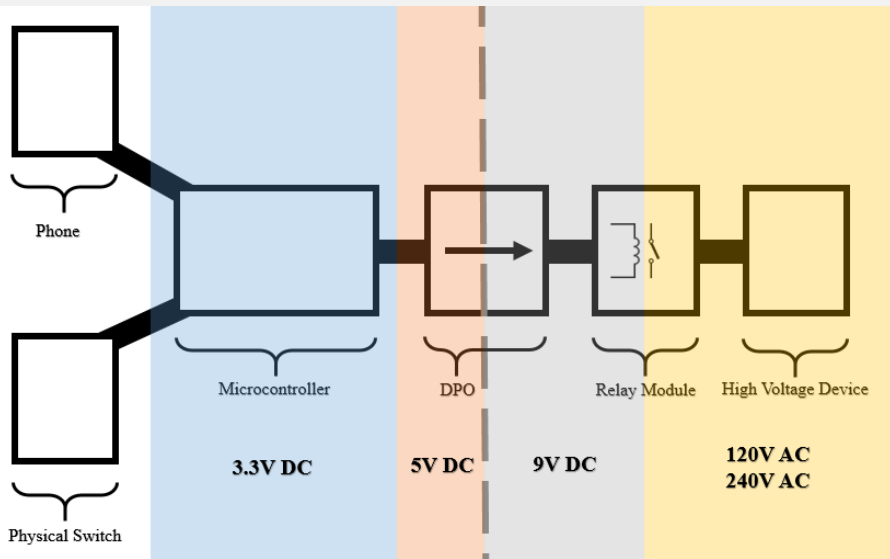

- A common use of an optoisolator is to electrically isolate high voltage and low voltage systems. To demonstrate this application we have created a Smart Switch.
- If any event the relay module malfunctions, the microcontroller would be safe due to complete electrical isolation between the relay module and the microcontroller provided by the DPO.
- The smart switch also uses the DPOs level shifting capability.
 - Shifting 5V DC to 9V DC
- The Smart Switch can be controlled by two methods:
 - Physical Switch
 - Smart Phone via the Blynk application
- The Smart Phone can configure a timer such that the high voltage device can turn on and off automatically.

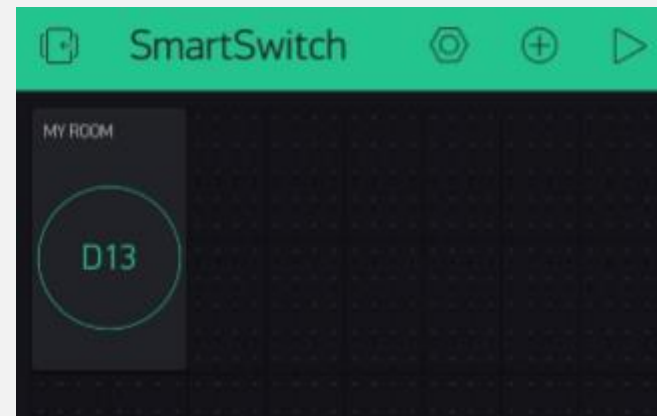
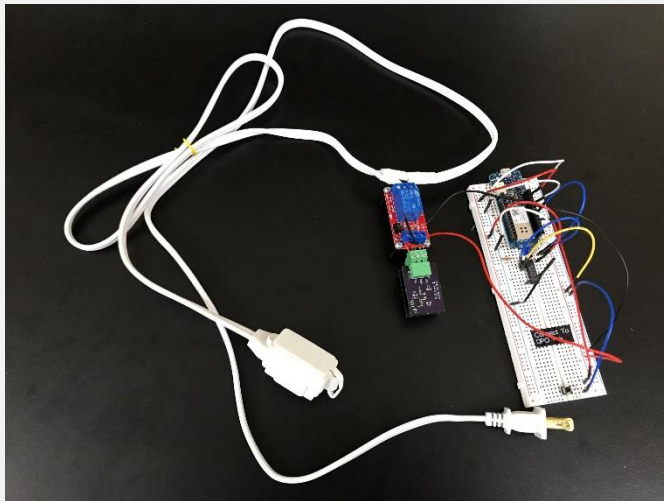

APPLICATION 2: BIDIRECTIONAL OPTICAL LINK (BOL)

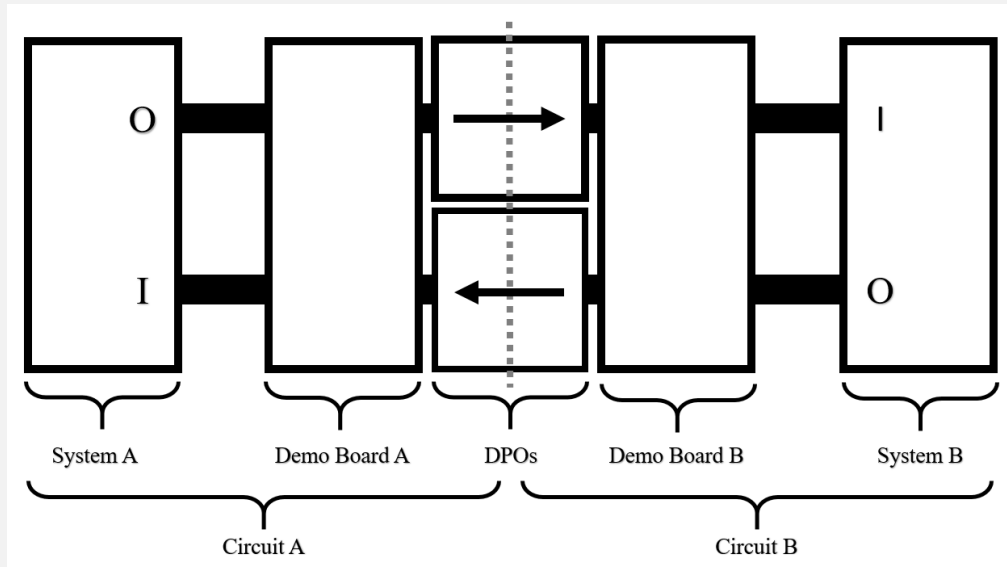

- The Bidirectional Optical Link (BOL) allows for two systems to send digital signals to each other with complete electrical isolation.
- Two separate DPOs allow for bidirectional communication.
- The BOL consists of 6 PCBs and requires two of the following:
 - Demo Board
 - LED Driver
 - PTB

APPLICATION 2: BIDIRECTIONAL OPTICAL LINK (BOL)

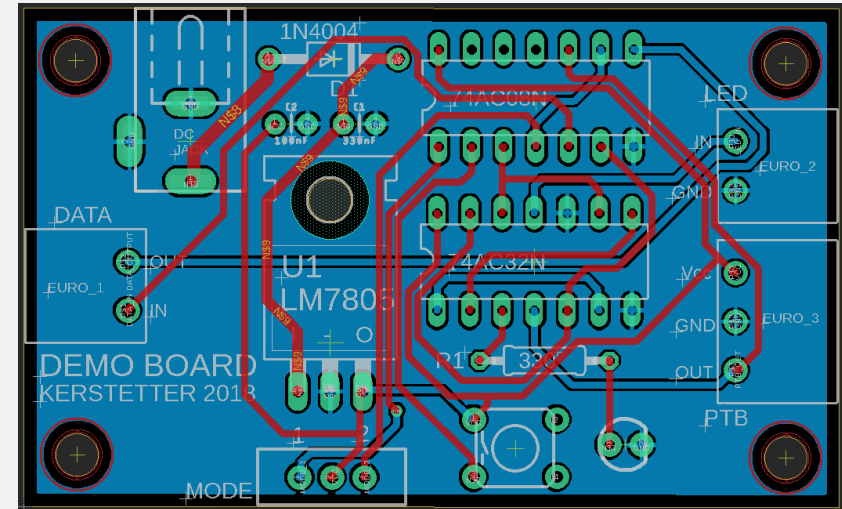
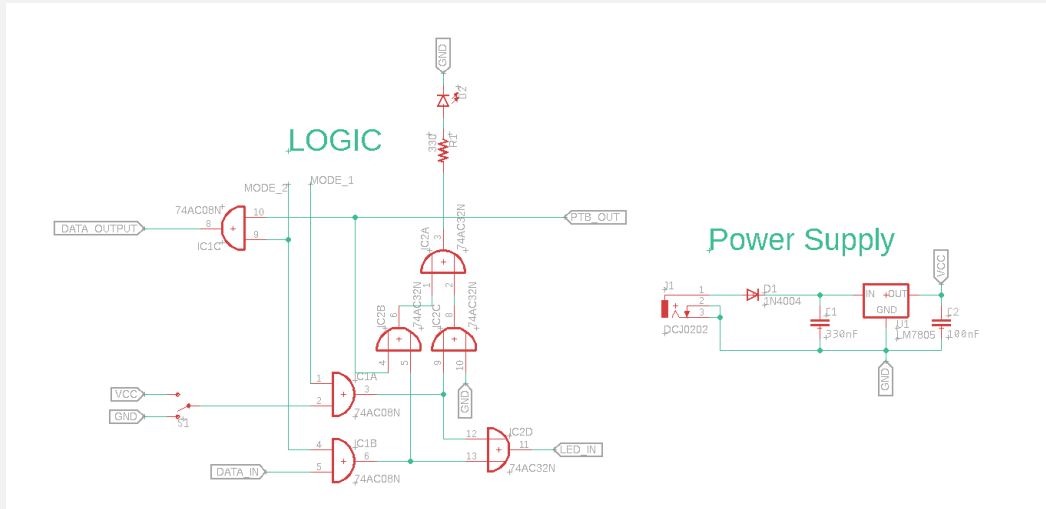

- The Demo Boards each power one LED Driver and one Phototransistor Board.
- A 9-12V DC center-positive barrel jack provides power to the board.

MODE	USE
1	Simple demonstration of the function of the BOL
2	Bi-directional communication of two external systems

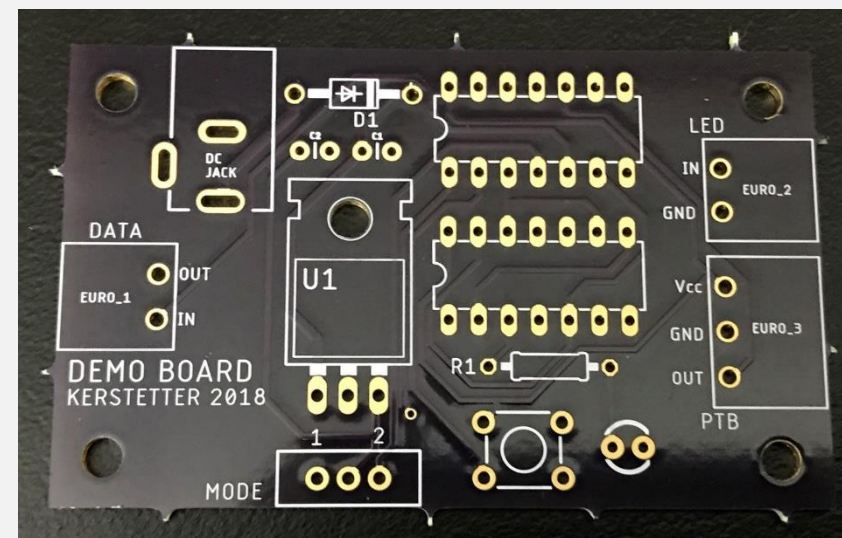

APPLICATION 3: DATA TRANSFER SYSTEM (DTS)

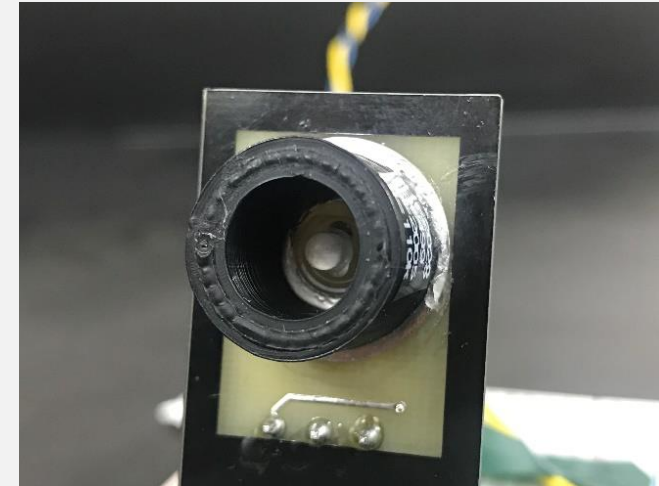
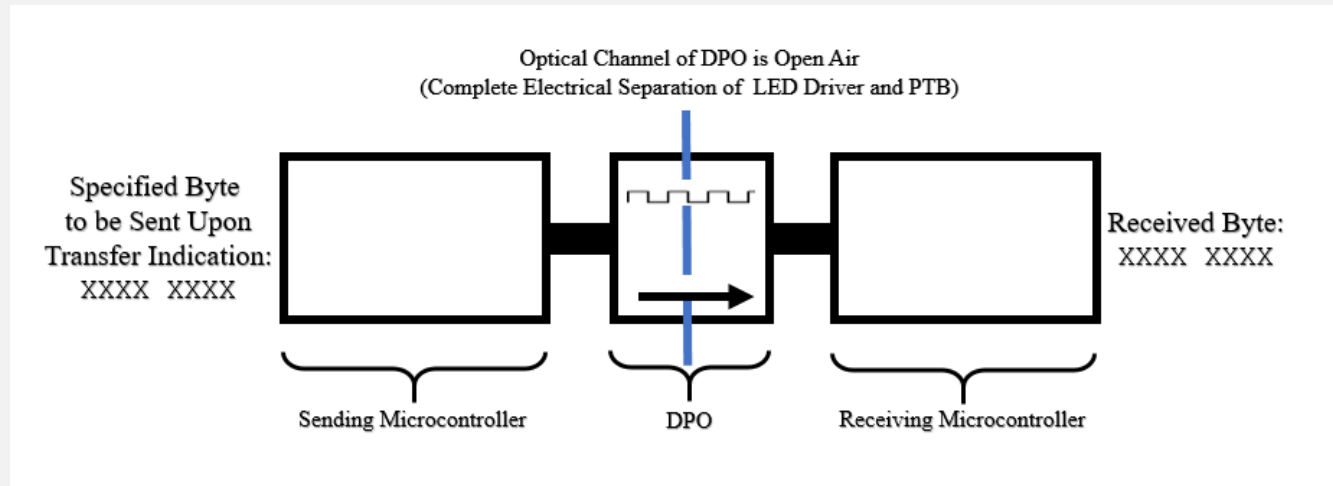

- We have created a Data Transfer System (DTS) to demonstrate that DPOs can transfer information successfully.
- The DPO was designed to have a closed 13mm optical channel. Long distance free space optical communication was not the goal of this project.
- Generally, boards can be separated by 64mm; while, allowing successful data transfer.
- The transmission distance is dependent upon proper alignment of boards and light interference.
- A connector tube is attached to the PTB to shield the phototransistor from optical interference.

APPLICATION 3: DATA TRANSFER SYSTEM

Sending

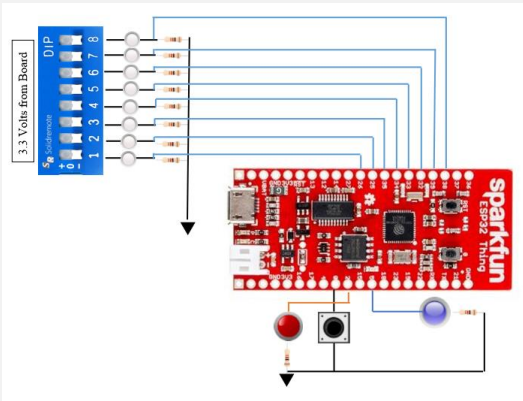

SENDING END

- A byte is specified by a parallel input determined by a 8-pin dip-switch. The transfer button will then begin the data transfer across the optical channel.
- Before any data is sent, a leading signal is sent, to prime the receiving microcontroller. The serial signal sent is at 33.33 Hz.

RECEIVING END

- The receiving microcontroller is polling for a signal every 5 ms.
- The received signal is then displayed as a parallel output.

Receiving

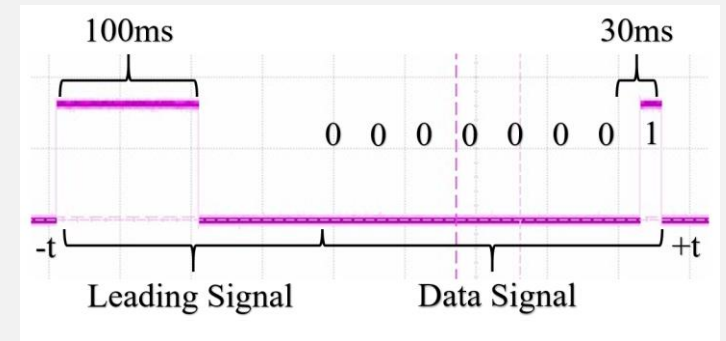
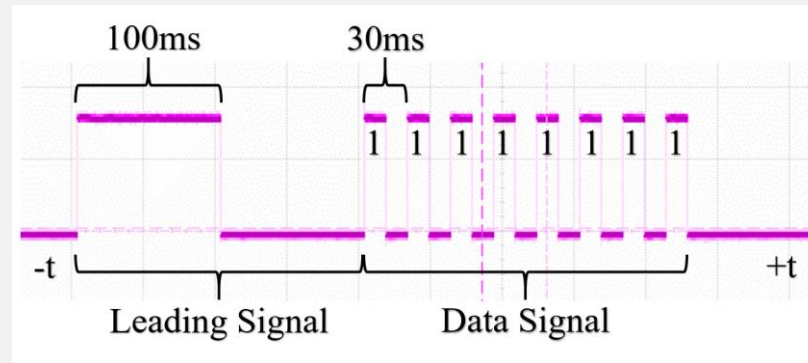
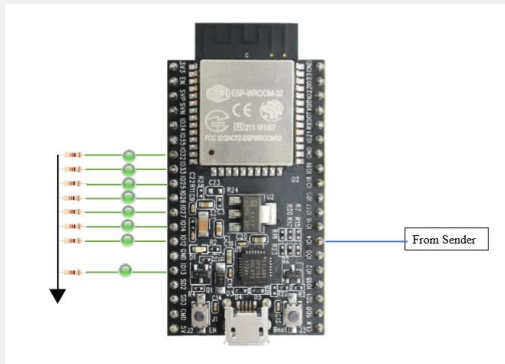

APPLICATION 3: DATA TRANSFER SYSTEM

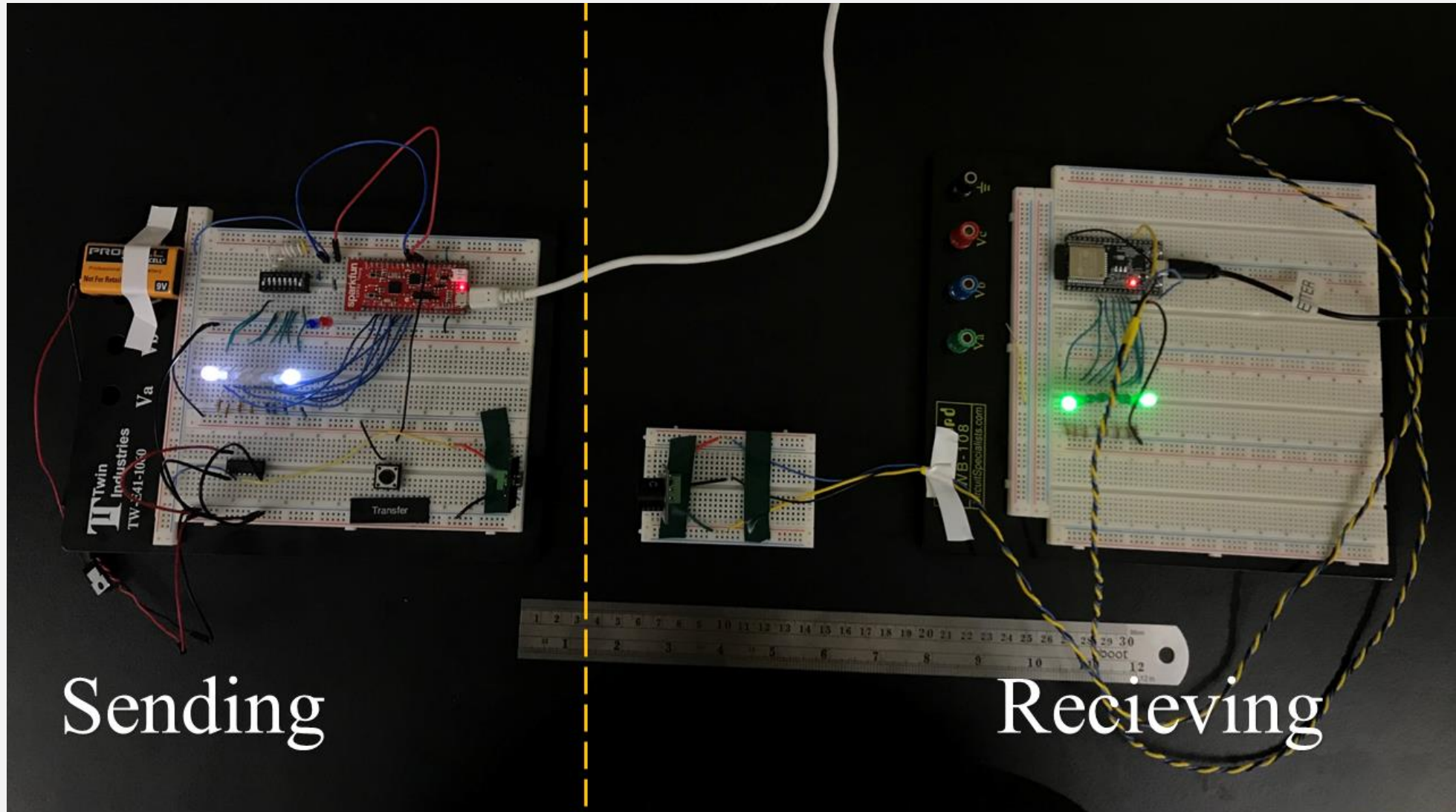

Sending

Receiving

FUTURE WORK AND CONCLUSIONS

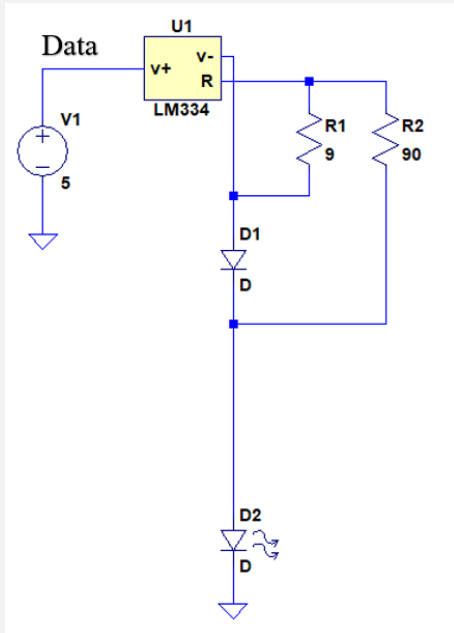

Current
LED Driver

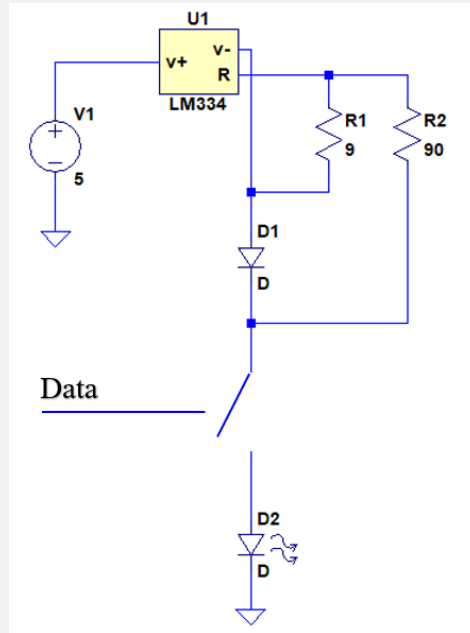

Modified
LED Driver

- We believe that the main bandwidth bottle neck is the LM334s relation to our current circuit.
- The LM334 was not designed to be powered on and off at rapid rates.
- In the future, a switching circuit could be implemented such that DPO could operate at greater frequencies.
- Additionally, we would like to take what we have learned during this project and create a long distance free-space optical communication system. Perhaps, this goal could be achievable using lasers and/or parabolic reflectors.
- Overall, this project allowed us to gain a fantastic introduction into the world of optoelectronics.

QUESTIONS?

Our **project report** will be available at our desk if anyone is interested in further details regarding our project or the code that we used.