

Show your work for credit and put a box around each of your answers (follow the hw guidelines!)

- Using AC analysis determine the output voltage and power dissipated by the resistor in each of the circuits seen below. Plot the output voltage along with the input current or voltage to show the phase shift. Verify your answers using LTspice. (2 points each)

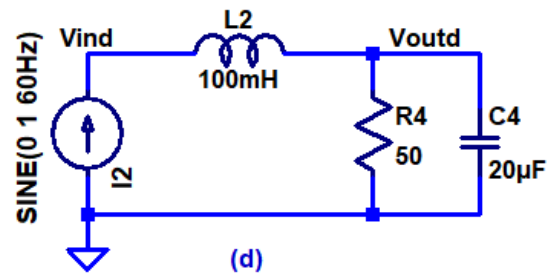
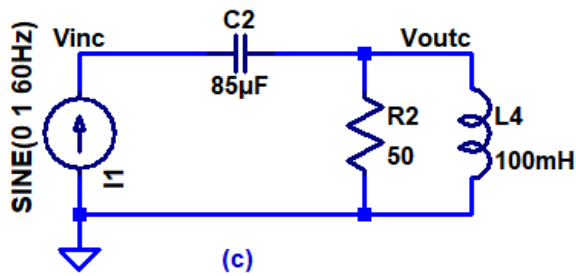
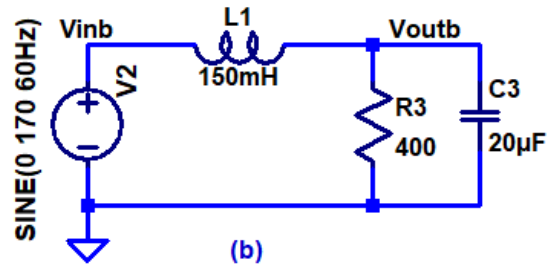
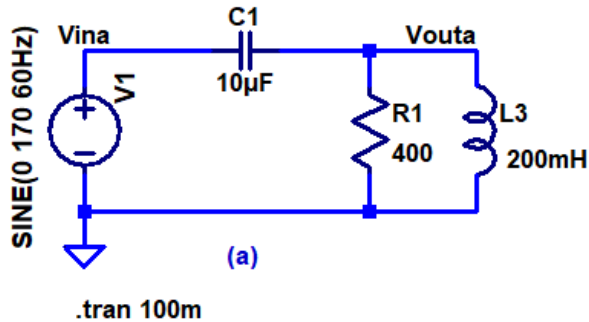

- Determine the frequency response (V_{out}/V_{in} , both magnitude and phase) of the circuits in problem 1. Verify your hand calculations and plots using LTspice. (1 point each)