



US009135962B2

(12) **United States Patent**
Baker

(10) **Patent No.:** **US 9,135,962 B2**
(45) **Date of Patent:** **Sep. 15, 2015**

(54) **COMPARATORS FOR DELTA-SIGMA MODULATORS**

(75) Inventor: **R. Jacob Baker**, Boise, ID (US)

(73) Assignee: **Micron Technology, Inc.**, Boise, ID (US)

(*) Notice: Subject to any disclaimer, the term of this patent is extended or adjusted under 35 U.S.C. 154(b) by 925 days.

(21) Appl. No.: **11/818,996**

(22) Filed: **Jun. 15, 2007**

(65) **Prior Publication Data**
US 2008/0309533 A1 Dec. 18, 2008

(51) **Int. Cl.**
H03M 3/00 (2006.01)
G11C 7/02 (2006.01)
G11C 7/04 (2006.01)
G11C 7/16 (2006.01)
G11C 8/08 (2006.01)
G11C 8/10 (2006.01)
G11C 11/56 (2006.01)
G11C 13/00 (2006.01)
G11C 27/00 (2006.01)
H04N 5/378 (2011.01)
G11C 7/06 (2006.01)

(52) **U.S. Cl.**
CPC .. **G11C 7/02** (2013.01); **G11C 7/04** (2013.01);
G11C 7/16 (2013.01); **G11C 8/08** (2013.01);
G11C 8/10 (2013.01); **G11C 11/5642**
(2013.01); **G11C 11/5678** (2013.01); **G11C 13/0004** (2013.01); **G11C 13/004** (2013.01);
G11C 13/0028 (2013.01); **G11C 27/005**
(2013.01); **H03M 3/39** (2013.01); **H04N 5/378**
(2013.01); **G11C 7/06** (2013.01); **G11C 2013/0054** (2013.01); **G11C 2211/5645**
(2013.01); **H03M 3/43** (2013.01); **H03M 3/456**
(2013.01)

(58) **Field of Classification Search**

CPC H03M 3/39; H03M 3/43; G11C 7/02
USPC 341/50, 144, 155, 143
See application file for complete search history.

(56) **References Cited**

U.S. PATENT DOCUMENTS

5,065,157	A *	11/1991	Ribner et al.	341/143
5,465,093	A *	11/1995	Kusumoto et al.	341/122
5,600,319	A	2/1997	Ginetti	
5,614,856	A	3/1997	Wilson et al.	
5,659,316	A *	8/1997	Stierli	341/143
5,801,657	A *	9/1998	Fowler et al.	341/155
5,907,299	A *	5/1999	Green et al.	341/143
5,953,276	A	9/1999	Baker	
5,955,899	A *	9/1999	Afghahi	327/65
6,021,172	A *	2/2000	Fossum et al.	377/60
6,044,019	A	3/2000	Cernea et al.	
6,188,340	B1	2/2001	Matsumoto et al.	
6,215,423	B1 *	4/2001	May et al.	341/61
6,229,133	B1 *	5/2001	Hynecek	250/208.1
6,282,120	B1	8/2001	Cernea et al.	

(Continued)

OTHER PUBLICATIONS

Rane Corporation, RaneNote 137, "Digital Charma of Audio A/D Converters," 1997, 12 pgs.

(Continued)

Primary Examiner — Peguy Jean Pierre

(74) Attorney, Agent, or Firm — Fletcher Yoder, P.C.

(57) **ABSTRACT**

Methods, systems and devices are disclosed, such as an electronic device that includes a plurality of data locations and a delta-sigma modulator. In some embodiments, the delta-sigma modulator includes a preamplifier coupled to the data locations and a latch coupled to the preamplifier.

21 Claims, 21 Drawing Sheets

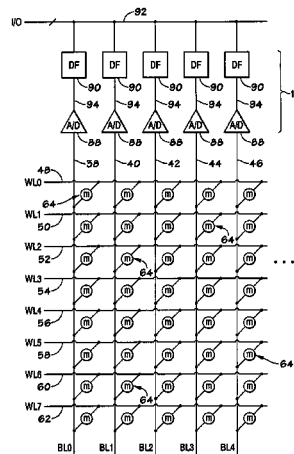

(56)

References Cited

U.S. PATENT DOCUMENTS

- | | | | | |
|--------------|------|---------|-----------------|-----------|
| 6,288,666 | B1 * | 9/2001 | Afghahi et al. | 341/158 |
| 6,348,682 | B1 * | 2/2002 | Lee | 250/214 A |
| 6,490,200 | B2 | 12/2002 | Cernea et al. | |
| 6,504,750 | B1 | 1/2003 | Baker | |
| 6,567,297 | B2 | 5/2003 | Baker | |
| 6,661,708 | B2 | 12/2003 | Cernea et al. | |
| 6,664,708 | B2 | 12/2003 | Shlimak et al. | |
| 6,665,013 | B1 * | 12/2003 | Fossum et al. | 348/308 |
| 6,741,502 | B1 | 5/2004 | Cernea | |
| 6,781,906 | B2 | 8/2004 | Perner et al. | |
| 6,785,156 | B2 | 8/2004 | Baker | |
| 6,795,359 | B1 | 9/2004 | Baker | |
| 6,798,705 | B2 | 9/2004 | Baker | |
| 6,807,403 | B2 | 10/2004 | Tanaka | |
| 6,813,208 | B2 | 11/2004 | Baker | |
| 6,822,892 | B2 | 11/2004 | Baker | |
| 6,826,102 | B2 | 11/2004 | Baker | |
| 6,829,122 | B2 | 12/2004 | Yamada et al. | |
| 6,847,234 | B2 | 1/2005 | Choi | |
| 6,850,441 | B2 | 2/2005 | Mokhlesi et al. | |
| 6,856,564 | B2 | 2/2005 | Baker | |
| 6,870,784 | B2 | 3/2005 | Baker | |
| 6,901,020 | B2 | 5/2005 | Baker | |
| 6,914,838 | B2 | 7/2005 | Baker | |
| 6,930,942 | B2 | 8/2005 | Baker | |
| 6,947,720 | B2 * | 9/2005 | Razavi et al. | 455/333 |
| 6,954,390 | B2 | 10/2005 | Baker | |
| 6,954,391 | B2 | 10/2005 | Baker | |
| 6,963,369 | B1 * | 11/2005 | Olding | 348/241 |
| 6,977,601 | B1 | 12/2005 | Fletcher et al. | |
| 6,985,375 | B2 | 1/2006 | Baker | |
| 7,002,833 | B2 | 2/2006 | Hush et al. | |
| 7,009,901 | B2 | 3/2006 | Baker | |
| 7,095,667 | B2 | 8/2006 | Baker | |
| 7,102,932 | B2 | 9/2006 | Baker | |
| 7,130,235 | B2 * | 10/2006 | Perner | 365/207 |
| 7,133,307 | B2 | 11/2006 | Baker | |
| 7,218,350 | B2 * | 5/2007 | Hyneczek | 348/308 |
| 7,221,498 | B2 * | 5/2007 | Richards et al. | 359/291 |
| 7,362,255 | B1 * | 4/2008 | Tsyrganovich | 341/172 |
| 7,366,021 | B2 | 4/2008 | Taylor et al. | |
| 7,420,497 | B2 * | 9/2008 | Chiu | 341/155 |
| 7,468,688 | B2 * | 12/2008 | Hesener | 341/144 |
| 7,532,137 | B2 * | 5/2009 | Doerrer | 341/143 |
| 2002/0101758 | A1 | 8/2002 | Baker | |
| 2002/0194557 | A1 | 12/2002 | Park | |
| 2003/0039162 | A1 | 2/2003 | Baker | |
| 2003/0043616 | A1 | 3/2003 | Baker | |
| 2003/0067797 | A1 | 4/2003 | Baker | |
| 2003/0198078 | A1 | 10/2003 | Baker | |
| 2003/0214868 | A1 | 11/2003 | Baker | |
| 2004/0008555 | A1 | 1/2004 | Baker | |
| 2004/0032760 | A1 | 2/2004 | Baker | |
| 2004/0062100 | A1 | 4/2004 | Baker | |
| 2004/0076052 | A1 | 4/2004 | Baker | |
| 2004/0095839 | A1 | 5/2004 | Baker | |
| 2004/0190327 | A1 | 9/2004 | Baker | |
| 2004/0190334 | A1 | 9/2004 | Baker | |
| 2004/0199710 | A1 | 10/2004 | Baker | |
| 2004/0240294 | A1 | 12/2004 | Baker | |
| 2005/0002249 | A1 | 1/2005 | Baker | |
| 2005/0007803 | A1 | 1/2005 | Baker | |
| 2005/0007850 | A1 | 1/2005 | Baker | |
| 2005/0013184 | A1 | 1/2005 | Baker | |
| 2005/0018477 | A1 | 1/2005 | Baker | |
| 2005/0018512 | A1 | 1/2005 | Baker | |
| 2005/0041128 | A1 | 2/2005 | Baker | |
| 2005/0088892 | A1 | 4/2005 | Baker | |
| 2005/0088893 | A1 | 4/2005 | Baker | |
| 2005/0201145 | A1 | 9/2005 | Baker | |
| 2006/0013040 | A1 | 1/2006 | Baker | |
| 2006/0053247 | A1 * | 3/2006 | Cheung et al. | 711/103 |
| 2006/0062062 | A1 | 3/2006 | Baker | |
| 2006/0082486 | A1 * | 4/2006 | Oprescu | 341/155 |
| 2006/0221696 | A1 | 10/2006 | Li | |
| 2006/0227641 | A1 | 10/2006 | Baker | |
| 2006/0250853 | A1 | 11/2006 | Taylor et al. | |
| 2006/0291291 | A1 | 12/2006 | Hosono et al. | |
| 2008/0309530 | A1 | 12/2008 | Baker | |

OTHER PUBLICATIONS

- Baker, R.J., (2001-2006) *Sensing Circuits for Resistive Memory*, presented at various universities and companies.
- Baker, "CMOS Mixed Signal Circuit Design," IEEE Press, A. John Wiley & Sons, Inc.; Copyright 2003, Figures 30.63, 31.82, 32.6, 32.7, 32.24, 32.51, 33.34, 33.47, 33.51, 34.18, 34.24; located at <http://cmosedu.com/cmos2/book2.htm>.
- Dallas Semiconductor, Maxim Application Note 1870, "Demystifying Sigma-Delta ADCs," (Jan. 31, 2003), 15 pgs.
- Baker, R.J., (2003) *Mixed-Signal Design in the Microelectronics Curriculum*, IEEE University/Government/Industry Microelectronics (UGIM) Symposium, Jun. 30-Jul. 2, 2003.
- Baker, R.J. (2004) *Delta-Sigma Modulation for Sensing, IEEE/EDS Workshop on Microelectronics and Electron Devices (WMED)*, Apr. 2004.
- Baker, "CMOS Circuit Design, Layout, and Simulation," Second Edition, IEEE Press, A. John Wiley & Sons, Inc.; Copyright 2005; Chapters 13, 16, 17, 20, 22-24, 28-29; pp. 375-396, 433-522, 613-656, 711-828, 931-1022.
- Hadrick, M. and Baker, R.J., (2005) *Sensing in CMOS Imagers using Delta-Sigma Modulation*, a general presentation of our work in this area.
- Baker, R.J. (2005) Design of High-Speed CMOS Op-Amps for Signal Processing, *IEEE/EDS Workshop on Microelectronics and Electron Devices (WMED)*, Apr. 2005.
- Leslie, M.B., and Baker, R.J., (2006) "Noise-Shaping Sense Amplifier for MRAM Cross-Point Arrays," *IEEE Journal of Solid State Circuits*, vol. 41, No. 3, pp. 699-704.
- Duvvada, K., Saxena, V., and Baker, R. J., (2006) *High Speed Digital Input Buffer Circuits*, proceedings of the IEEE/EDS Workshop on Microelectronics and Electron Devices (WMED), pp. 11-12, Apr. 2006.
- Saxena, V., Plum, T.J., Jessing, J.R., and Baker, R. J., (2006) *Design and Fabrication of a MEMS Capacitive Chemical Sensor System*, proceedings of the IEEE/EDS Workshop on Microelectronics and Electron Devices (WMED), pp. 17-18, Apr. 2006.
- Baker, R.J. and Saxena, V., (2007) *Design of Bandpass Delta Sigma Modulators: Avoiding Common Mistakes*, presented at various universities and companies.
- Wikipedia—definition of "Error detection and correction", pulled from website Jun. 1, 2007, 9 pgs.
- Wikipedia—definition of "Hamming code", pulled from website Jun. 1, 2007, 8 pgs.
- Wikipedia—definition of "Linear feedback shift register (LFSR)", pulled from website Jun. 1, 2007, 4 pgs.
- Park, "Motorola Digital Signal Processors—Principles of Sigma-Delta Modulation for Analog-to-Digital Converters," (Undated).

* cited by examiner

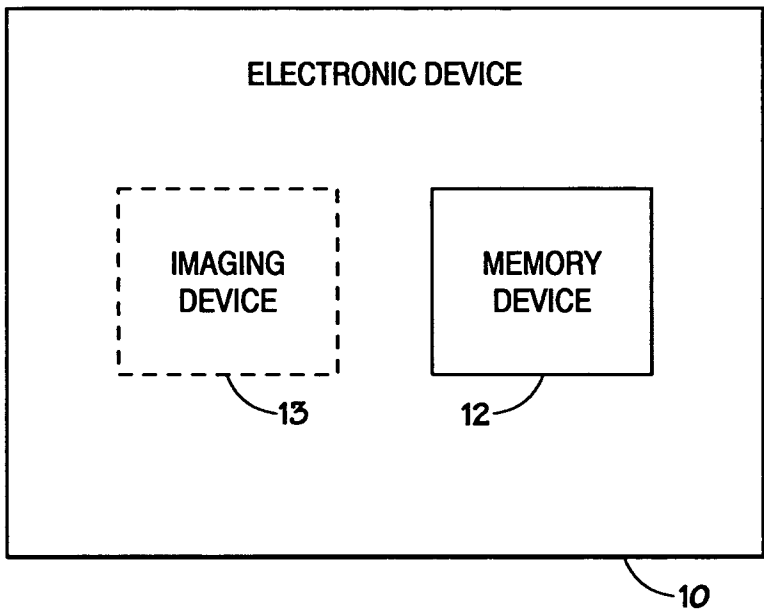

FIG. 1

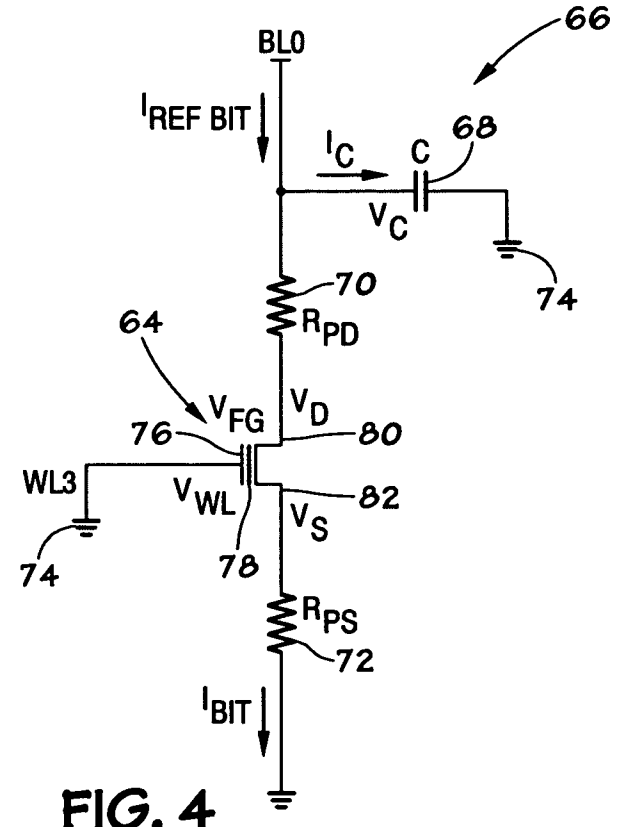

FIG. 4

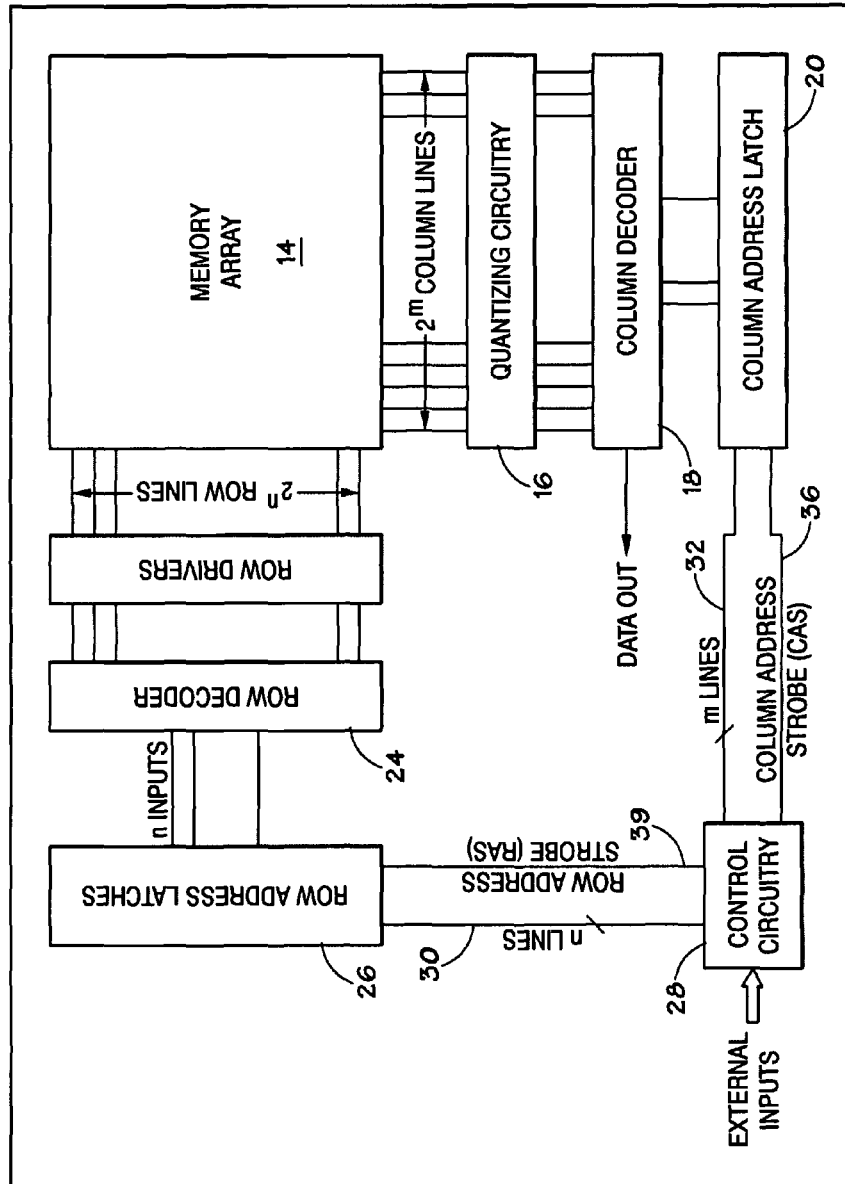

FIG. 2

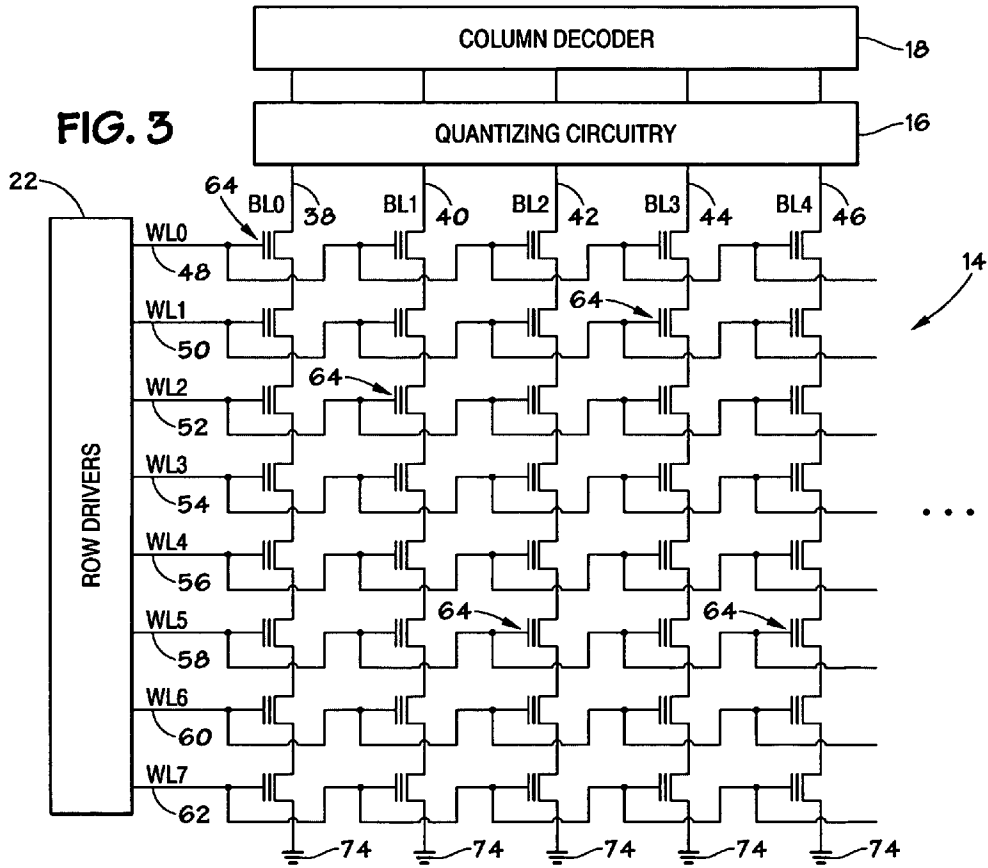

FIG. 5

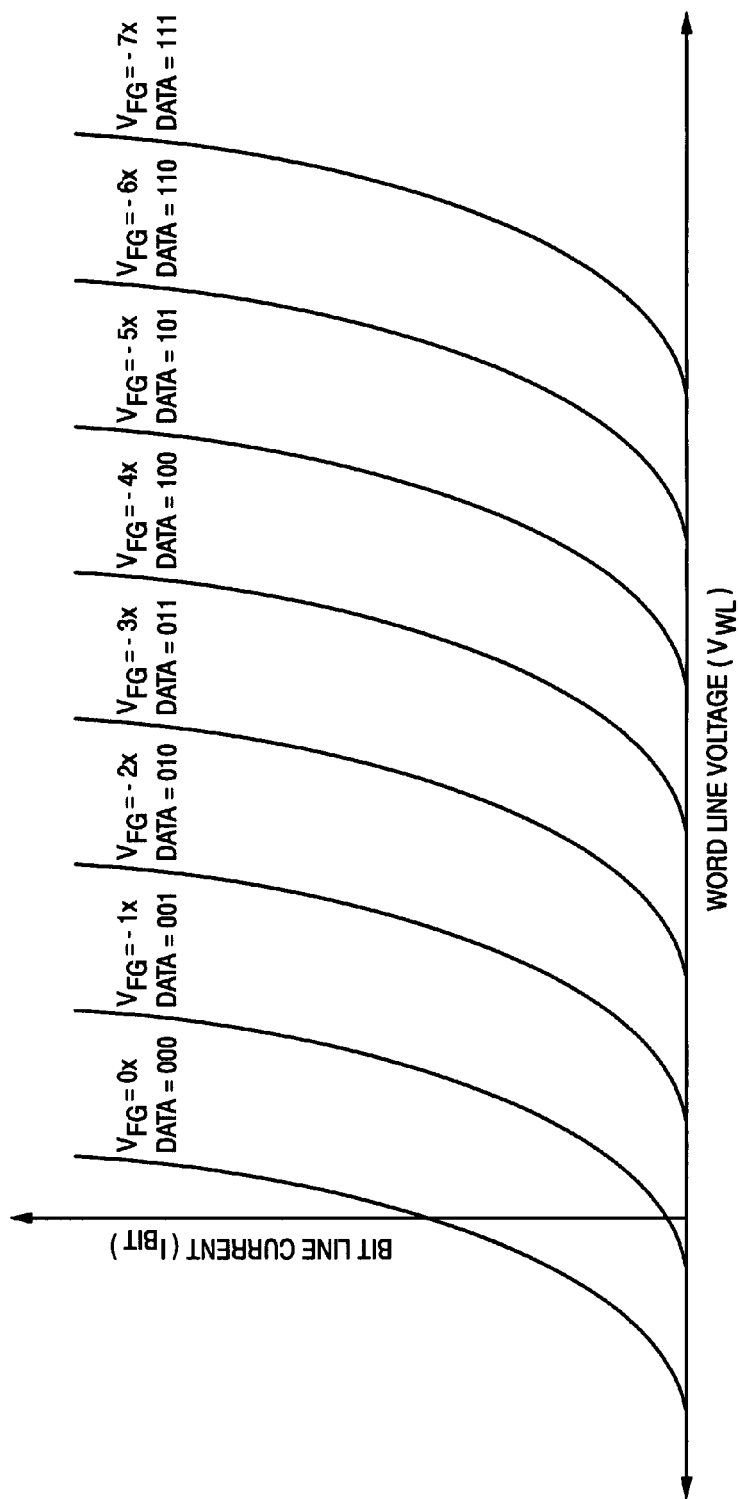
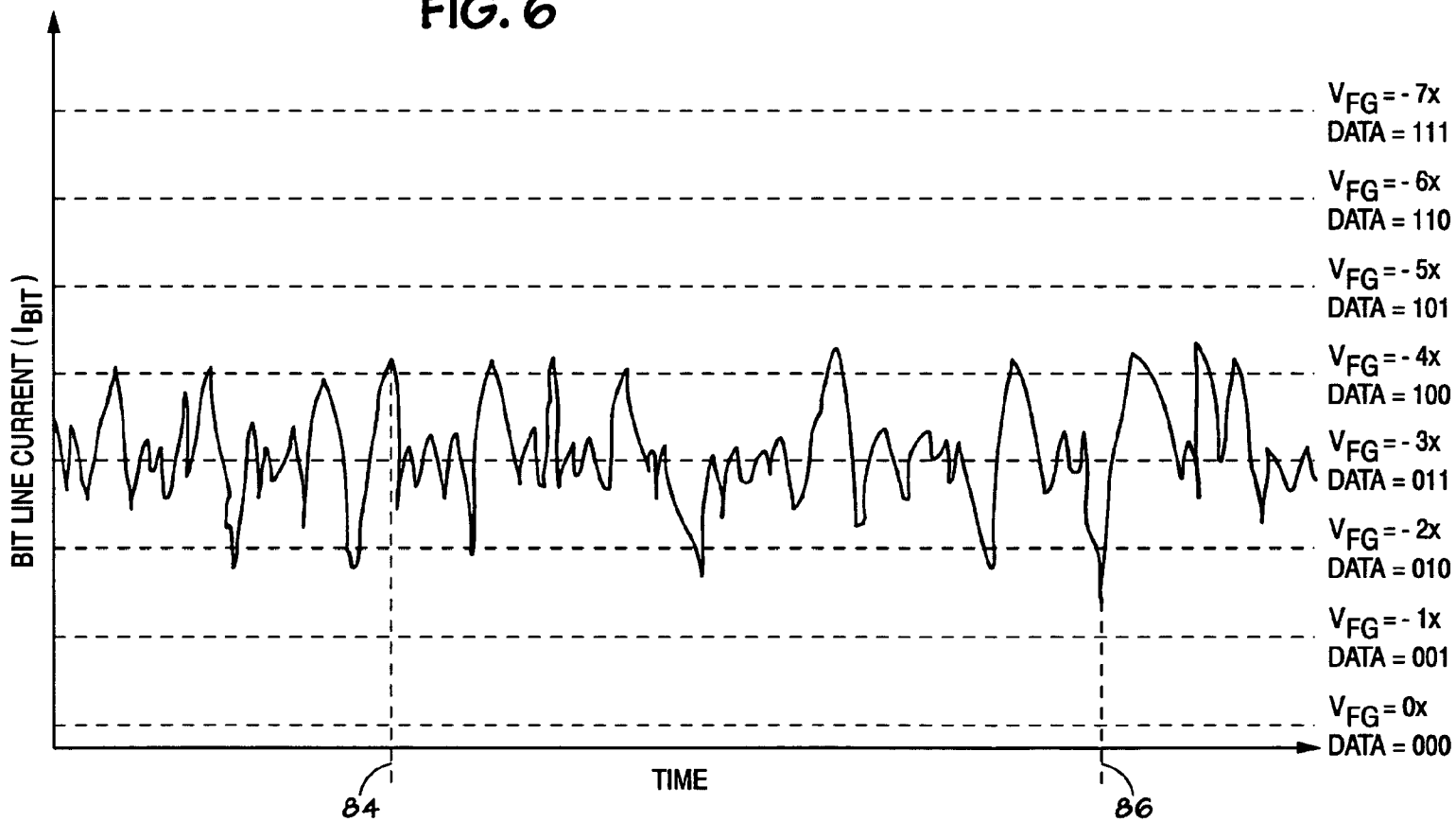

FIG. 6



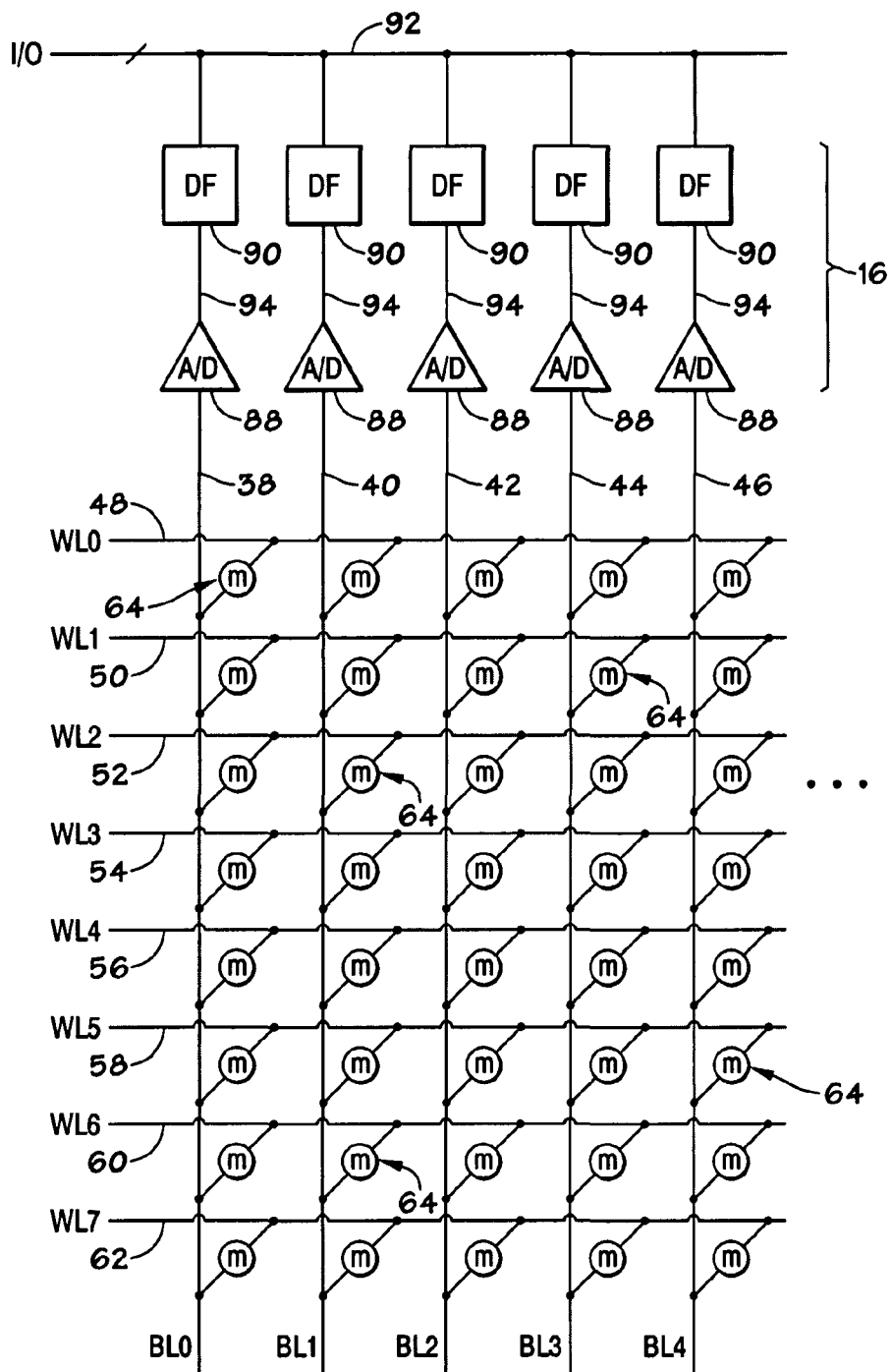

FIG. 7

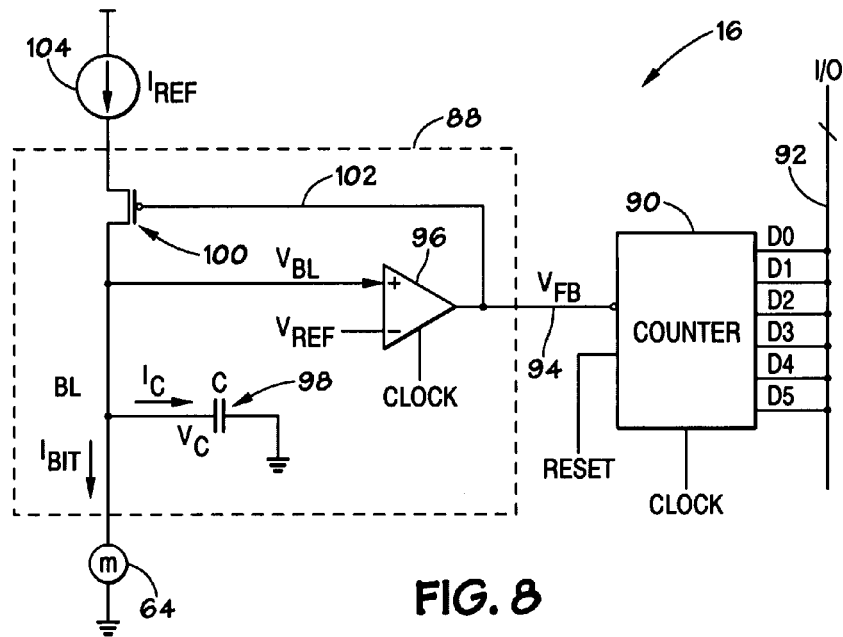

FIG. 8

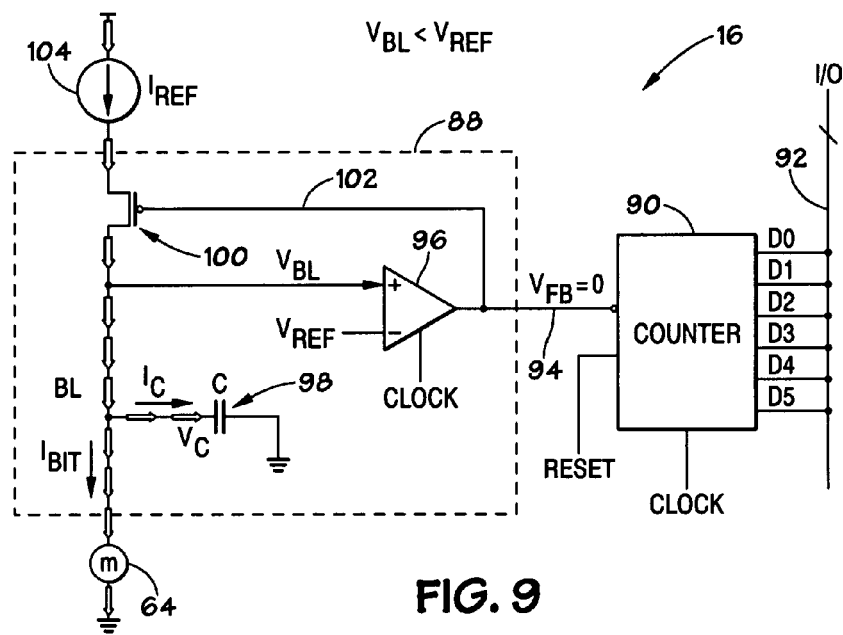

FIG. 9

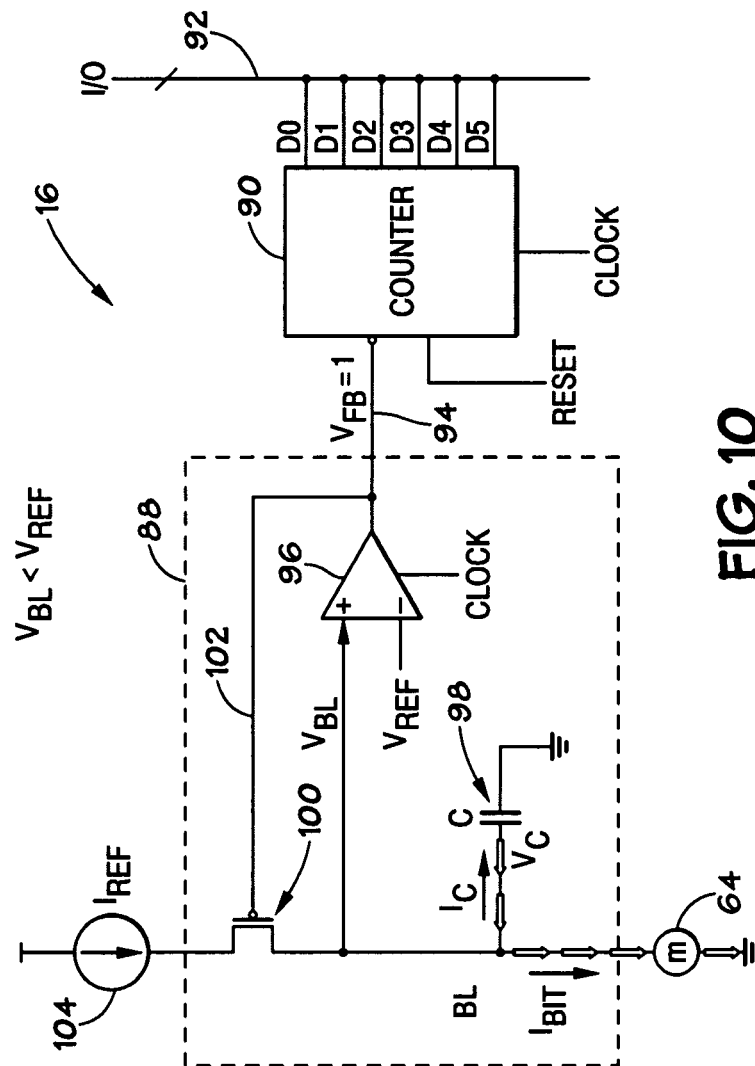
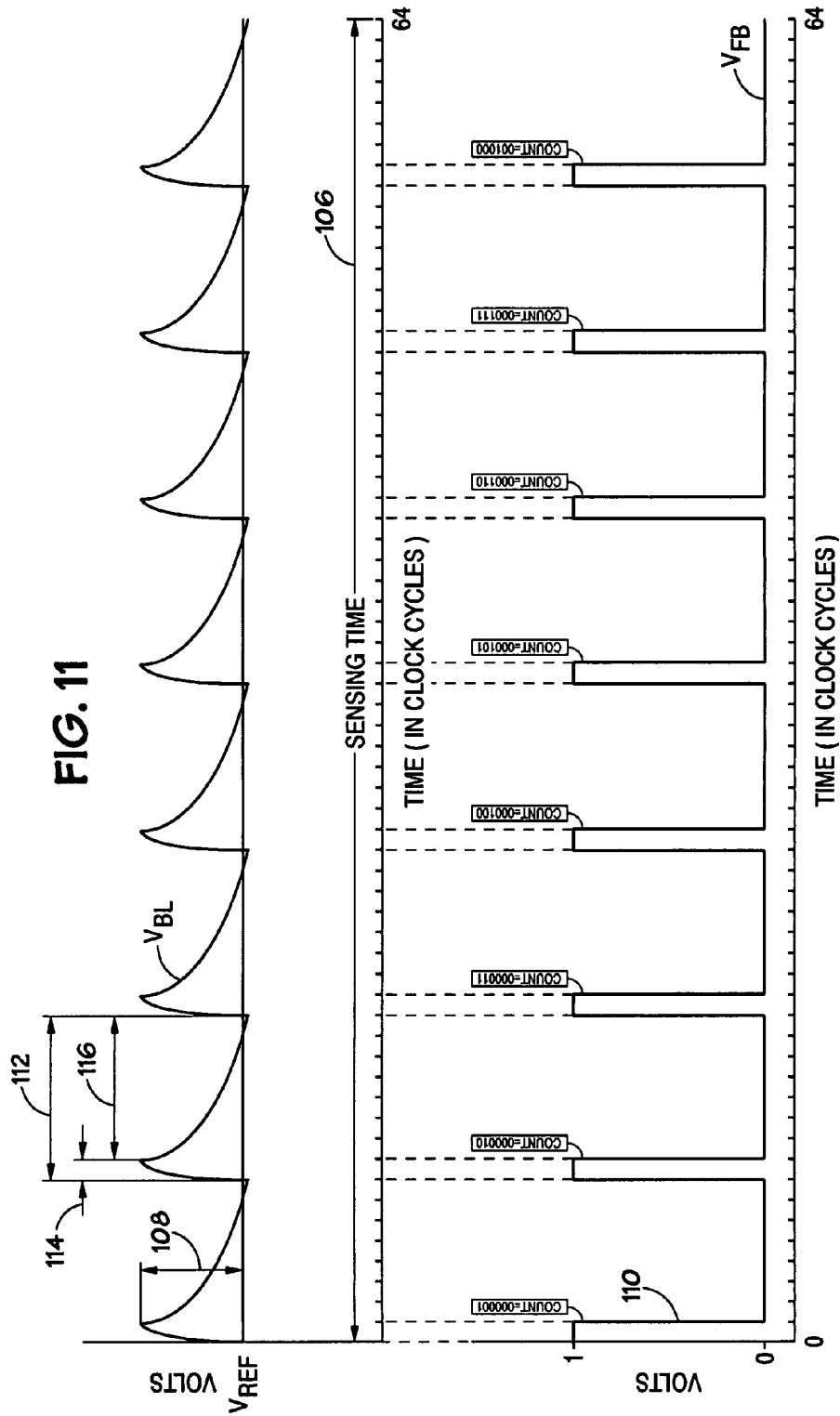
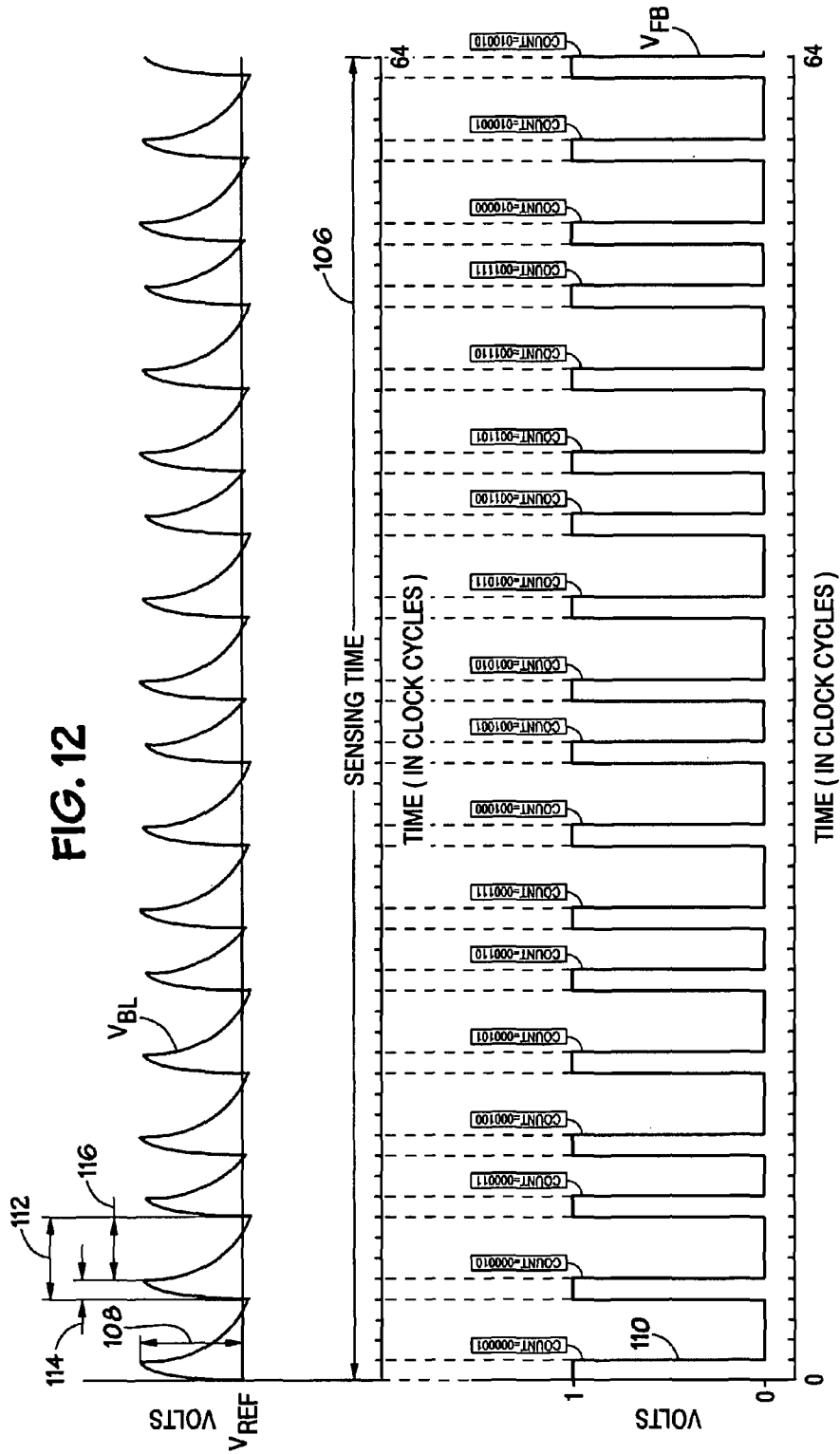

FIG. 10





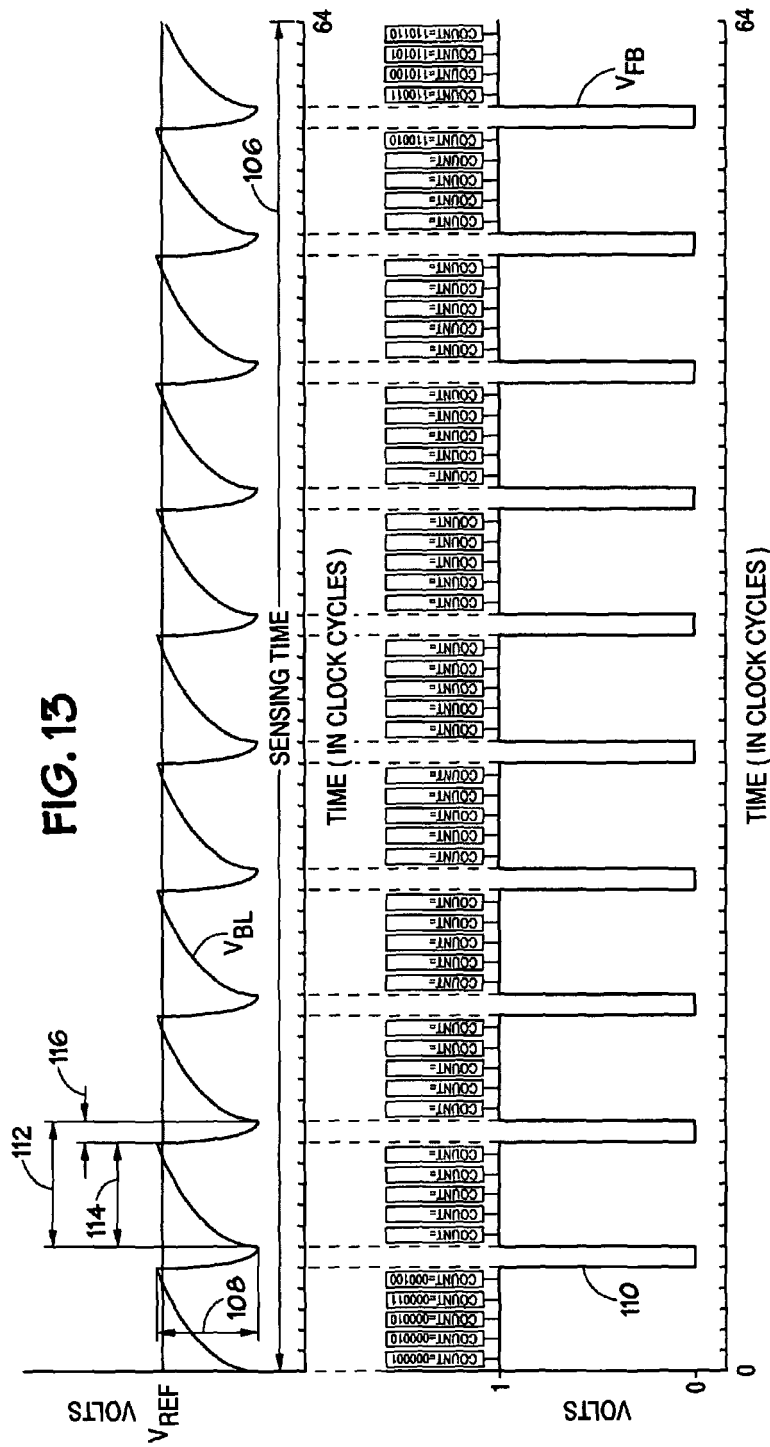

FIG. 14

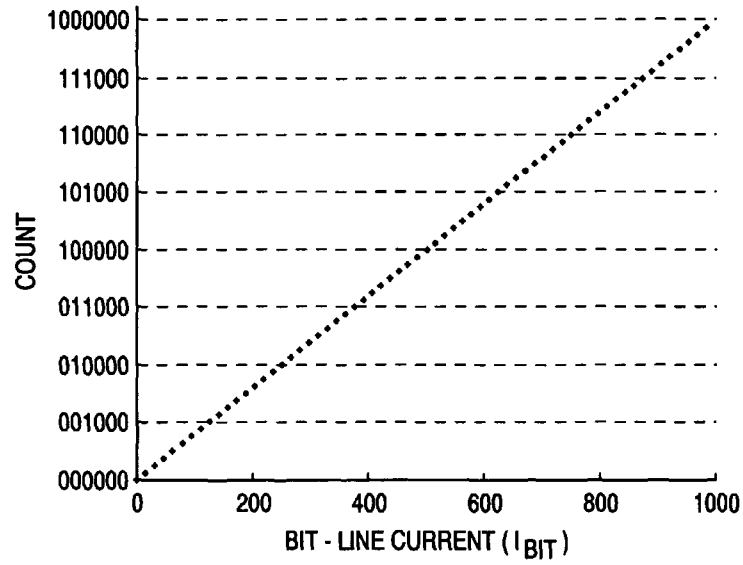
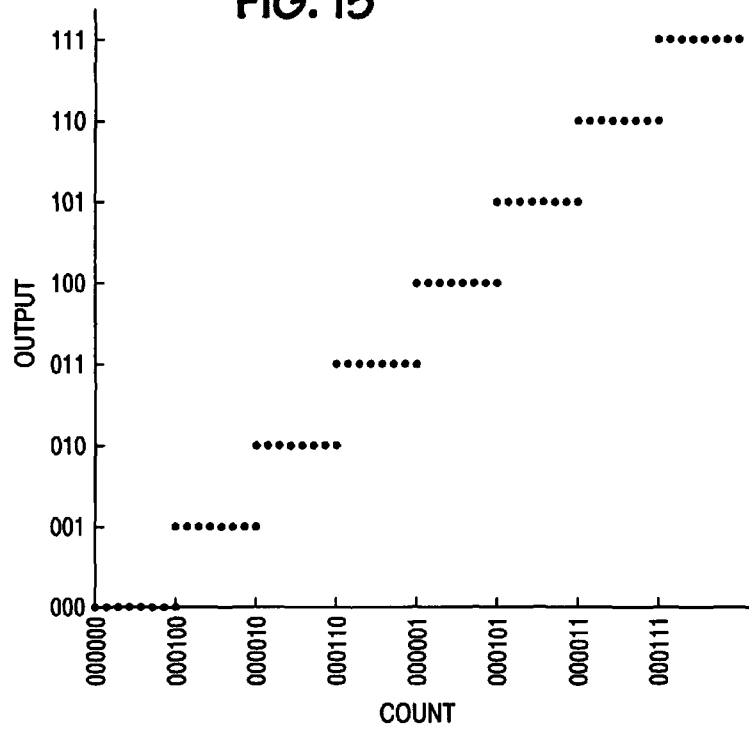

FIG. 15



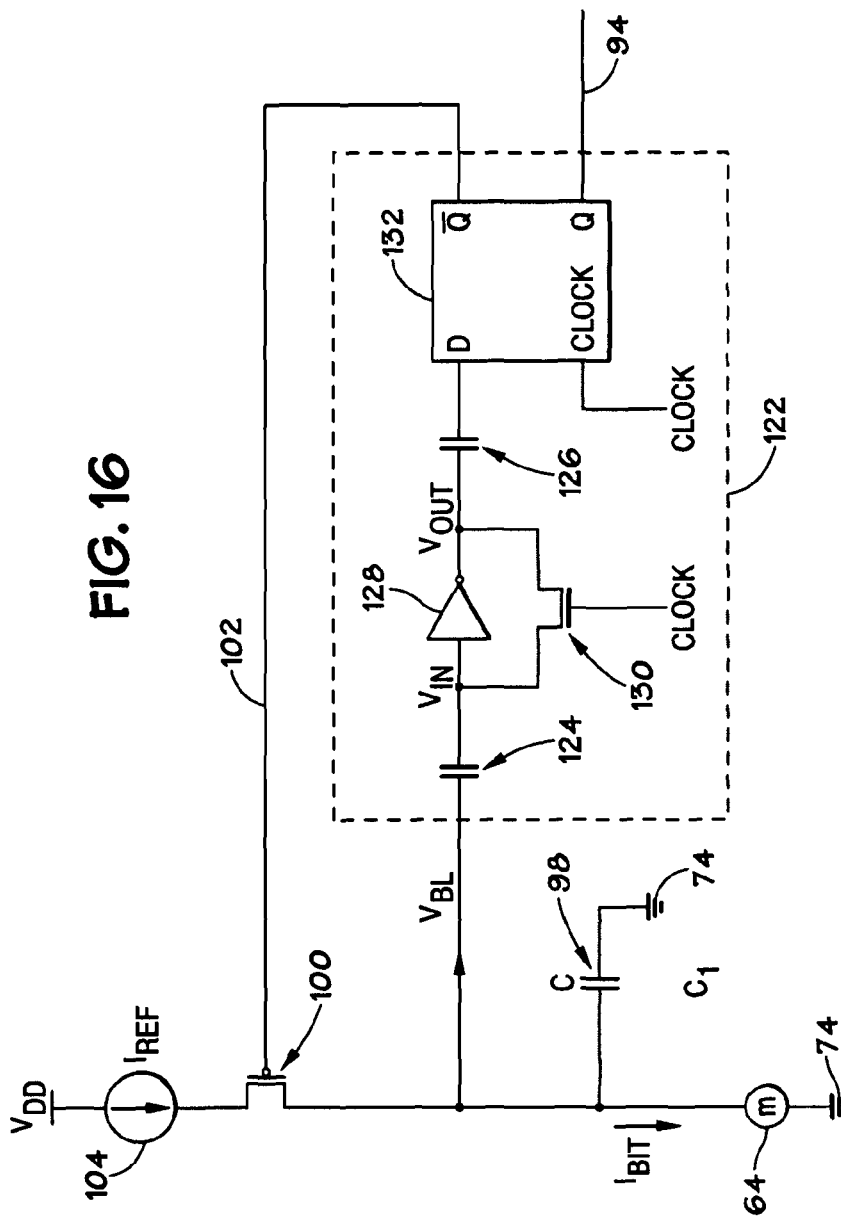
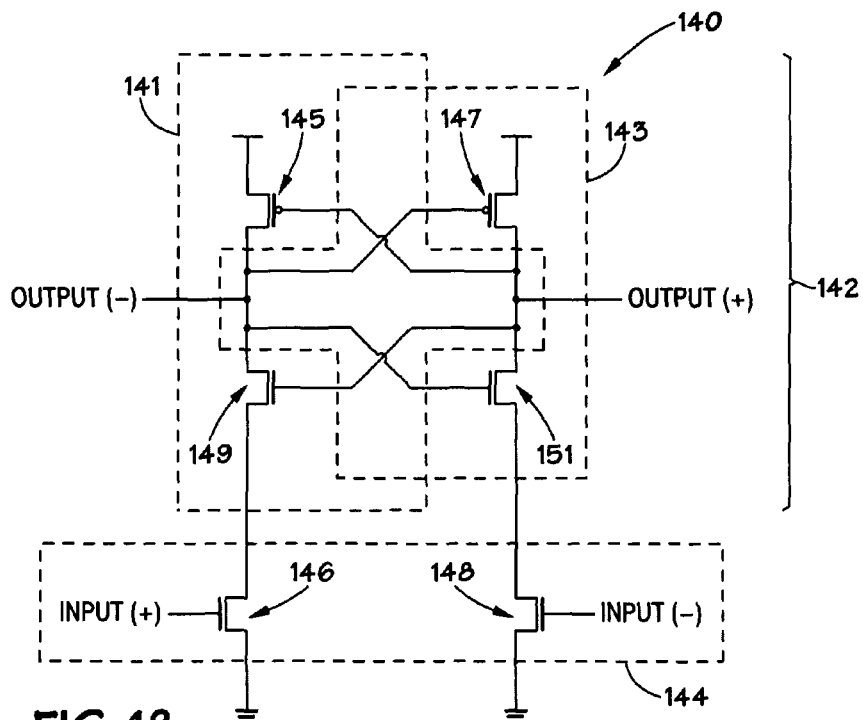
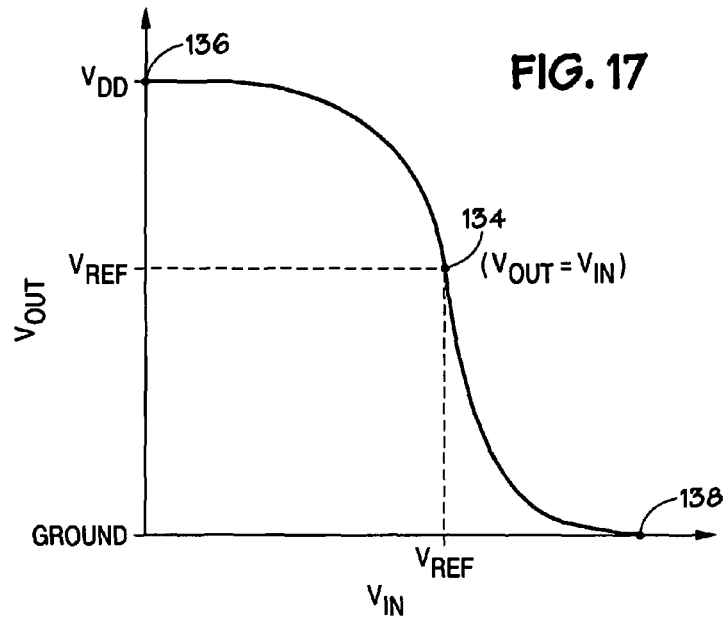

FIG. 16



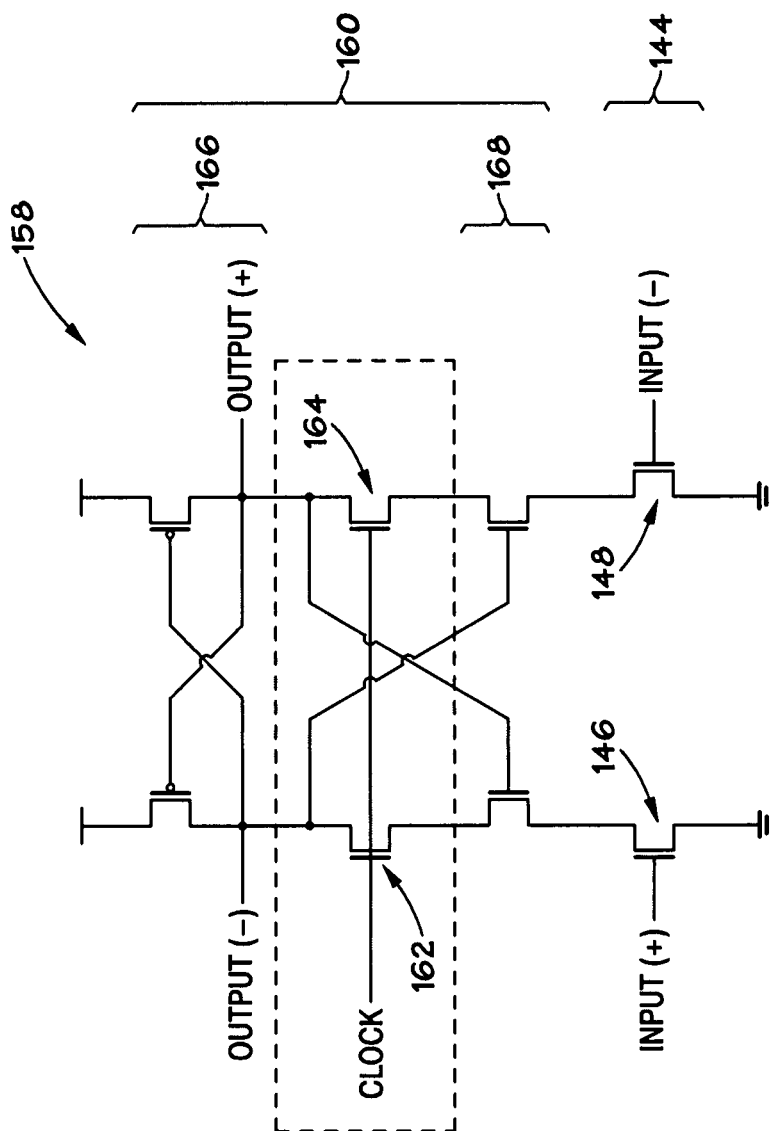

FIG. 19

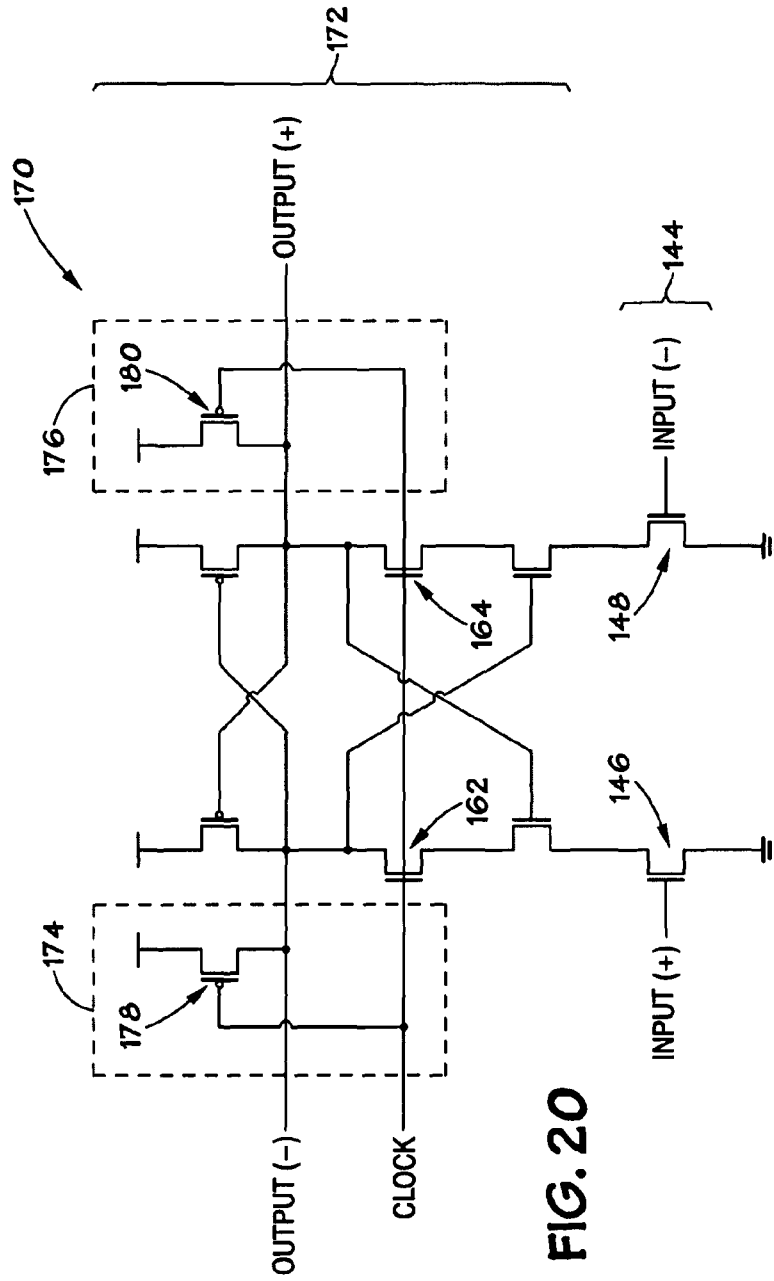
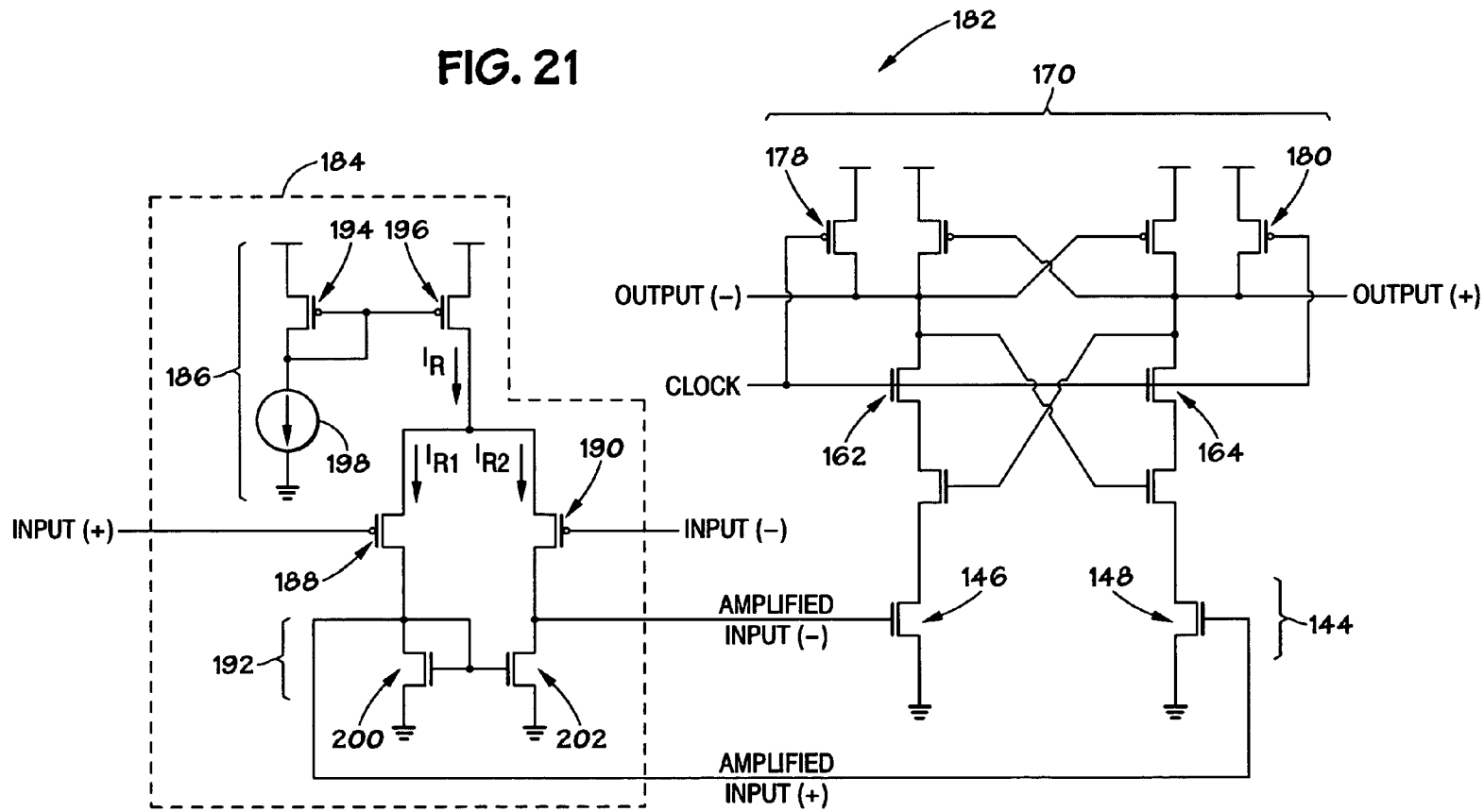

FIG. 20

FIG. 21



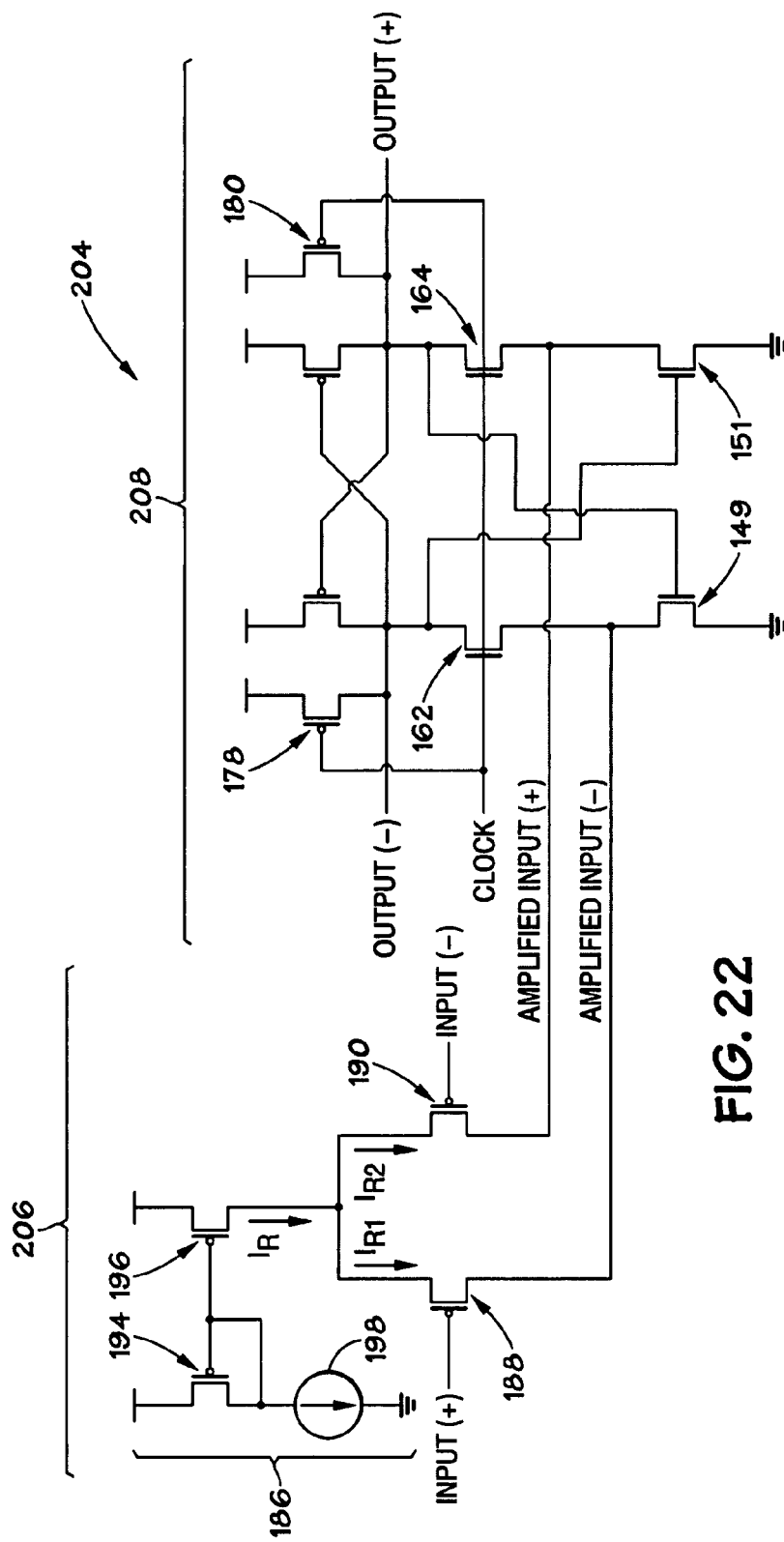

FIG. 22

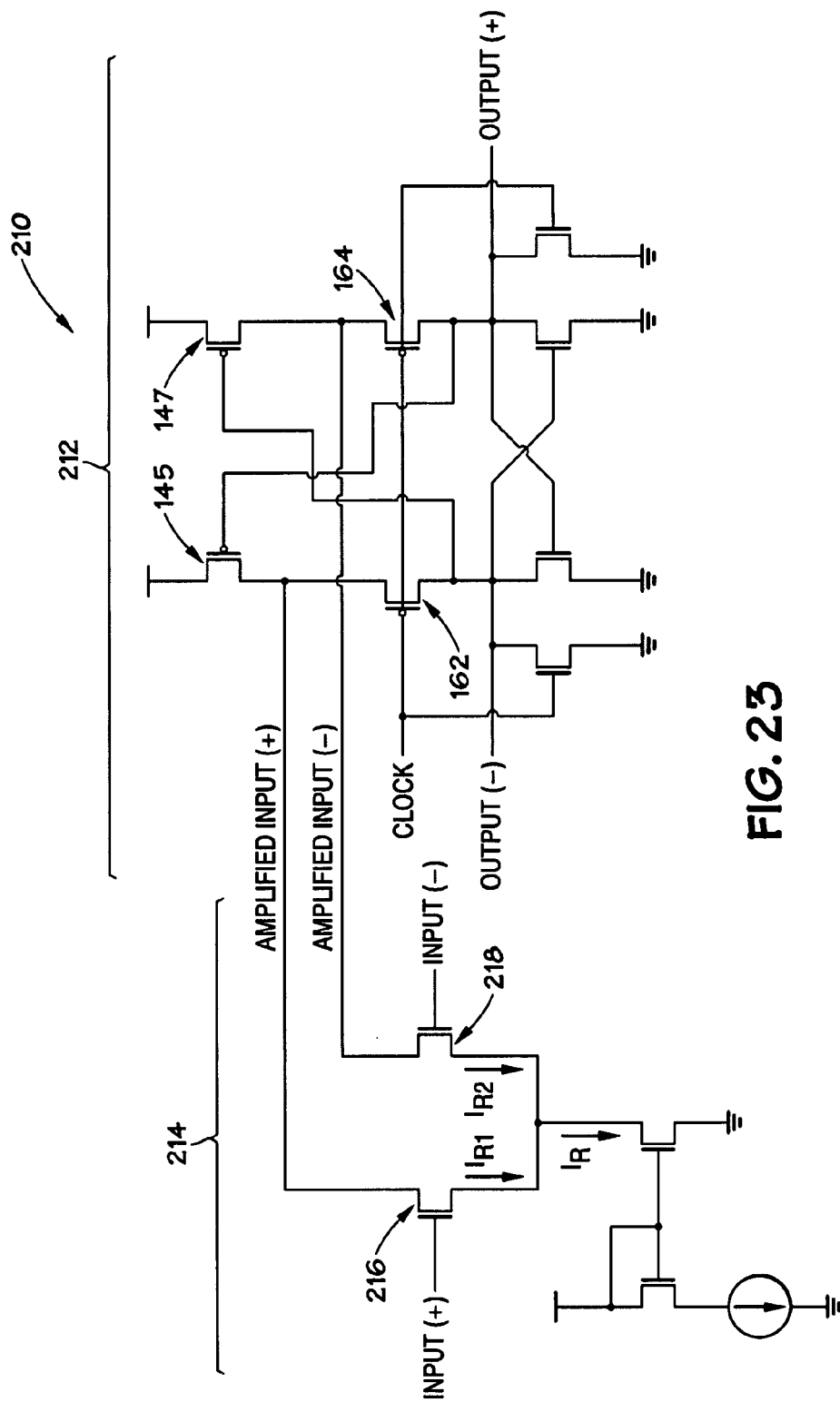

FIG. 23

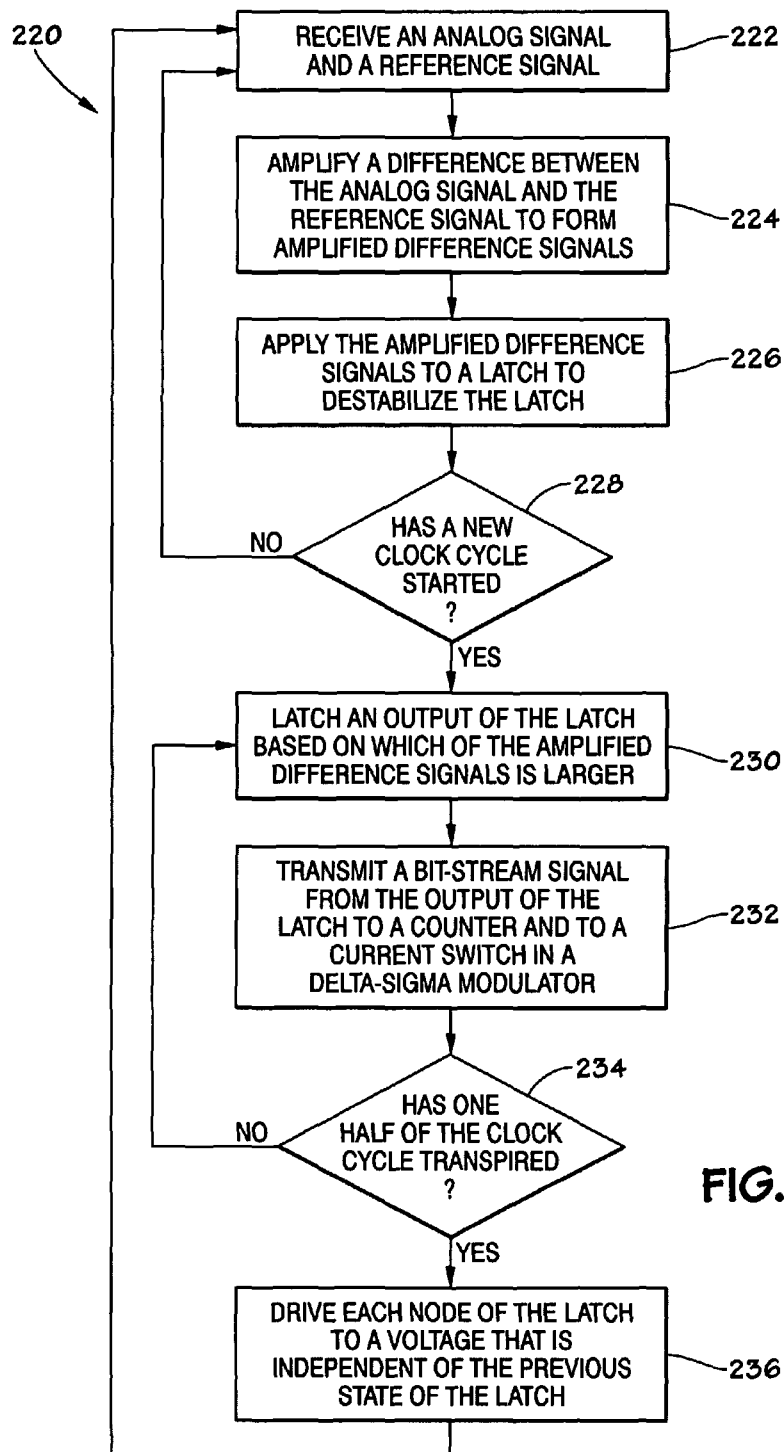

FIG. 24

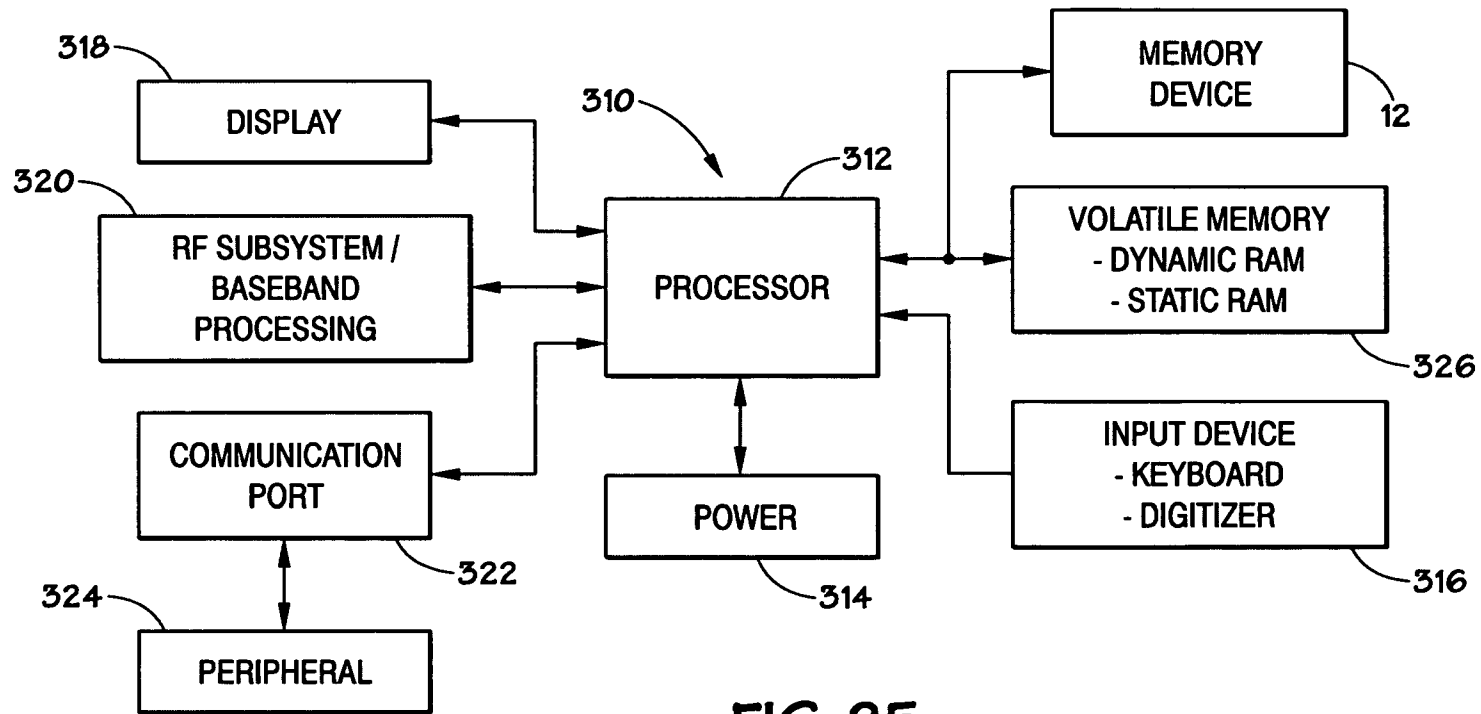

FIG. 25

COMPARATORS FOR DELTA-SIGMA MODULATORS

BACKGROUND

1. Field of Invention

Embodiments of the present invention relate generally to electronic devices and, more specifically, in a particular embodiment, to comparators for delta-sigma modulators in electronic devices.

2. Description of Related Art

Generally, memory devices include an array of memory elements and associated sense amplifiers. The memory elements store data, and the sense amplifiers read the data from the memory elements. To read data, for example, a current is passed through the memory element, and the current or a resulting voltage is measured by the sense amplifier. Conventionally, the sense amplifier measures the current or voltage by comparing it to a reference current or voltage. Depending on whether the current or voltage is greater than the reference, the sense amplifier outputs a value of one or zero. That is, the sense amplifier quantizes the analog signal from the memory element into one of two logic states.

Many types of memory elements are capable of assuming more than just two states. For example, some memory elements are capable of multi-bit (e.g., more than two state) storage. For instance, rather than outputting either a high or low voltage, the memory element may output four or eight different voltage levels, each level corresponding to a different data value. However, conventional sense amplifiers often fail to distinguish accurately between the additional levels because the difference between the levels (e.g., a voltage difference) in a multi-bit memory element is often smaller than the difference between the levels in a single-bit (i.e., two state) memory element. Thus, conventional sense amplifiers often cannot read multi-bit memory elements. This problem may be increased as high performance multi-bit memory elements become increasingly dense, thereby reducing the size of the memory elements and the difference between the levels (e.g., voltage) to be sensed by the sense amplifiers.

A variety of factors may tend to prevent the sense amplifier from discerning small differences in the levels of a multi-bit memory element. For instance, noise in the power supply, ground, and reference voltage may cause an inaccurate reading of the memory element. The noise may have a variety of sources, such as temperature variations, parasitic signals, data dependent effects, and manufacturing process variations. This susceptibility to noise often leads a designer to reduce the number of readable states of the memory element, which tends to reduce memory density and increase the cost of memory.

Conventional sense amplifiers present similar problems in imaging devices. In these devices, an array of light sensors output a current or voltage in response to light impinging upon the sensor. The magnitude of the current or voltage typically depends upon the intensity of the light. Thus, the capacity of the sense amplifier to accurately convert the current or voltage into a digital signal may determine, in part, the fidelity of the captured image. Consequently, noise affecting the sense amplifier may diminish the performance of imaging devices.

BRIEF DESCRIPTION OF DRAWINGS

FIG. 1 illustrates an electronic device in accordance with an embodiment of the present invention;

FIG. 2 illustrates a memory device in accordance with an embodiment of the present invention;

FIG. 3 illustrates a memory array in accordance with an embodiment of the present invention;

FIG. 4 illustrates a memory element in accordance with an embodiment of the present invention;

FIG. 5 illustrates I-V traces of memory elements storing different values, in accordance with an embodiment of the present invention;

FIG. 6 illustrates noise in the bit-line current during a read operation;

FIG. 7 illustrates a quantizing circuit in accordance with an embodiment of the present invention;

FIG. 8 illustrates a delta-sigma sensing circuit in accordance with an embodiment of the present invention;

FIGS. 9 and 10 illustrate current flow during operation of the quantizing circuit of FIG. 8;

FIGS. 11-13 illustrate voltages in the quantizing circuit of FIG. 8 when sensing small, medium, and large currents, respectively;

FIG. 14 is a graph of bit-line current versus counter output for the quantizing circuit of FIG. 8;

FIG. 15 is a graph of count versus quantizing circuit output in accordance with an embodiment of the present invention;

FIG. 16 illustrates an example of a comparator for a delta-sigma modulator in accordance with an embodiment of the present invention;

FIG. 17 is a graph illustrating the relationship between the input voltage and the output voltage for the comparator of FIG. 16;

FIG. 18 illustrates a second example of a comparator in accordance with an embodiment of the present invention;

FIG. 19 illustrates a third example of a comparator in accordance with an embodiment of the present invention;

FIG. 20 illustrates a fourth example of a comparator in accordance with an embodiment of the present invention;

FIG. 21 illustrates a fifth example of a comparator in accordance with an embodiment of the present invention;

FIG. 22 illustrates a sixth example of a comparator in accordance with an embodiment of the present invention;

FIG. 23 illustrates a seventh example of a comparator in accordance with an embodiment of the present invention;

FIG. 24 illustrates an example of a comparison process in accordance with an embodiment of the present invention; and

FIG. 25 illustrates an example of a system that includes the memory device of FIG. 2 in accordance with an embodiment of the present invention.

DETAILED DESCRIPTION OF SPECIFIC EMBODIMENTS

Various embodiments of the present invention are described below. In an effort to provide a concise description of these embodiments, not all features of an actual implementation are described in the specification. It should be appreciated that in the development of any such actual implementation, as in any engineering or design project, numerous implementation-specific decisions must be made to achieve the developers specific goals, such as compliance with system-related and business-related constraints, which may vary from one implementation to another. Moreover, it should be appreciated that such a development effort might be complex and time consuming but would nevertheless be a routine undertaking of design, fabrication, and manufacture for those of ordinary skill having the benefit of this disclosure.

Some of the subsequently described embodiments may address one or more of the problems with conventional sense

3

amplifiers discussed above. Some embodiments include a quantizing circuit configured to detect small differences in voltages and/or currents. As explained below, the quantizing circuit may sample the measured electrical parameter on multiple occasions and filter, e.g., average or sum, the samples to reduce the impact of noise. As a result, in some embodiments, the quantizing circuit may resolve small differences between voltage or current levels in multi-bit memory elements and/or light sensors, which may allow circuit designers to increase the number of bits stored per memory element and/or the sensitivity of an imaging device.

In the course of measuring the electrical parameter, the quantizing circuit may compare the electrical parameter to a reference signal with a comparator. In certain embodiments, the quantizing circuits may include comparators that consume less power than conventional comparators. As described below, during operation, the non-conventional comparators may reduce currents flowing to ground by performing comparisons relatively quickly and opening current paths during portions of a clock cycle. In some embodiments, a preamplifier may expedite comparisons by accentuating differences between signals being compared. These comparators are described below, after describing both examples of systems that employ quantizing circuits and specific examples of a quantizing circuit.

FIG. 1 depicts an electronic device 10 that may be fabricated and configured in accordance with one or more of the present embodiments. The illustrated electronic device 10 includes a memory device 12 that, as explained further below, may include multi-bit memory elements and quantizing circuits. Alternatively, or additionally, the electronic device 10 may include an imaging device 13 having the quantizing circuits.

Myriad devices may embody one or more of the present techniques. For example, the electronic device 10 may be a storage device, a communications device, an entertainment device, an imaging system, or a computer system, such as a personal computer, a server, a mainframe, a tablet computer, a palm-top computer, or a laptop.

FIG. 2 depicts a block diagram of an embodiment of the memory device 12. The illustrated memory device 12 may include a memory array 14, a quantizing circuit 16, a column decoder 18, a column address latch 20, row drivers 22, a row decoder 24, row address latches 26, and control circuitry 28. As described below with reference to FIG. 3, the memory array 14 may include a matrix of memory elements arranged in rows and columns. As will be appreciated, the imaging device 13 (FIG. 1) may include similar features except that in the case of an imaging device 13, the array 14 might comprise an array of imaging elements, such as complementary-metal-oxide semiconductor (CMOS) imaging elements or charge coupled devices (CCDs).

When accessing the memory elements, the control circuitry may receive a command to read from or write to a target memory address. The control circuitry 28 may then convert the target address into a row address and a column address. In the illustrated embodiment, the row address bus 30 transmits the row address to the row address latches 26, and a column address bus 32 transmits column address to the column address latches 20. After an appropriate settling time, a row address strobe (RAS) signal 34 (or other controlling clock signal) may be asserted by the control circuitry 28, and the row address latches 26 may latch the transmitted row address. Similarly, the control circuitry 28 may assert a column address strobe 36, and the column address latches 20 may latch the transmitted column address.

4

Once row and column addresses are latched, the row decoder 24 may determine which row of the memory array 14 corresponds to the latched row address, and the row drivers 22 may assert a signal on the selected row. Similarly, the column decoder 18 may determine which column of the memory array 14 corresponds with the latched column address, and the quantizing circuit 16 may quantize (e.g., sense) a voltage or current on the selected column. Additional details of reading and writing are described below.

FIG. 3 illustrates an example of a memory array 14. The illustrated memory array 14 includes a plurality of bit-lines 38, 40, 42, 44, and 46 (also referred to as BL0-BL4) and a plurality of word-lines 48, 50, 52, 54, 56, 58, 60, and 62 (also referred to as WL0-WL7). These bit-lines and word-lines are examples of electrical conductors. The memory array 14 further includes a plurality of memory elements 64, each of which may be arranged to intersect one of the bit-lines and one of the word-lines. In other embodiments, imaging elements may be disposed at each of these intersections.

The memory elements and imaging elements may be referred to generally as data locations, i.e., devices or elements configured to convey data, either stored or generated by a sensor, when sensed by a sensing circuit, such as the quantizing circuits discussed below. The data locations may be formed on an integrated semiconductor device (e.g., a device formed on a single crystal of silicon) that also includes the other components of the memory device 12 (or imaging device 13).

In some embodiments, the illustrated memory elements 64 are flash memory devices. The operation of the flash memory elements is described further below with reference to the FIGS. 4 and 5. It should be noted that, in other embodiments, the memory elements 64 may include other types of volatile or nonvolatile memory. For example, the memory elements 64 may include a resistive memory, such as a phase change memory or magnetoresistive memory. In another example, the memory elements 64 may include a capacitor, such as a stacked or trench capacitor. Some types of memory elements 64 may include an access device, such as a transistor or a diode associated with each of the memory elements 64, or the memory elements 64 may not include an access device, for instance in a cross-point array.

FIG. 4 illustrates a circuit 66 that models the operation of an arbitrarily selected memory element 64, which is disposed at the intersection of WL3 and BL0. This circuit 66 includes a capacitor 68, a pre-drain resistor 70 (R_{PD}), a post-source resistor 72 (R_{PS}), and a ground 74. The resistors 70 and 72 model the other devices in series with the memory element 64 being sensed. The illustrated memory element 64 includes a gate 76, a floating gate 78, a drain 80, and a source 82. In the circuit 66, the drain 80 and source 82 are disposed in series between the pre-drain resistor 70 and the post-source resistor 72. The gate 76 is connected to WL3. The pre-drain resistor 70, the drain 80, the source 82, and the post-source resistor 72 are disposed in series on the bit-line BL0. The capacitor 68, which models the capacitance of the bit-line, has one plate connected to ground 74 and another plate connected to the bit-line BL0, in parallel with the memory elements 64.

Several of the components of the circuit 66 represent phenomenon affecting the memory elements 64 when it is sensed. The pre-drain resistor 70 generally represents the drain-to-bitline resistance of the memory elements 64 connected to the bit-line above (i.e., up current from) WL3 when these memory elements 64 are turned on, (e.g., during a read operation). Similarly, the post source resistor 72 generally corresponds to the source-to-ground resistance of the memory elements 64 connected to the bit-line below WL3

when the memory element **64** is sensed. The circuit **66** models electrical phenomena associated with reading the memory elements **64** at the intersection of WL3 and BL0.

The operation of the memory elements **64** will now be briefly described with reference to FIGS. **4** and **5**. FIG. **5** illustrates one potential relationship between the bit-line current (I_{BIT}), the word-line voltage (V_{WL}), and the voltage of the floating gate **78** (V_{FG}). As illustrated by FIG. **5**, V_{FG} affects the response of the memory element **64** to a given V_{WL} . Decreasing the voltage of the floating gate shifts the I-V curve of the memory elements **64** to the right. That is, the relationship between the bit-line current and a word-line voltage depends on the voltage of the floating gate **78**. The memory elements **64** may store data by exploiting this effect.

To write data to the memory elements **64**, a charge corresponding to the data may be stored on the floating gate **78**. The charge of the floating gate **78** may be modified by applying voltages to the source **82**, drain **80**, and/or gate **76** such that the resulting electric fields produce phenomenon like Fowler-Northam tunneling and/or hot-electron injection near the floating gate **78**. Initially, the memory elements **64** may be erased by applying a word-line voltage designed to drive electrons off of the floating gate **78**. In some embodiments, an entire column or block of memory elements **64** may be erased generally simultaneously. Once the memory elements **64** are erased, the gate **76** voltage may be manipulated to drive a charge onto the floating gate **78** that is indicative of a data value. After the write operation ends, the stored charge may remain on the floating gate **78** (i.e., the memory elements **64** may store data in a nonvolatile fashion).

As illustrated by FIG. **5**, the value stored by the memory element **64** may be read by applying a voltage, V_{WL} , to the gate **76** and quantizing (e.g., categorizing) a resulting bit-line current, I_{BIT} . Each of the I-V traces depicted by FIG. **5** correspond to a different charge stored on the floating gate, V_{FG} , which should not be confused with the voltage that is applied to the gate, V_{WL} . The difference in floating gate **70** voltage, V_{FG} , between each I-V trace is an arbitrarily selected scaling factor "x." The illustrated I-V traces correspond to eight-different data values stored by the memory element **64**, with a V_{FG} of 0x representing a binary data value of 000, a V_{FG} of 1x representing a binary data value of 001, and so on through V_{FG} of 7x, which represents a binary data value of 111. Thus, by applying a voltage to the gate **76** and measuring the resulting bit-line current, the charge stored on the floating gate **78** may be sensed, and the stored data may be read.

The accuracy with which the bit-line current is quantized may affect the amount of data that a designer attempts to store in each memory element **64**. For example, in a system with a low sensitivity, a single bit may be stored on each memory element **64**. In such a system, a floating gate voltage V_{FG} of 0x may represent a binary value of 0, and a floating gate voltage V_{FG} of $-7x$ may represent a binary value of one. Thus, the difference in floating gate voltages V_{FG} corresponding to different data values may be relatively large, and the resulting differences and bit-line currents for different data values may also be relatively large. As a result, even low-sensitivity sensing circuitry may quantize (e.g., discern) these large differences in bit-line current during a read operation. In contrast, high-sensitivity sensing circuitry may facilitate storing more data in each memory element **64**. For instance, if the sensing circuitry can distinguish between the eight different I-V traces depicted by FIG. **5**, then the memory elements **64** may store three bits. That is, each of the eight different charges stored on the floating gate **78** may represent a different three-bit value: 000, 001, 010, 011, 100, 101, 110, or 111. Thus,

circuitry that precisely quantizes the bit-line current I_{BIT} may allow a designer to increase the amount of data stored in each memory element **64**.

However, as mentioned above, a variety of effects may interfere with accurate measurement of the bit-line current. For instance, the position of the memory elements **64** along a bit-line may affect R_{PD} and R_{PS} , which may affect the relationship between the word-line voltage V_{WL} and the bit-line current I_{BIT} . To illustrate these effects, FIG. **6** depicts noise on the bit-line while reading from the memory element **64**. As illustrated, noise in the bit-line current I_{BIT} may cause the bit-line current I_{BIT} to fluctuate. Occasionally, the fluctuation may be large enough to cause the bit-line current I_{BIT} to reach a level that represents a different stored data value, which could cause the wrong value to be read from the memory elements **64**. For instance, if the bit-line current is sensed at time **84**, corresponding to an arbitrarily selected peak, a data value of 100 may be read rather than the correct data value of 011. Similarly, if the bit-line current is sensed at time **86**, corresponding to an arbitrarily selected local minimum, a data value of 010 may be read rather than a data value of 011. Thus, noise on the bit-line may cause erroneous readings from memory elements **64**.

FIG. **7** depicts a quantizing circuit **16** that may tend to reduce the likelihood of an erroneous reading. The illustrated quantizing circuit **16** includes an analog-to-digital converter **88** and a digital filter **90** connected to each of the bit-lines **38**, **40**, **42**, **44**, and **46**, respectively. Each bit-line **38**, **40**, **42**, **44**, and **46** may connect to a different analog-to-digital converter **88** and digital filter **90**. The digital filters **90**, in turn, may connect to an input/output bus **92**, which may connect to a column decoder **18**, a column address latch **20**, and/or control circuitry **28** (see FIG. **2**).

In operation, the quantizing circuit **16** may quantize (e.g., digitize) analog signals from the memory elements **64** in a manner that is relatively robust to noise. As explained below, the quantizing circuit **16** may do this by converting the analog signals into a bit-stream and digitally filtering high-frequency components from the bit-stream.

The analog-to-digital converter **88** may be a one-bit, analog-to-digital converter or a multi-bit, analog-to-digital converter. In the present embodiment, an analog-to-digital converter **88** receives an analog signal from the memory element **64**, e.g., a bit-line current I_{BIT} or a bit-line voltage V_{BL} , and outputs a bit-stream that represents the analog signal. The bit-stream may be a one-bit, serial signal with a time-averaged value that generally represents the time-averaged value of the analog signal from the memory element **64**. That is, the bit-stream may fluctuate between values of zero and one, but its average value, over a sufficiently large period of time, may be proportional to the average value of the analog signal from the memory element **64**. In certain embodiments, the bit-stream from the analog-to-digital converter **88** may be a pulse-density modulated (PDM) version of the analog signal. The analog-to-digital converter **88** may transmit the bit-stream to the digital filter **90** on a bit-stream signal path **94**.

The digital filter **90** may digitally filter high-frequency noise from the bit-stream. To this end, the digital filter **90** may be a low-pass filter, such as a counter, configured to average (e.g., integrate and divide by the sensing time) the bit-stream over a sensing time, i.e., the time period over which the memory element **64** is read. (Alternatively, in some embodiments, the digital filter **90** is configured to integrate the bit-stream without dividing by the sensing time.) As a result, the digital filter **90** may output a value that is representative of both the average value of the bit-stream and the average value of the analog signal from the memory element **64**. In some

embodiments, the digital filter **90** is a counter, and the cut-off frequency of the digital filter **90** may be selected by adjusting the duration of the sensing time. In the present embodiment, increasing the sensing time will lower the cutoff frequency. That is, the frequency response of the digital filter **90** may be modified by adjusting the period of time over which the bit-stream is integrated and/or averaged before outputting a final value. The frequency response of the digital filter **90** is described further below with reference to FIG. **15**. For multi-bit memory elements **64**, the output from the digital filter **90** may be a multi-bit binary signal, e.g., a digital word that is transmitted serially and/or in parallel.

Advantageously, in certain embodiments, the quantizing circuit **16** may facilitate the use of multi-bit memory elements **64**. As described above, in traditional designs, the number of discrete data values that a memory element **64** stores may be limited by sense amps that react to noise. In contrast, the quantizing circuit **16** may be less susceptible to noise, and, as a result, the memory elements **64** may be configured to store additional data. Without the high frequency noise, the intervals between signals representative of different data values may be made smaller, and the number of data values stored by a given memory element **64** may be increased. Thus, beneficially, the quantizing circuit **16** may read memory elements **64** that store several bits of data, e.g., 2, 3, 4, 5, 6, 7, 8, or more bits per memory element **64**.

Although the quantizing circuit **16** may sense the signal from the memory element **64** over a longer period of time than conventional designs, the overall speed of the memory device **12** may be improved. As compared to a conventional device, each read or write operation of the memory device **12** may transfer more bits of data into or out of the memory element **64**. As a result, while each read or write operation may take longer, more data may be read or written during the operation, thereby improving overall performance. Further, in some memory devices **12**, certain processes may be performed in parallel with a read or write operation, thereby further reducing the overall impact of the longer sensing time. For example, in some embodiments, the memory array **14** may be divided into banks that operate at least partially independently, so that, while data is being written or read from one bank, another bank can read or write data in parallel.

FIG. **8** illustrates details of one implementation of the quantizing circuit **16**. In this embodiment, the digital filter **90** is a counter, and the analog-to-digital converter **88** is a first-order delta-sigma modulator. The illustrated delta-sigma modulator **88** may include a latched comparator **96**, a capacitor **98**, and a switch **100**. In other embodiments, other types of digital filters and analog-to-digital converters may be employed, such as those described below in reference to FIGS. **17** and **18**.

As illustrated, an input of the counter **90** may connect to the bit-stream signal path **94**, which may connect to an output of the comparator **96**. The output of the comparator **96** may also connect to a gate of the switch **100** by a feedback signal path **102**. The output terminal (e.g., source or drain) of the switch **100** may connect in series to one of the bit-lines **38, 40, 42, 44, or 46**, and the input terminal of the switch **100** may connect to a reference current source **104** (I_{REF}). One plate of the capacitor **98** may connect to one of the bit-lines **38, 40, 42, 44, or 46**, and the other plate of the capacitor **98** may connect to ground.

The illustrated counter **90** counts the number of clock cycles that the bit-stream **94** is at a logic high value or logic low value during the sensing time. The counter may count up or count down, depending on the embodiment. In some embodiments, the counter **90** may do both, counting up one for each clock cycle that the bit-stream has a logic high value

and down one for each clock cycle that the bit-stream has a logic low value. Output terminals (**D0-D5**) of the counter **90** may connect to the input/output bus **92** for transmitting the count. The counter **90** may be configured to be reset to zero or some other value when a reset signal is asserted. In some embodiments, the counter **90** may be a series connection of D-flip flops, e.g., D-flip flops having SRAM or other memory for storing an initial value and/or values to be written to the memory element **64**.

In the illustrated embodiment, the clocked comparator **96** compares a reference voltage (V_{REF}) to the voltage of one of the bit-lines **38, 40, 42, 44, or 46** (V_{BL}), which may be generally equal to the voltage of one plate of the capacitor **98**. The comparator **96** may be clocked (e.g., falling and/or rising edge triggered), and the comparison may be performed at regular intervals based on the clock signal, e.g., once per clock cycle. Additionally, the comparator **96** may latch, i.e., continue to output, values (V_{FB}) between comparisons. Thus, when the clock signals the comparator **96** to perform a comparison, if V_{BL} is less than V_{REF} , then the comparator **96** may latch its output to a logic low value, as described below in reference to FIG. **9**. Conversely, if V_{BL} is greater than V_{REF} , then the comparator **96** may latch a logic high value on its output, as described below in reference to FIG. **10**. As a result, the illustrated comparator **96** outputs a bit-stream that indicates whether V_{BL} is larger than V_{REF} , where the indication is updated once per clock cycle.

Advantageously, in some embodiments, the quantizing circuit **16** may include a single comparator (e.g., not more than one) for each column of multi-level memory elements **64**. In contrast, conventional sense amplifiers often include multiple comparators to read from a multi-bit memory cell, thereby potentially increasing device complexity and cost.

The capacitor **98** may be formed by capacitive coupling of the bit-lines **38, 40, 42, 44, and 46**. In other designs, this type of capacitance is referred to as parasitic capacitance because it often hinders the operation of the device. However, in this embodiment, the capacitor **98** may be used to integrate differences between currents on the bit-lines **38, 40, 42, 44, or 46** and the reference current to form the bit-stream, as explained further below. In some embodiments, the capacitor **98** may be supplemented or replaced with an integrated capacitor that provides greater capacitance than the "parasitic" bit-line capacitance.

The illustrated switch **100** selectively transmits current I_{REF} from the reference current source **104**. In various embodiments, the switch **100** may be a PMOS transistor (as illustrated in FIGS. **8-10**) or an NMOS transistor (as illustrated in FIG. **17**) controlled by the V_{signal} on the feedback signal path **102**.

The operation of the quantizing circuit **16** will now be described with reference to FIGS. **9-12**. Specifically, FIGS. **9** and **10** depict current flows in the quantizing circuit **16** when the comparator **96** is latched low and high, respectively. FIG. **11** illustrates V_{BL} , the bit-stream output from the comparator **96**, and the corresponding increasing count of the counter **90** for a relatively small bit-line current. FIG. **12** depicts the same voltages when measuring a medium sized bit-line current, and FIG. **13** depicts these voltages when measuring a relatively large bit-line current.

To sense the current through the memory element **64**, the illustrated delta-sigma modulator **88** exploits transient effects to output a bit-stream representative of the bit-line current I_{BIT} . Specifically, the delta-sigma modulator **88** may repeatedly charge and discharge the capacitor **98** with a current divider that subtracts the bit-line current I_{BIT} from the reference current I_{REF} . Consequently, a large current through the

memory element 64 may rapidly discharge the capacitor 98, and a small current through the memory element 64 may slowly discharge the capacitor 98.

To charge and discharge the capacitor 98, the delta-sigma modulator 88 switches between two states: the state depicted by FIG. 9 (hereinafter “the charging state”) and the state depicted by FIG. 10 (hereinafter “the discharging state”). Each time the delta-sigma modulator 88 transitions between these states, the bit-stream changes from a logic high value to a logic low value or vice versa. The proportion of time that the delta-sigma modulator 88 is in the state illustrated by either FIGS. 9 or FIG. 10 may be proportional to the size of the bit-line current I_{BIT} through the memory element 64. The larger the bit-line current I_{BIT} , the more time that the delta-sigma modulator 88 is in the state illustrated by FIG. 9, rather than the state illustrated by FIG. 10, and the more time that the bit-stream has a logic low value.

Starting with the charging state (FIG. 9), the capacitor 98 may initially accumulate a charge (e.g., become more charged). To this end, the output of the comparator 96 is latched to logic low, which, as mentioned above, may occur when V_{BL} is less than V_{REF} . The logic low may be conveyed to switch 100 by the feedback signal path 102, and the switch 100 may close, thereby conducting the reference current I_{REF} through one of the bit-lines 38, 40, 42, 44, or 46, as indicated by the larger arrows in FIG. 9. A portion of the electrons flowing through the reference current source 104 may be accumulated by the capacitor 98, as indicated by the smaller-horizontal arrows, and the remainder may be conducted through the memory element 64, i.e., the bit-line current I_{BIT} , as indicated by the smaller vertical arrows. Thus, the capacitor 98 may accumulate a charge, and V_{BL} may increase.

The comparator 96 and the reference current source 104 may cooperate to charge the capacitor 98 for a discrete number of clock cycles. That is, when the delta-sigma modulator 88 transitions to the charging state, the delta-sigma modulator 88 may remain in this state for an integer number of clock cycles. In the illustrated embodiment, the comparator 96, the output of which is latched, changes state no more than once per clock cycle, so the switch 100, which is controlled by the output of the comparator 96, V_{FB} , conducts current for a discrete number of clock cycles. As a result, the reference current source 104 conducts current I_{REF} through the bit-line and into the capacitor 98 for an integer number of clock cycles.

After each clock cycle of charging the capacitor 98, the delta-sigma modulator 88 may transition from the charging state to the discharging state, which is illustrated by FIG. 10, depending on the relative values of V_{BL} and V_{REF} . Once per clock cycle (or at some other appropriate interval, such as twice per clock cycle), the comparator 96 may compare the voltage of the capacitor V_{BL} to the reference voltage V_{REF} . If the capacitor 98 has been charged to the point that V_{BL} is greater than V_{REF} , then the output of the comparator 96 may transition to logic high, as illustrated in FIG. 10. The logic high signal may be conveyed to the switch 100 by the feedback signal path 102, thereby opening the switch 100. As a result, the reference current source 104 may cease conducting current through the memory element 64 and into the capacitor 98, and the capacitor 98 may begin to discharge through the memory element 64.

In the present embodiment, the delta-sigma modulator 88 discharges the capacitor 98 for a discrete number of clock intervals. After each clock cycle of discharging the capacitor 98, the delta-sigma modulator 88 compares V_{BL} to V_{REF} . If V_{BL} is still greater than V_{REF} , then the comparator 96 may continue to output a logic high signal, i.e., $V_{FB}=1$, and the

switch 100 remains open. On the other hand, if enough current has flowed out of the capacitor 98 that V_{BL} is less than V_{REF} , then the comparator 96 may output a logic low signal, i.e., $V_{FB}=0$, and the switch 100 may close, thereby transitioning the delta-sigma modulator 88 back to the charging state and initiating a new cycle.

The counter 90 may count the number of clock cycles that the delta-sigma modulator 88 is in either the charging state or the discharging state by monitoring the bit-stream signal path 94. The bit-stream signal path 94 may transition back and forth between logic high and logic low with the output of the comparator 96, V_{FB} , and the counter 90 may increment and/or decrement a count once per clock cycle (or other appropriate interval) based on whether the bit-stream is logic high or logic low. After the sensing time has passed, the counter 90 may output a signal indicative of the count on output terminals D0-D5. As explained below, the count may correspond, e.g., proportionally, to the bit-line current, I_{BIT} .

FIGS. 11-13 illustrate voltages V_{FB} and V_{BL} in the quantizing circuit 16 when reading data from a memory element 64. Specifically, FIG. 11 illustrates a low-current case, in which the value stored by the memory element 64 is represented by a relatively low bit-line current. Similarly, FIG. 12 illustrates a medium-current case, and FIG. 13 illustrates a high-current case. In each of these figures, the ordinate of the lower trace represents the voltage of the bit-stream signal path 94, V_{FB} , and the ordinate of the upper trace illustrates the bit-line voltage, V_{BL} . The abscissa in each of the traces represents time, with the lower trace synchronized with the upper trace, and the duration of the time axes is one sensing time 106.

As illustrated by FIG. 11, the counter 90 is initially preset to zero (or some other appropriate value) by applying a reset signal. In some embodiments, the delta-sigma modulator 88 may undergo a number of start-up cycles to reach steady-state operation before initiating the sensing time and resetting the counter 90. At the beginning of the illustrated read operation, the delta-sigma modulator 88 is in the charging state, which charges the capacitor 98 and increases V_{BL} , as indicated by dimension arrow 108. At the beginning of the next clock cycle, the comparator 96 compares the bit-line voltage to the reference voltage and determines that the bit-line voltage is greater than the reference voltage. As a result, the bit-stream signal path 94 (V_{FB}) transitions to a logic high voltage, and the delta-sigma modulator 88 transitions to the discharging state. Additionally, the counter 90 increments the count by one to account for one clock cycle of the bit-stream signal 94 holding a logic low value. Next, the charge stored on the capacitor 98 drains out through the memory element 64, and the bit-line voltage drops until the comparator 96 determines that V_{BL} is less than V_{REF} , at which point the cycle repeats. The cycle has a period 112, which may be divided into a charging portion 114 and a discharging portion 116. Once during each cycle in the sensing time 106, the count stored in the counter 90 may increase by one. At the end of the sensing time 106, the counter 90 may output the total count.

A comparison of FIG. 11 to FIGS. 12 and 13 illustrates why the count correlates with the bit-line current. In FIG. 13, the high-current case, the stored charge drains from the capacitor 98 quickly, relative to the other cases, because the bit-line current I_{BIT} is large and, as a result, the delta-sigma modulator 88 spends more time in the charging state than the discharging state. As a result, the bit-stream has a logic low value for a large portion of the sensing time 106, thereby increasing the count.

The capacitance of the capacitor 98 may be selected with both the clock frequency and the range of expected bit-line

currents in mind. For example, the capacitor **98** may be large enough that the capacitor **98** does not fully discharge (e.g., saturate) when the bit-line current I_{BIT} is either at its lowest expected value or at its highest expected value. That is, in some embodiments, the capacitor **98** generally remains in a transient state while reading the memory element **64**. Similarly, the frequency at which the comparator **96** is clocked may affect the design of the capacitor **98**. A relatively high frequency clock signal may leave the capacitor **98** with relatively little time to discharge or saturate between clock cycles, thereby leading a designer to choose a smaller capacitor **98**.

Similarly, the size of the reference current may be selected with the range of expected bit-line currents in mind. Specifically, in certain embodiments, the reference current is less than the largest expected bit-line current I_{BIT} , so that, in the case of maximum bit-line current I_{BIT} , the capacitor **98** can draw charge from the reference current while the rest of the reference current flows through the memory element **64**.

FIG. **14** illustrates the relationship between the bit-line current I_{BIT} and the count for the presently discussed embodiment. As illustrated by FIG. **14**, the count corresponds with (e.g., is generally proportional to) the bit-line current I_{BIT} . This relationship is described by the following equation (Equation 1), in which N_{ST} represents the number of clock cycles during the sensing time:

$$I_{BIT}/I_{REF} = \text{Count}/N_{ST}$$

Thus, in the illustrated embodiment, the count corresponds with (e.g., is indicative of) the bit-line current I_{BIT} , which corresponds with the value stored by the memory element **64**.

Advantageously, the quantizing circuit **16** may quantize (e.g., categorize) the bit-line current I_{BIT} as falling into one of a large number of categories, each of which is represented by an increment of the count. In doing so, in some embodiments, the quantizing circuit **16** may resolve small differences in the bit-line current I_{BIT} . The resolution of the quantizing circuit **16** may be characterized by the following equation (Equation 2), in which I_{MR} represents the smallest resolvable difference in bit-line current I_{BIT} , i.e., the resolution of the quantizing circuit **16**:

$$I_{MR} = I_{REF}/N_{ST}$$

Thus, the resolution of the quantizing circuit **16** may be increased by increasing the sensing time or the clock frequency or by decreasing I_{REF} , which may limit the maximum cell current since I_{MR} is less than I_{REF} .

The resolution of the quantizing circuit **16** may facilitate storing multiple bits in the memory element **64** or sensing multiple levels of light intensity in an image sensor element. For example, if the quantizing circuit **16** is configured to quantize (e.g., categorize) the bit-line current I_{BIT} into one of four different levels, then the memory element **64** may store two-bits of data or, if the quantizing circuit **16** is configured to categorize the bit-line current I_{BIT} into one of eight different current levels, then the memory element **64** may store three-bits of data. For the present embodiment, the number of bits stored by the memory element **64** may be characterized by the following equation (Equation 3), in which N_B represents the number of bits stored by a memory element **64** and I_{RANGE} represents the range of programmable bit-line currents through the memory element **64**:

$$N_B = \log(I_{RANGE}/I_{MR})/\log 2$$

In short, in the present embodiment, greater resolution translates into higher density data storage for a given memory element **64**.

FIG. **15** is a graph that illustrates one way in which the counter **90** may be configured to further reduce the effects of noise. In FIG. **15**, the abscissa represents the count, and the ordinate represents the output of the quantizing circuit **16**. In the present embodiment, the three-least-significant digits of the count are disregarded as potentially corrupted by noise. That is, D0-D2 (FIG. **8**) either do not connect to the input/output bus **92** or are not interpreted as conveying data that is stored by the memory element **64**. As a result, a range of counter values may represent a single data value stored by the memory element **64**. For example, in the present embodiment, count values ranging from 00 1000 to 00 1111 are construed as representing a data value of 001. Representing data in this manner may further reduce the effects of noise because, even if noise affects the count, in many embodiments, it would have to affect the count in a consistent manner over a substantial portion of the sensing time to affect the more significant digits of the count. That is, disregarding less significant digits may lower the cutoff frequency of the counter **90**. In other embodiments, fewer, more, or no digits may be truncated from the count as potentially representing noise.

Truncating less significant digits may introduce a rounding error, or a downward bias, in the output. This effect may be mitigated by presetting (e.g., driving latches to a particular state in advance of counting or storing a value in memory) the counter **90** in a manner that accounts for this bias. The counter **90** may be preset either before reading from the memory element **64** or before writing to the memory element **64**. In some embodiments, the preset value may be one-half of the size of the range of counter values that represent a single output value. In other words, if m digits are truncated from the output, then the counter **90** may be preset to one-half of 2^m before reading from a memory element **64** or before writing to the memory element **64**. In some embodiments, the memory in the counter **90** may store this preset value.

FIG. **16** illustrates another example of a delta-sigma modulator **120** that includes a more detailed example of a comparator **122**. In the present embodiment, the comparator **122** includes two capacitors **124** and **126**, an inverter **128**, a transistor **130**, and a flip-flop **132**. The illustrated capacitors **124** and **126** are disposed in series on either side of the inverter **128**. A plate of the capacitors **124** and **126**, in the present embodiment, is connected to the bit-line and an input of the flip-flop **132**, respectively. The transistor **130** may selectively connect the input and the output of the inverter **128** based on the clock signal. An inverted output of the flip-flop **132** may be fed back to the currents switch **100** via the feedback signal path **102** and the non-inverted output may connect to the bit-stream signal path **94**.

In operation, once per clock cycle (or some other period), the inverter **128** may determine whether an input voltage V_{IN} is greater than the reference voltage, which in this case is the threshold voltage of the inverter **128**. When the clock signal is asserted, the transistor **130** may equalize V_{IN} and V_{OUT} . As a result, the inverter **128** may be driven to a metastable state **134** illustrated by FIG. **17**, which illustrates the relationship between V_{IN} and the output voltage of the inverter V_{OUT} . When the clock signal cycles low, the inverter **128** may transition to one of two stable states **136** or **138**, depending upon an imbalance applied by V_{BL} . That is, if V_{BL} biases V_{IN} in a positive direction, then the inverter **128** may snap to the stable state **136** and V_{OUT} may transition to logic high. On the other hand, if V_{BL} biases V_{IN} in a negative direction, then the inverter **128** may snap to the stable state **138** and output a logic low signal. Thus, depending on whether V_{BL} biases V_{IN} above or below the metastable state **134**, which corresponds

to V_{REF} for the comparator 122, the inverter 128 outputs either a logic high or a logic low signal.

The capacitors 124 and 126, in the present embodiment, may isolate the inverter 128, thereby preventing it from sending or receiving a DC current via other portions of the delta-sigma modulator 120. In other words, the capacitor 124 may transmit higher frequency changes in V_{BL} , while preventing currents from flowing between the bit line and the inverter 128. In a similar manner, the capacitor 126 may isolate the flip-flop 132.

During operation, the inverter 128 may draw more power than subsequently described embodiments. When the clock signal is asserted, a large current may flow to ground because the output of the inverter 128 and the input of the inverter 128 are coupled to one another. The power drawn by this current may be increased if the clock signal cycles low and the inverter 128 remains in a metastable state for a long period of time, e.g., if the imbalance applied by V_{BL} is small. Further, a large number of delta-sigma modulators operating simultaneously may multiply this effect.

FIG. 18 illustrates a comparator 140 that may consume less power than the comparator 122. The illustrated comparator 140 includes a latch 142 and a destabilization circuit 144, i.e., a circuit configured to create an imbalance in the latch 142. The latch 142 may include two cross-coupled inverters 141 and 143, which may each include a PMOS transistor 145 and 147 and an NMOS transistor 149 and 151. An output, labeled output (+), and its complement, labeled output (-), may convey the result of comparisons performed by the latch. The outputs (+) and (-) may couple to other components in a variety of ways, depending on the specific topology of the delta-sigma modulator. For instance, one of the outputs of the latch 142 may couple to the input of the flip-flop 132 (FIG. 16). In some embodiments, one output of the latch 142 may feed back to the current switch 100 and the other output may couple to the flip-flop 132 or the counter 90 (FIG. 10).

The illustrated destabilization circuit 144 includes two transistors 146 and 148 that are respectively controlled by a first input, labeled input (+), and a second input, labeled input (-). The inputs (+) and (-) may connect to other components of the delta-sigma modulator 88 (FIG. 8) or 120 (FIG. 16). For instance, one input, e.g., input (+), may connect to V_{BL} , and the input (-) may connect to V_{REF} . As explained below, the two transistors 146 and 148 may create an imbalance in the latch 142 based on the relative value of the inputs (+) and (-).

In operation, the outputs (+) and (-) may each be latched to a logic high or a logic low value depending on whether the input (+) is greater than the input (-). That is, if the input (+) is greater than the input (-), then the output (+) may latch to a logic high value, and the output (-) may latch to a logic low value. Conversely, if the input (+) is less than the input (-), then the output (+) may latch to a logic low value, and the output (-) may latch to a logic high value. To affect the outputs (+) and (-), in this embodiment, the inputs (+) and (-) create an imbalance in the latch 142 by controlling the currents through the transistors 146 and 148. In some embodiments, these transistors 146 and 148 may operate in their triode region, so their source-to-drain current is generally proportional to the voltage applied to their gate. The resulting difference in current may create the imbalance in the latch 142 and cause the latch to snap to one of the two above-mentioned stable states.

The comparator 140 has certain advantages and disadvantages relative to the other embodiments described herein, and thus may be more desirable for certain applications. Compared to the comparator 122 in FIG. 16, the comparator 140 may consume less power during periods of metastability. In

some embodiments, the source-to-drain resistance of the transistors 146 and 148 may resist the flow of currents to ground, thereby potentially limiting power consumption. Although it improves on the comparator 122 (FIG. 16) in this aspect, the comparator 140 may still draw significant current compared to subsequently described embodiments, especially when the latch 142 is in a metastable state and the transistors 146 and 148 are saturated.

FIG. 19 illustrates a comparator 158 that, in certain embodiments, further reduces the current flowing to ground. The comparator 158 may include a clocked latch 160 and the previously described destabilization circuit 144. The illustrated clocked latch 160 includes the components of the previously described latch 142 (FIG. 18) and transistors 162 and 164, which may be controlled by the clock signal. In the present embodiment, the transistors 162 and 164 are disposed between an upper portion of the latch 166 and a lower portion of the latch 168.

In operation, during a portion of each clock cycle, the transistors 162 and 164 may both prevent the comparator 158 from changing state and limit power consumption. When the clock signal is asserted, the clocked latch 160 may function in a manner similar to the previously discussed latch 142 (FIG. 18). When the clock signal is not asserted, the upper portion of the latch 166 may be isolated from the lower portion of the latch 168, thereby preventing current from flowing to ground and limiting power consumption. Further, the comparator 158 may remain latched in one state when the clock signal is not asserted. Because of this, the illustrated comparator 158 may be referred to as a clocked comparator. In some embodiments, the outputs (+) and/or (-) may be transmitted directly to the bit-stream 94 and the feedback signal path 102 (FIG. 8), without being latched by an intermediate flip-flop.

Although the comparator 158 may reduce power consumption compared to the previously discussed embodiments, it may exhibit a hysteresis, or memory, effect that could bias comparisons of the inputs (+) and (-). When the clock signal is not asserted, portions of the clocked latch 160 are potentially left floating, depending on the value of the outputs (+) and (-). As a result, when the clock signal is low, some of the nodes of the clocked latch 160 are at unknown voltages that depend on the previous state of the clocked latch 160. When the clock is re-asserted, charges on these floating portions may create an imbalance that counteracts the imbalance from the inputs (+) and (-), which could cause an erroneous reading.

FIG. 20 illustrates a comparator 170 that, in certain embodiments, may reduce or eliminate this hysteresis effect. The comparator 170, in the present embodiment, includes the destabilization circuit 144 and a latch 172, which may include the components of the latch 160 (FIG. 19) and reset circuits 174 and 176. As used herein, the term "reset circuits" refers to circuits configured to drive nodes, that would otherwise be floating, to a known voltage. The illustrated reset circuits 174 and 176 each include a transistor 178 or 180 that is controlled by the clock signal. In this embodiment, when the clock signal is low, the transistors 178 and 180 turn on and drive the portions of the latch 172 that would otherwise be floating to a known voltage. As a result, in this embodiment, when the clock signal transitions to logic high, the inputs (+) and (-) are the primary source of imbalance in the latch 172. Thus, the illustrated reset circuits 174 and 176 may tend to reduce hysteresis effects in the latch 172, and provide for a more accurate comparison.

Under certain conditions, the comparator 170 may still consume more power than the following embodiments. To initiate a comparison, the clock signal transitions to logic

high, and the latch 172 transitions to a stable state depending on the relative value of the inputs (+) and (-). At this point, in the present embodiment, current flows through the transistors 146 or 148 to ground until a stable state is reached or the clock signal cycles back to logic low. If the difference between the inputs (+) and (-) is relatively small, the latch 172 may remain in a metastable state, between the stable states, with current flowing to ground through the transistors 146 and 148, for a relatively long portion of a clock cycle. As a result, in some embodiments, the comparator 170 may consume more power when the difference between the inputs (+) and (-) is relatively small.

FIG. 21 illustrates a comparator 182 configured to reduce this effect by enhancing the difference between the inputs (+) and (-). The illustrated comparator 182 includes the components of the comparator 170 that were previously discussed with reference to FIG. 20 and a preamplifier 184. The preamplifier 184, in the present embodiment, is configured to amplify the difference between input (+) and (-) and apply that difference to the destabilization circuit 144, as described below. In some embodiments, the preamplifier may be referred to as a differential amplifier.

The illustrated preamplifier 184 includes a reference current source 186, two transistors 188 and 190, and a current mirror load 192. The illustrated reference current source 186 includes a current mirror formed by transistors 194 and 196 and a reference current 198, which may be formed by applying a relatively constant voltage across a resistor. The transistors 188 and 190 may be controlled by the inputs (+) and (-), respectively, and maybe sized such that they operate in their triode region. The current mirror 192 may include transistors 200 and 202, which may be disposed in series with the transistors 188 and 190, respectively.

In operation, the current mirror 186 may mirror a reference current from the reference current source 198 to produce I_R . This current may be divided into I_{R1} , which flows between the source and the drain of the transistor 188, and I_{R2} , which flows between the source and the drain of the transistor 190. In the present embodiment, both of these currents flow to ground through the current mirror 192. Thus, I_{R1} may be generally equal to I_{R2} . The voltage of the node between the transistor 188 and the current mirror 192 may constitute an Amplified Input (+) signal, and the voltage of the node between the transistor 190 and the current mirror 192 may constitute an Amplified Input (-) signal. The difference between the amplified inputs (+) and (-) may be larger than the difference between the inputs (+) and (-) by an amount that is generally proportional to the gain of the preamplifier 184.

Advantageously, the comparator 182 may incorporate the benefits of the previously discussed embodiments while consuming relatively little power, even when the difference between the inputs (+) and (-) is relatively small. In the previously described embodiments, a small difference in the inputs (+) and (-) could leave the latch 170 in a metastable state that draws large currents for a relatively long period of time. In the present embodiment, this effect is mitigated by the comparator 182 because the preamplifier 184 accentuates the difference between the inputs (+) and (-). Amplifying this difference may create a larger imbalance in the latch 170 and potentially minimize the amount of time that the latch 170 remains in a metastable state. As a result, in some embodiments, the comparator 182 may quickly reach a low-current, stable state and consume relatively little power.

The comparator 182 includes circuitry that may be simplified in other embodiments. For example, FIG. 22 illustrates a comparator 204 with a preamplifier 206 that feeds currents directly into a latch 208. That is, the preamplifier 206 outputs

a signal in the form of a current differential (in contrast to the preamplifier 184 (FIG. 21), which output a signal in the form of a voltage differential). The illustrated latch 208 includes the features of the latch 172 in FIG. 20 except that, in the present embodiment, the latch 208 and the latch 172 are different in two aspects: (1) the latch 208 couples directly to ground, rather than coupling to ground via the destabilization circuit 144; and (2) the latch 208 receives Amplified Inputs (+) and (-) at nodes between the transistors 162 and 164 and the transistors 149 and 151. These Amplified Inputs (+) and (-) apply a charge imbalance directly to the latch 208.

The illustrated preamplifier 206 includes the current mirror 186 and the transistors 188 and 190 but does not include certain other features, such as the current mirror load 192. In contrast to the illustrated preamplifier 184 (FIG. 21), the illustrated preamplifier 206 feeds the currents I_{R1} and I_{R2} directly to the latch 208 as the Amplified Inputs (+) and (-). These current signals may destabilize the latch 208 in a manner that is dependent on the relative magnitude of the inputs (+) and (-). Based on the imbalance created by the preamplifier 206, the latch 208 may output voltage signals that indicate whether input (+) is larger than input (-).

FIG. 23 illustrates another example of a comparator 210, which includes a latch 212 and a preamplifier 214. The comparator 210 is generally similar to the comparator 204 (FIG. 22) except that it is configured to employ NMOS transistors 216 and 218 rather than PMOS transistors in its preamplifier 214. The preamplifier 214 may be referred to as an NMOS preamplifier with a current differential output, and the preamplifier 206 (FIG. 22) may be referred to as a PMOS preamplifier with a current differential output.

In operation, the preamplifier 214 creates an imbalance within the latch 212 based on the relative magnitude of the inputs (+) and (-). To this end, in this embodiment, the preamplifier 214 sinks currents I_R and I_{R2} from the nodes between the transistors 162 and 164 and the transistors 145 and 147. The currents I_{R1} and I_{R2} form the Amplified Inputs (+) and (-). The imbalance created by the Amplified Inputs (+) and (-) is latched to the outputs (+) and (-) by the latch 212 once per clock cycle.

FIG. 24 illustrates an example of a comparison process 220, which may be performed by some of the previously described embodiments. The illustrated comparison process 220 begins with receiving an analog signal and a reference signal, as illustrated by block 222. This step may include receiving a bit-line voltage and a reference voltage, such as those illustrated by FIG. 8. In some embodiments, the analog signal and/or the reference signal may be a current.

Next, amplified difference signals are formed by amplifying a difference between the analog signal and the reference signal, as illustrated by block 224. The amplified difference signals may include two voltage signals or two current signals, depending on the embodiment. Each of the amplified difference signals may be applied to a different node of a latch to create an imbalance in the latch, as illustrated by block 226.

The illustrated process 220 includes determining whether a new clock cycle has started, as illustrated by block 228. A clock cycle is said to have started if an arbitrarily selected point in a clock cycle, such as a leading edge or a trailing edge, has occurred. If a new clock cycle has not started, then the process 220 returns to the block 222. If a new clock cycle has started, then an output of the latch is latched based on which of the amplified difference signals is larger in magnitude, as illustrated by block 230.

Next, a bit-stream signal from the output of the latch is transmitted to a counter and a current switch in a delta-sigma modulator, as illustrated by block 232. (The bit-stream in the

illustrated embodiment is binary, however in some embodiments, the bit-stream may assume more than two meaningful levels and convey more than a single bit at a time.) In some embodiments, the output is transmitted to only the current switch and the complement of the output is transmitted to the counter. This step may continue until one-half of the clock cycle has transpired, as illustrated by block 234. After one-half of the clock cycle has transpired, each node of the latch may be driven to a voltage that is independent of the previous state of the latch, as illustrated by block 236, and the process 220 may return to block 222.

FIG. 25 depicts an exemplary processor-based system 310 that includes the memory device 12. Alternatively or additionally, the system 310 may include the imaging device 13. The system 310 may be any of a variety of types such as a computer, pager, cellular phone, personal organizer, control circuit, etc. In a typical processor-based system, one or more processors 312, such as a microprocessor, control the processing of system functions and requests in the system 310. The processor 312 and other subcomponents of the system 310 may include quantizing circuits, such as those discussed above.

The system 310 typically includes a power supply 314. For instance, if the system 310 is a portable system, the power supply 314 may advantageously include a fuel cell, permanent batteries, replaceable batteries, and/or rechargeable batteries. The power supply 314 may also include an AC adapter, so the system 310 may be plugged into a wall outlet, for instance. The power supply 314 may also include a DC adapter such that the system 310 may be plugged into a vehicle cigarette lighter, for instance.

Various other devices may be coupled to the processor 312 depending on the functions that the system 310 performs. For instance, a user interface 316 may be coupled to the processor 312. The user interface 316 may include buttons, switches, a keyboard, a light pen, a mouse, a digitizer and stylus, and/or a voice recognition system, for instance. A display 318 may also be coupled to the processor 312. The display 318 may include an LCD, an SED display, a CRT display, a DLP display, a plasma display, an OLED display, LEDs, and/or an audio display, for example. Furthermore, an RF sub-system/baseband processor 320 may also be coupled to the processor 312. The RF sub-system/baseband processor 320 may include an antenna that is coupled to an RF receiver and to an RF transmitter (not shown). One or more communication ports 322 may also be coupled to the processor 312. The communication port 322 may be adapted to be coupled to one or more peripheral devices 324 such as a modem, a printer, a computer, or to a network, such as a local area network, remote area network, intranet, or the Internet, for instance.

The processor 312 generally controls the system 310 by implementing software programs stored in the memory. The memory is operably coupled to the processor 312 to store and facilitate execution of various programs. For instance, the processor 312 may be coupled to the volatile memory 326 which may include Dynamic Random Access Memory (DRAM) and/or Static Random Access Memory (SRAM). The volatile memory 326 is typically large so that it can store dynamically loaded applications and data. As described further below, the volatile memory 326 may be configured in accordance with embodiments of the present invention.

The processor 312 may also be coupled to the memory device 12. The memory device 12 may include a read-only memory (ROM), such as an EPROM, and/or flash memory to be used in conjunction with the volatile memory 326. The size of the ROM is typically selected to be just large enough to store any necessary operating system, application programs,

and fixed data. Additionally, the non-volatile memory 328 may include a high capacity memory such as a tape or disk drive memory.

The memory device 10 and volatile memory 326 may store various types of software, such as an operating system or office productivity suite including a word processing application, a spreadsheet application, an email application, and/or a database application.

While the invention may be susceptible to various modifications and alternative forms, specific embodiments have been shown by way of example in the drawings and have been described in detail herein. However, it should be understood that the invention is not intended to be limited to the particular forms disclosed. Rather, the invention is to cover all modifications, equivalents, and alternatives falling within the spirit and scope of the invention as defined by the following appended claims.

What is claimed is:

1. A device, comprising:

a data location;

a delta-sigma modulator directly coupled to the data location, wherein the delta-sigma modulator comprises a comparator, wherein the comparator comprises:
a preamplifier coupled to the data location; and
a latch coupled to an output of the preamplifier; and
a digital filter coupled to an output of the comparator, wherein the digital filter comprises a counter.

2. The device of claim 1, wherein the data location comprises a flash memory, a phase change memory, a magnetoresistive memory, or a photo-diode.

3. The device of claim 1, wherein the delta-sigma modulator is connected to the data location by a bit-line.

4. The device of claim 1, wherein the preamplifier comprises a differential amplifier configured to output an amplified voltage difference signal.

5. The device of claim 1, wherein the preamplifier comprises a differential amplifier configured to output an amplified current difference signal.

6. The device of claim 5, wherein the differential amplifier comprises a PMOS differential amplifier.

7. The device of claim 5, wherein the differential amplifier comprises an NMOS differential amplifier.

8. The device of claim 1, wherein the latch comprises a clocked latch.

9. The device of claim 8, comprising a reset circuit coupled to a clock signal.

10. The device of claim 1, wherein the preamplifier comprises a current source that includes a current mirror.

11. A device, comprising:

a data location;

a delta-sigma modulator directly coupled to the data location, wherein the delta-sigma modulator comprises a comparator, wherein the comparator comprises:
a preamplifier coupled to the data location wherein the preamplifier comprises a differential amplifier configured to output an amplified voltage difference signal; and
a latch coupled to an output of the preamplifier;

a digital filter coupled to an output of the comparator, wherein the digital filter comprises a counter; and
a destabilization circuit coupled to an output of the differential amplifier.

12. A system, comprising:

a device comprising:

a memory element; and

a delta-sigma modulator directly coupled to the memory element, the delta-sigma modulator comprising a

19

comparator that includes a differential amplifier, wherein inputs of the differential amplifier are coupled to the memory element and a reference signal, wherein the comparator comprises a latch coupled to the output of the differential amplifier, wherein the latch comprises cross-coupled inverters connected to a destabilization circuit, and wherein the latch is coupled to the differential amplifier via the destabilization circuit.

13. A system, comprising:
a device comprising:
a memory element; and
a delta-sigma modulator directly coupled to the memory element, the delta-sigma modulator comprising a comparator that includes a differential amplifier, wherein inputs of the differential amplifier are coupled to the memory element and a reference signal, wherein the comparator comprises a latch coupled to the output of the differential amplifier, wherein the latch comprises a reset circuit configured to drive a node of the latch to a voltage that is independent of a previous state of the latch, once per clock cycle.

14. A system, comprising:
a device comprising:
a memory element; and
a delta-sigma modulator directly coupled to the memory element, the delta-sigma modulator comprising a comparator that includes a differential amplifier, wherein inputs of the differential amplifier are coupled to the memory element and a reference signal, wherein the comparator comprises a latch coupled to the output of the differential amplifier, wherein a pair of current paths couple two nodes of the latch to two outputs of the differential amplifier, and wherein the differential amplifier is configured to conduct an amplified current difference signal via the pair of current paths.

20

15. A method, comprising:
amplifying a difference between an analog signal and a reference signal, wherein amplifying the difference comprises:
amplifying the analog signal to produce an amplified analog signal; and
amplifying the reference signal to produce an amplified reference signal;
latching an output based on which of the two amplified signals is larger to form a data-stream; and
digitally filtering the data-stream.

16. The method of claim 15, wherein the analog signal comprises a current indicative of data stored in a memory device.

17. The method of claim 15, wherein the analog signal comprises an analog signal indicative of an intensity of light impinging upon a light sensor.

18. The method of claim 15, comprising driving each node of the latch to a voltage that is independent of a previous state of the latch.

19. The method of claim 15, comprising transmitting the data-stream to a current switch in a delta-sigma modulator.

20. The method of claim 15, wherein the data-stream is a bit-stream.

21. A method, comprising:
amplifying a difference between an analog signal and a reference signal, wherein amplifying the difference comprises:
amplifying the analog signal to produce an amplified analog signal; and
amplifying the reference signal to produce an amplified reference signal;
latching an output based on which of the two amplified signals is larger to form a data-stream;
latching after a clock cycle has started;
ceasing latching after one half of the clock cycle has transpired; and
digitally filtering the data-stream.

* * * * *