



US006870784B2

(12) **United States Patent**
Baker

(10) **Patent No.:** **US 6,870,784 B2**
(45) **Date of Patent:** **Mar. 22, 2005**

(54) **INTEGRATED CHARGE SENSING SCHEME FOR RESISTIVE MEMORIES**

FOREIGN PATENT DOCUMENTS

(75) Inventor: **R. Jacob Baker**, Meridian, ID (US)

EP 1 152 429 A 11/2001
GB 1379856 A 1/1975
WO WO 03/067238 A 8/2003

(73) Assignee: **Micron Technology, Inc.**, Boise, ID (US)

* cited by examiner

(*) Notice: Subject to any disclaimer, the term of this patent is extended or adjusted under 35 U.S.C. 154(b) by 0 days.

Primary Examiner—Thong Q. Le
(74) *Attorney, Agent, or Firm*—Dickstein Shapiro Morin & Oshinsky LLP

(21) Appl. No.: **10/445,940**

(57) **ABSTRACT**

(22) Filed: **May 28, 2003**

An intergrated charge sensing scheme for sensing the resistance of a resistive memory element is described. The current through a resistive memory cell is used to charge a capacitor coupled to a digit line. The voltage on the capacitor, which corresponds to the voltage on the digit line, is applied to one input of a comparator. When the voltage on the bit line exceeds a predetermined fixed voltage applied to the second input to the comparator less an offset, the comparator switches logic state, charge is drawn off from the capacitor and the capacitor charges again. The process of charging and discharging the capacitor occurs during a predetermined time period and the number of times the capacitor switches during the time period represents the resistance of the memory element.

(65) **Prior Publication Data**

US 2004/0240294 A1 Dec. 2, 2004

(51) **Int. Cl.**⁷ **G11C 7/02**; G11C 7/00

(52) **U.S. Cl.** **365/209**; 365/189.07; 365/149

(58) **Field of Search** 365/209, 189.07, 365/226, 236, 149

(56) **References Cited**

U.S. PATENT DOCUMENTS

5,953,276 A 9/1999 Baker
2002/0008987 A1 1/2002 Koichi et al.
2003/0156463 A1 * 8/2003 Casper et al. 365/189.07

33 Claims, 4 Drawing Sheets

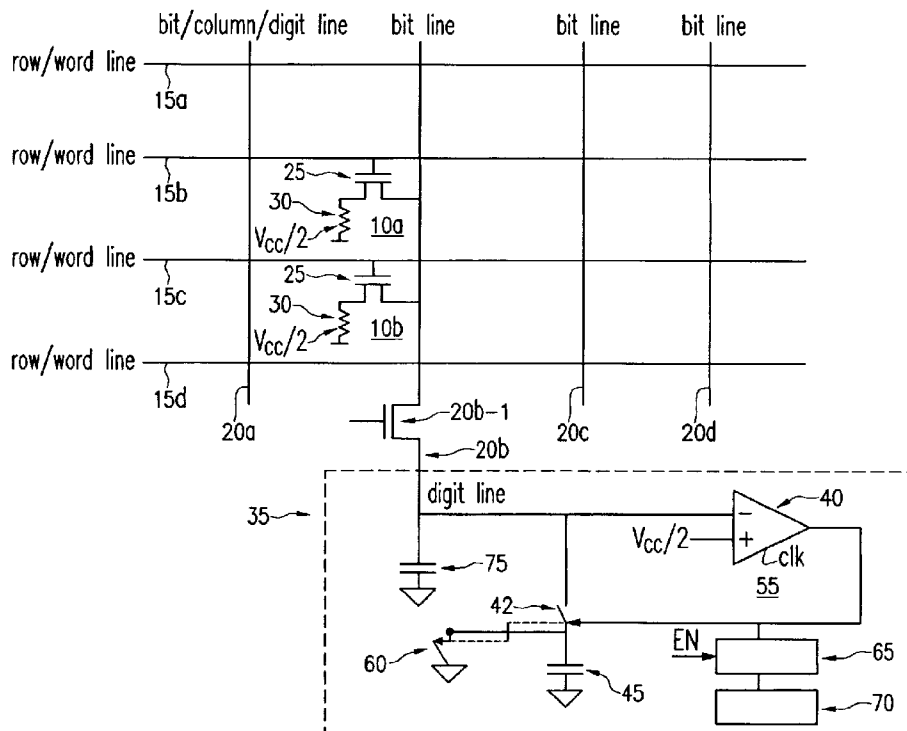

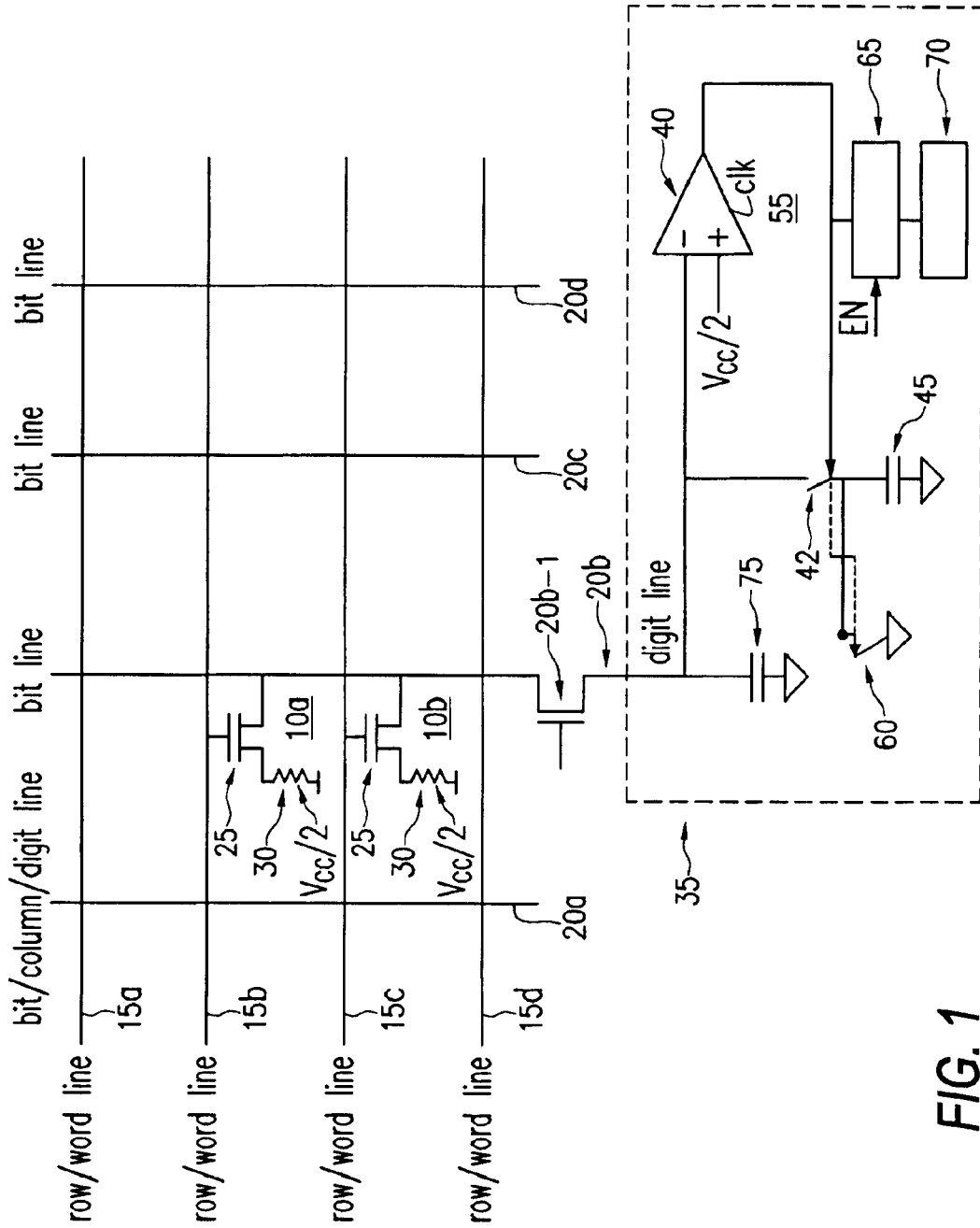

FIG. 1

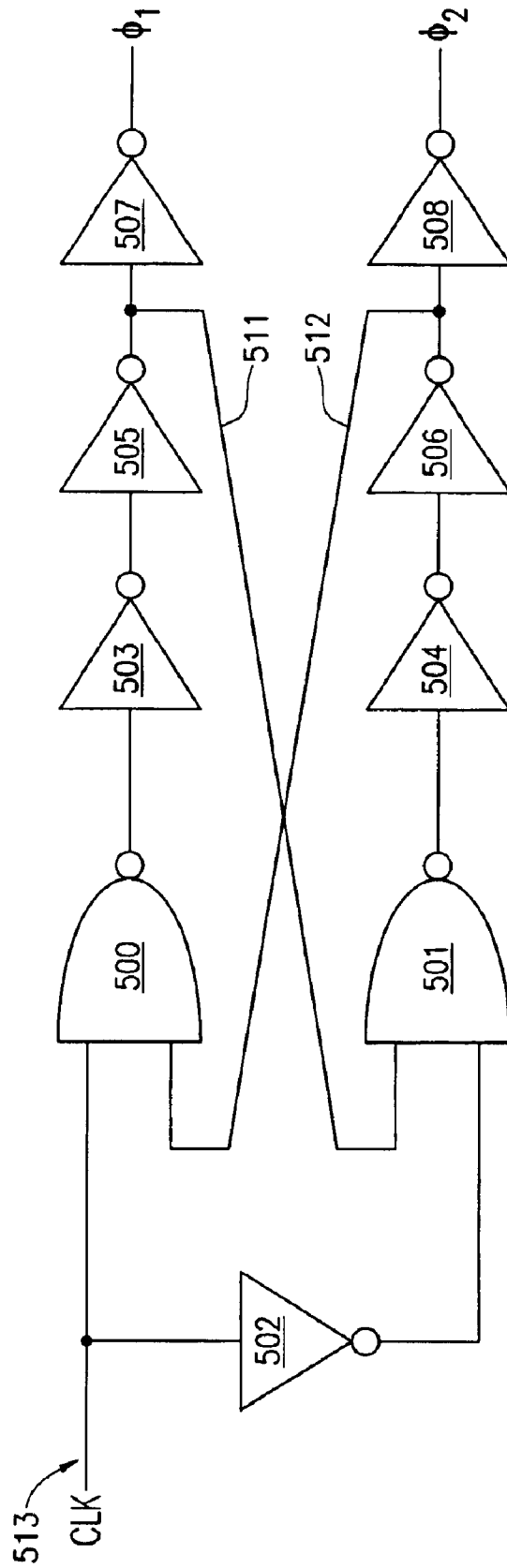

FIG. 2

510

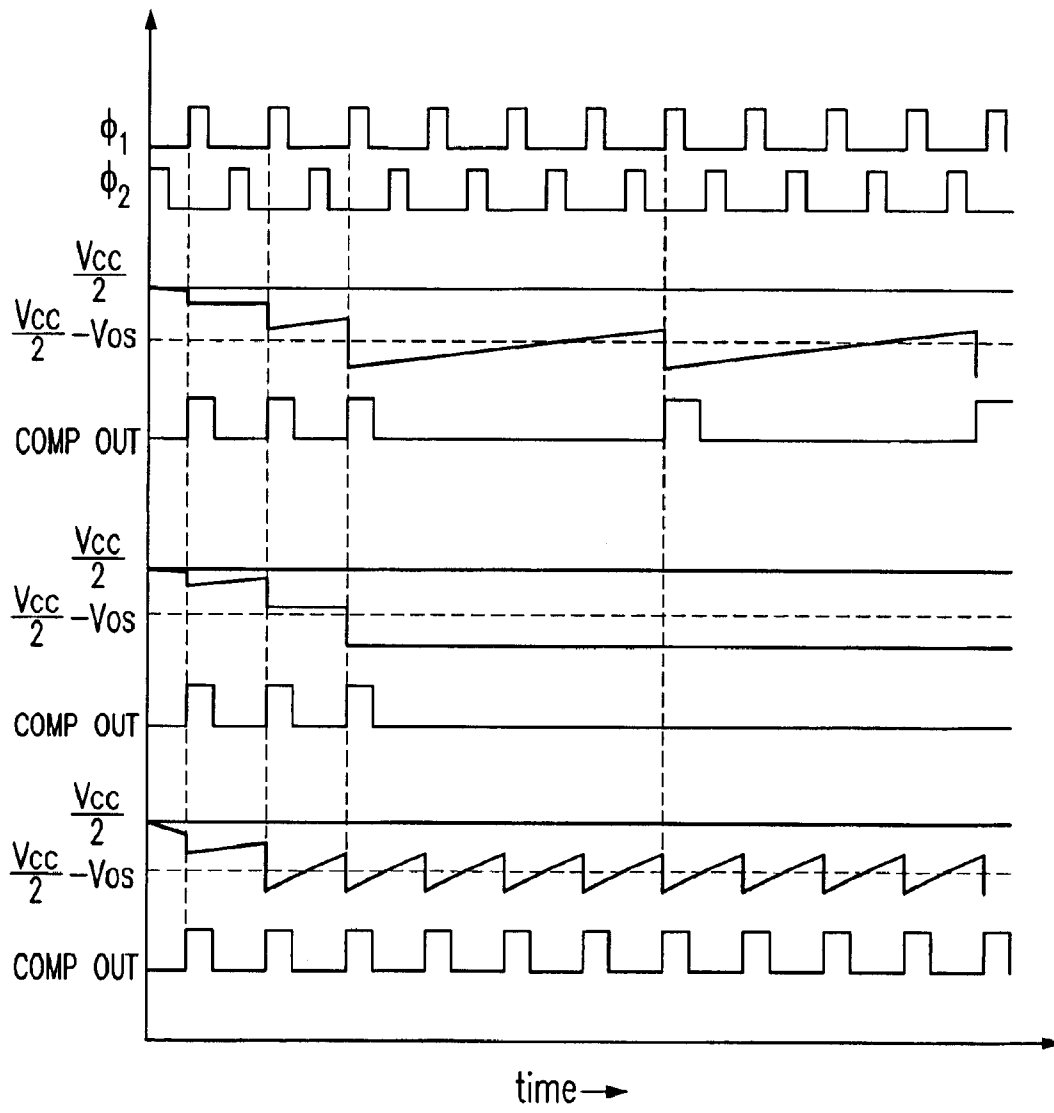
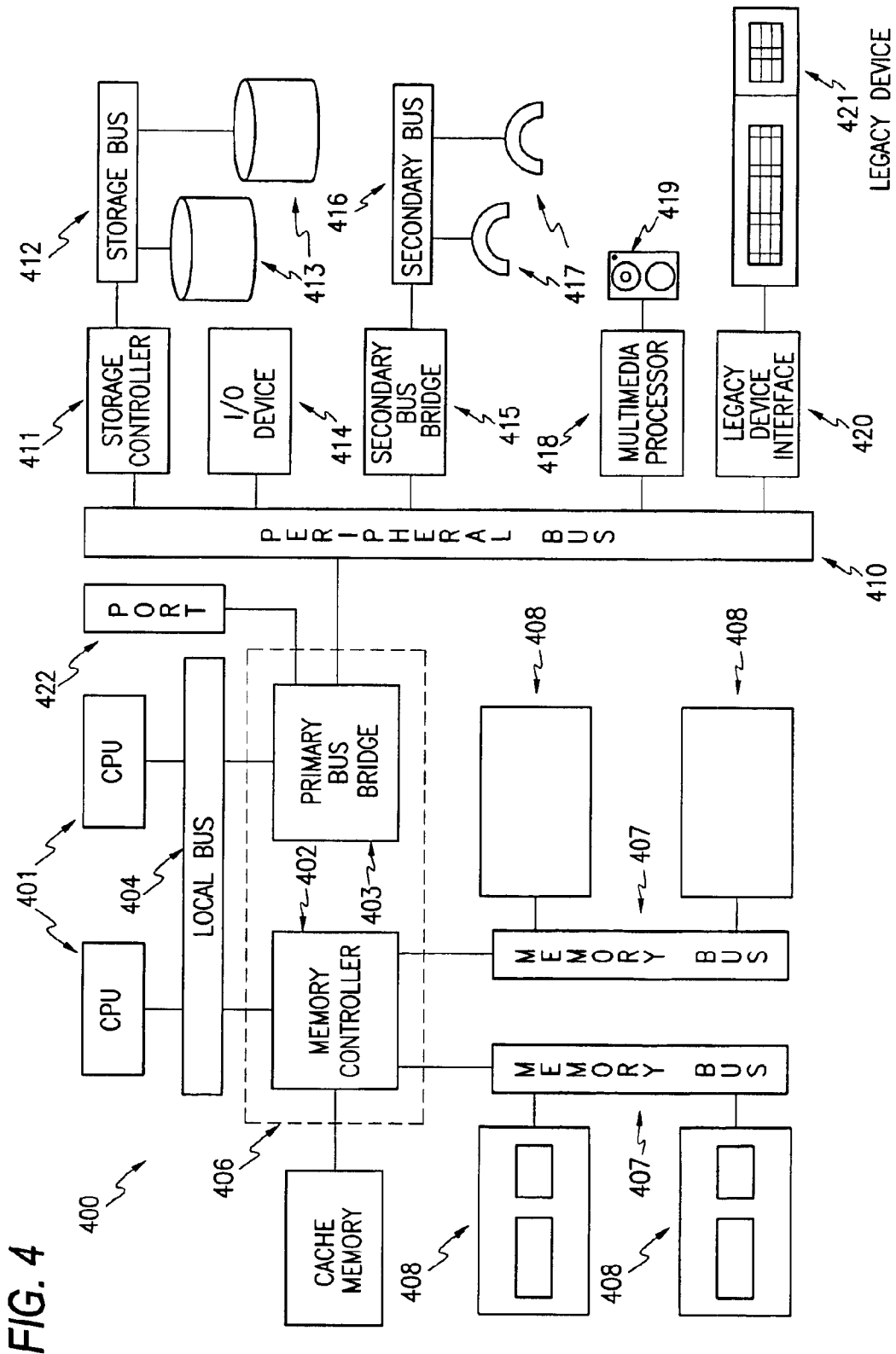

FIG. 3



INTEGRATED CHARGE SENSING SCHEME FOR RESISTIVE MEMORIES

FIELD OF THE INVENTION

The present invention relates to memory devices, and more specifically to an integrated charge sensing scheme for resistive memories.

BACKGROUND OF THE INVENTION

Digital memories are widely used in computers, computer system components and computer processing systems. Resistive memories store digital information in the form of bits or binary digits as "0"s or "1"s based on the resistance of a memory element or cell.

Resistive memory devices are configured in arrays where a resistive element or cell is at the intersection of a row line (word line) and a column line (digit line or bit line). In order to read or sense the state of a memory cell, it is necessary to first select the desired memory cell by selecting the column line and row line, which intersect at the desired memory element. Once the desired memory element is isolated, the selected memory cell is then read by applying a read voltage to the cell.

SUMMARY OF THE INVENTION

The present invention is directed towards an integrated charge sensing scheme for sensing the resistance of a resistive memory element. In accordance with an embodiment of the present invention, leakage current through the resistive memory element is used to charge a capacitor coupled to the digit or bit line. The voltage on the capacitor, which corresponds to the voltage on the digit line, is applied to a first input of a clocked comparator. When the voltage on the digit line exceeds a predetermined value (determined by a fixed voltage applied to a second input to the comparator and an offset built-into the comparator), and when a leading edge of a clock signal is received, the comparator switches to a high state and the charge is then drawn off from the capacitor until the voltage at the first input falls below that at the second input or a falling edge of the clock signal occurs. At that time, the comparator switches to a low state and voltage on the capacitor begins to build again. If on the next clock leading edge the voltage at the first input again exceeds that at the second input, the comparator again goes to a high state. If instead, the voltage on the first input is less than that of the second input, the clocked comparator continues its low output. The number of times that the clocked comparator switches to a high state over a fixed period of time can be counted to provide an indication of the leakage current, and thus the resistance, of the memory element.

BRIEF DESCRIPTION OF THE DRAWINGS

Other features and advantages of the present invention will become apparent when the following description is read in conjunction with the accompanying drawings, in which:

FIG. 1 is schematic diagram illustrating the integrated charge sensing circuit of an embodiment of the present invention coupled to an array of resistive memory cells;

FIG. 2 is an exemplary block diagram of a non-overlapping clock generation circuit used in the present invention;

FIG. 3 is a set of timing diagrams for the operation of the integrated charge sensing circuit of FIG. 1; and

FIG. 4 is an exemplary computer system using resistive memory devices including the integrated charge sensing circuit of the present invention.

DETAILED DESCRIPTION OF THE PREFERRED EMBODIMENTS

FIG. 1 shows the integrated charge sensing circuit of an embodiment of the present invention coupled to an array of resistive memory cells arranged at the intersection of column lines (digit lines) and row lines (word lines). Two exemplary memory cells **10a** and **10b** are shown. Memory cell **10a** is addressed by row line **15b** and digit line **20b**. Memory cell **10b** is addressed by row line **15c** and digit line **20b**. Memory cells **10a** and **10b** each include an access transistor **25** and a programmable resistance element **30** coupled to a voltage source of $V_{CC}/2$. In the following discussion, the circuit of the present invention is described with reference to exemplary memory cell **10a**. Although the invention is described below with respect to a resistive memory cell, e.g., resistive element **30** which is accessed with an access transistor **25**, the invention can also be adapted to work with other techniques for accessing the memory cell as long as current through a selected memory element is supplied to capacitor **75**.

In accordance with the present invention, digit lines **20a**, **20b**, **20c** and **20d** are: each connected to a respective integrated charge sensing circuit **35** such as the one shown connected to digit line **20b** through respective column select transistors such as **20b-1**. Measurement circuit **35** is formed of a feedback loop including a clocked comparator **40** for measuring the current leaked through memory cell **10a**, which is stored on a digit line capacitor **75**. Capacitor **75** is coupled to a first input of comparator **40**. Comparator **40** is provided with an internal offset voltage, V_{OS} at its second input, which also receives a reference voltage $V_{CC}/2$. In accordance with the operation of the circuit of the present invention, comparator **40** makes a comparison each time clock signal Φ_1 (shown in FIG. 3) goes high. At that time comparator **40** makes a comparison between the voltage on digit line **20b** and the reference input $(V_{CC}/2)-V_{OS}$. When the voltage on digit line **20b** exceeds $(V_{CC}/2)-V_{OS}$, the output of clocked comparator **40** switches high. The high output of comparator **40** closes switch **42** and causes the charge stored on digit line capacitor **75** to be drawn off/transferred onto another capacitor **45**. The high output of comparator **40** also opens switch **60**. When the voltage on the digit line falls below $(V_{CC}/2)-V_{OS}$, or clock signal Φ_1 goes low, the comparator **40** output goes low, opening switch **42** and closing switch **60** to draw any charge on capacitor **45** to ground. Each time clock signal Φ_1 goes high, another comparison is made. If, at the time of the comparison, the voltage on capacitor **75** is lower than that at the second input of comparator **40** then the output of comparator **40** remains low. The process of discharging and recharging capacitor **75** continues for a predetermined period of time. During this predetermined period of time a counter **65** is enabled and counts all low to high transitions of comparator **40**. The number of times comparator transitions from low to high during the predetermined time period is representative of a resistance of the memory element **30** or cell **10a**.

It is noted that digit lines have parasitic capacitance and can be charged by the current conducted through the memory cells and accordingly capacitor **75** may be a discrete capacitor, a parasitic capacitance of the digit line or a combination of the two. It is also noted that $V_{CC}/2$ at the memory cell and at the comparator are physically tied together. As noted, switch **60** is operated when the output of

comparator **40** goes low to draw charge on capacitor **45** to ground, thereby enabling capacitor **45** to again draw charge from capacitor **75** when switch **42** is closed. In an alternative embodiment, switch **60** may be operated by a complementary non-overlapping clock Φ_2 (shown in FIG. **3**) to clock signal Φ_1 (shown in FIG. **3**) being read.

The charging and discharging of capacitor **75** and selective discharging of capacitor **45** is implemented with switches **42** and **60** which, as shown in FIG. **1**, act together to either connect capacitor **45** to the digit line or alternatively to ground depending upon the output state of comparator **40** or the state of non-overlapping clock signal Φ_2 if used to control switch **60**. Those skilled in the art will appreciate, with the benefit of the present description, that the switching function can be implemented in numerous different circuits using, for example, transistors for switches **42** and **60**, and is not limited to the two switches illustrated.

The circuit of the present invention further includes the counter **65**, controlled by an enable "EN" signal during the read period, that counts the number of times N that comparator **40** goes low to high in a predetermined period of time. The count N is inversely proportional to the current and thus the resistance of the memory cell **10a**.

A digital value comparison is performed on the value N stored in counter **65** by a digital value comparison device **70** to determine at the end of the predetermined read period if the value N, and thus the resistance of memory cell **10a** is above or below a threshold value to determine if the resistance is above or below a predetermined value to indicate a logic one or a logic zero state.

In an exemplary embodiment of the present invention, the digital value comparison device could operate to evaluate the count N in the following manner. A high resistance value and a low resistance value of the resistive memory cell are known in a gross sense. Thus, for example, a high resistance value might be represented by a count (N value) of 10 and a low resistance value might be represented by a count of 20. Accordingly, a threshold value of 15 can be used by comparison device **70** to determine the logic state of the sensed memory cell.

FIG. **2** is an exemplary block diagram of a non-overlapping clock generator which may be used in the present invention to produce Φ_1 and Φ_2 clock signals, which are complementary and non-overlapping clock signals.

The oscillator clock output **513** is coupled to one terminal of NAND gate **500**. The oscillator clock output signal **513** is also inverted via logic inverter **502** and connected to one terminal of NAND gate **501**. The outputs of NAND gates **500** and **501** are each dually inverted via inverters **503**, **505** and **504**, **506**, respectively. The outputs **511** and **512** of the dual inverters (**503**, **505** and **504**, **506**) are each coupled to a respective inverter **507** and **508**, and are also fed back respectively to a second terminal of NAND gates **501** and **500**. Inverters **507** and **508** respectively output non-overlapping signals Φ_1 , and Φ_2 (shown in FIG. **3**).

FIG. **3** is a set of timing diagrams for the operation of the integrated charge sensing circuit of FIG. **1**. Φ_1 and Φ_2 (shown in FIG. **3**) are the two complementary and non-overlapping clock signals produced, for example, by the FIG. **2** circuit.

There are three distinct examples of the circuit operation depicted in FIG. **3**. In the bottommost example, the resistance in the memory cell is small. In this instance, digit line **20b** (bold line) is pulled quickly to $V_{CC}/2$ because there is very little resistance, which limits how fast digit line capacitor **75** charges. This causes comparator **40** output (COMP

OUT) to go high frequently resulting in digit line capacitor **75** pulling digit line **20b** low (towards ground). The comparator output (COMP OUT), therefore, mimics Φ_1 . If the resistance is very small, so low that digit line **20b** can never be pulled below the $V_{CC}/2 - V_{OS}$ threshold, then the output of comparator **40** will go high every time the comparator is clocked. In this instance, the effect is to constantly pull charge from the bit line.

In the middle example, the resistance in the memory cell is very large. In this instance, digit line **20b** is quickly pulled low to below $V_{CC}/2 - V_{OS}$. Because of the high resistance, the digit line charges very slowly back to $V_{CC}/2$, which causes comparator output (COMP OUT) to remain low most of the time.

In the topmost example, the resistance of the memory cell is in an intermediate range. Comparator **40** fires on the rising edge of Φ_1 and a comparison is made between digit line **20b** and $V_{CC}/2 - V_{OS}$. If digit line **20b** voltage is greater than $V_{CC}/2 - V_{OS}$, the output of comparator **40** (COMP OUT) goes high. If digit line **20b** voltage is less than $V_{CC}/2 - V_{OS}$, the output of comparator **40** (COMP OUT) remains low. The output of comparator **40** feeds clocked counter **65**. Comparator **40** fires on the rising edge of (<, as indicated by the dotted lines at the rising edge of Φ_1 on FIG. **3**). That is, at the rising edge of the first three pulses of Φ_1 , a comparison is made and the digit line is greater than $V_{CC}/2 - V_{OS}$. At the rising edge of each Φ_1 pulse, another comparison is made. After the first three COMP OUT pulses, and during the next three Φ_1 pulses, the voltage at the first input of comparator **40** is lower than the reference $V_{CC}/2 - V_{OS}$ so the COMP OUT remains low during this period. Finally, on the seventh Φ_1 pulse the bit line voltage on capacitor **75** is greater than the reference $V_{CC}/2 - V_{OS}$ and another pulse is produced at COMP OUT.

It is noted, in all instances, a comparator output of one/high allows the digit line capacitance **75** to discharge resulting in a voltage drop. The resistance of the memory cell then pulls the digit line voltage back up towards $V_{CC}/2$. In the bottommost example/trace, the voltage gets pulled back above $V_{CC}/2 - V_{OS}$ quickly. In the middle example/trace, the resistance is so great that it takes a very long time to pull the voltage up over the threshold level/value. In all examples, counter **65** counts on the leading edge of the COMP OUT pulses during the predetermined read period to register a value representing the resistance of memory cell **30**.

Although FIG. **3** shows operation of the FIG. **1** circuit for three exemplary resistance values, in most digital circuits only two resistance states are stored in the memory cells.

FIG. **4** illustrates an exemplary processing system **400** which uses a resistive memory device comprising an integrated charge sensing circuit in accordance with the embodiments of the present invention disclosed above in connection with FIGS. **1-3**. The processing system **400** includes one or more processors **401** coupled to a local bus **404**. A memory controller **402** and a primary bus bridge **403** are also coupled to the local bus **404**. The processing system **400** may include multiple memory controllers **402** and/or multiple primary bus bridges **403**. The memory controller **402** and the primary bus bridge **403** may be integrated as a single device **406**.

The memory controller **402** is also coupled to one or more memory buses **407**. Each memory bus accepts circuits such as, a resistive memory device **408** which include at least one circuit using the integrated charge sensing circuit of the present invention. The resistive memory device **408** may be integrated with a memory card or a memory module and a

5

CPU. Examples of memory modules include single inline memory modules (SIMMs) and dual inline memory modules (DIMMs). The memory controller 402 may also be coupled to a cache memory 405. The cache memory 405 may be the only cache memory in the processing system. Alternatively, other devices, for example, processors 401 may also include cache memories, which may form a cache hierarchy with cache memory 405. If the processing system 400 include peripherals or controllers which are bus masters or which support direct memory access (DMA), the memory controller 402 may implement a cache coherency protocol. If the memory controller 402 is coupled to a plurality of memory buses 407, each memory bus 407 may be operated in parallel, or different address ranges may be mapped to different memory buses 407.

The primary bus bridge 403 is coupled to at least one peripheral bus 410. Various devices, such as peripherals or additional bus bridges may be coupled to die peripheral bus 410. These devices may include a storage controller 411, a miscellaneous I/O device 414, a secondary bus bridge 415, a multimedia processor 418, and an legacy device interface 420. The primary bus bridge 403 may also coupled to one or more special purpose high speed ports 422. In a personal computer, for example, the special purpose port might be the Accelerated Graphics Port (AGP), used to couple a high performance video card to the processing system 400.

The storage controller 411 couples one or more storage devices 413, via a storage bus 412, to the peripheral bus 410. For example, the storage controller 411 may be a SCSI controller and storage devices 413 may be SCSI discs. The I/O device 414 may be any sort of peripheral. For example, the I/O device 414 may be an local area network interface, such as an Ethernet card. The secondary bus bridge 415 may be used to interface additional devices via another bus to the processing system. For example, the secondary bus bridge 415 may be an universal serial port (USB) controller used to couple USB devices 417 via to the processing system 400. The multimedia processor 418 may be a sound card, a video capture card, or any other type of media interface, which may also be coupled to one additional devices such as speakers 419. The legacy device interface 420 is used to couple legacy devices 421, for example, older styled keyboards and mice, to the processing system 400.

The processing system 400 illustrated in FIG. 4 is only an exemplary processing system with which the invention may be used. While FIG. 4 illustrates a processing architecture especially suitable for a general purpose computer, such as a personal computer or a workstation, it should be recognized that well known modifications can be made to configure the processing system 400 to become more suitable for use in a variety of applications. For example, many electronic devices which require processing may be implemented using a simpler architecture which relies on a CPU 401 coupled to resistive memory device 408 and/or memory buffer devices 404.

While the invention has been described and illustrated with reference to specific exemplary embodiments, it should be understood that many modifications and substitutions can be made without departing from the spirit and scope of the invention. Accordingly, the invention is not to be considered as limited by the foregoing description but is only limited by the scope of the appended claims.

What is claimed as new and desired to be protected by Letters Patent of the United States is:

1. An integrated charge sensing circuit for a resistive memory device comprising:

a digit line coupled to a first capacitor;

6

a comparator coupled to said digit line for determining if a voltage on said digit line has exceeded a predetermined threshold voltage level, said comparator having an output which switches between a first state when said voltage on said first capacitor exceeds said predetermined threshold voltage level and a second state when said voltage on said first capacitor is less than said predetermined threshold voltage level;

a second capacitor which is alternately connected and disconnected from said digit line based upon said output of said comparator, said second capacitor being connected to said digit line when said output of said comparator is in said first state, said second capacitor being disconnected from said digit line when said output of said comparator is in a second state; and

a counter for counting a number of times said comparator switches to said first state.

2. The integrated charge sensing circuit according to claim 1, further comprising a digital comparison circuit for comparing said count in said counter to a predetermined value.

3. The integrated charge sensing circuit according to claim 1, wherein said predetermined threshold voltage level is approximately $V_{CC}/2 - V_{OS}$, where V_{CC} is a supply voltage and V_{OS} is an offset voltage at a reference voltage input of said comparator.

4. The integrated charge sensing circuit of claim 1, further comprising a first switch for alternately connecting and disconnecting the digit line from said second capacitor based upon said output of said comparator.

5. The integrated charge sensing circuit of claim 1, further comprising a second switch for discharging said second capacitor when said second capacitor is disconnected from said digit line.

6. The integrated charge sensing circuit of claim 1, wherein said comparator is clocked and performs a comparison in response to a transition in said clock signal.

7. The integrated charge sensing circuit of claim 1, wherein said first capacitor is a discrete capacitor.

8. The integrated charge sensing circuit of claim 1, wherein said first capacitor is a parasitic capacitance of said digit line.

9. The integrated charge sensing circuit of claim 1, wherein said first capacitor is both a discrete capacitor and a parasitic capacitance of said digit line.

10. The integrated charge sensing circuit of claim 1, wherein said output of said comparator is in said first state in response to a first input being greater than a reference voltage input at the time of occurrence of a first clock signal transition, and said output of said comparator in said second state in response to said first input being less than said reference voltage input at the time of occurrence of said first clock signal transition.

11. The integrated charge sensing circuit of claim 10, wherein said output of said comparator is in said second state in response to a second clock signal transition.

12. The integrated charge sensing circuit of claim 1, wherein a supply voltage is applied to a memory cell of said resistive memory device and said supply voltage is further applied to a reference voltage input of said comparator.

13. The integrated charge sensing circuit of claim 1, wherein said memory device comprises a memory cell connected to an access transistor.

14. An integrated charge sensing circuit for a resistive memory device comprising:

a digit line including a first capacitor to be charged by current leaked through a resistive memory cell during operation;

7

a first circuit for measuring a voltage on said first capacitor and switching between a first state when said voltage on said digit line capacitor exceeds a predetermined threshold voltage level and a second state when said voltage on said first capacitor is less than said predetermined threshold voltage level; and

a counter for counting a number of times said first circuit is in one of said first state and said second state within a predetermined period of time.

15. The integrated charge sensing circuit according to claim **14**, further comprising a digital comparison circuit for comparing a count in said counter to a predetermined value to determine a logic state of said memory cell.

16. The integrated charge sensing circuit according to claim **14**, wherein said first circuit includes a comparator for comparing the voltage on said first capacitor to said predetermined threshold voltage level.

17. The integrated charge sensing circuit according to claim **16**, wherein said predetermined threshold voltage level is approximately $V_{CC}/2 - V_{OS}$, where V_{CC} is a supply voltage and V_{OS} is an offset voltage at a reference voltage input of said comparator.

18. The integrated charge sensing circuit of claim **16**, further comprising a first switch for alternately connecting and disconnecting a second capacitor to said digit line for discharging said first capacitor based upon an output of said comparator and a second switch for discharging said second capacitor when said second capacitor is disconnected from said digit line.

19. The integrated charge sensing circuit of claim **16**, wherein said comparator is clocked and performs a comparison in response to a clock signal going to a first states.

20. The integrated charge sensing circuit of claim **14**, wherein said first capacitor is a discrete capacitor.

21. The integrated charge sensing circuit of claim **14**, wherein said first capacitor is a parasitic capacitance of said digit line.

22. The integrated charge sensing circuit of claim **14**, wherein said first capacitor is both a discrete capacitor and a parasitic capacitance of said digit line,.

23. The integrated charge sensing circuit of claim **19**, wherein said output of said comparator is high in response to a first input being greater than a reference voltage input when said clock signal goes to said first state and said output of said comparator is low in response to said first input being less than said reference voltage input when said clock signal goes to said first state.

24. The integrated charge sensing circuit of claim **23**, wherein said output of said comparator goes low when said clock signal goes to a second state.

25. The integrated charge sensing circuit of claim **14**, wherein a supply voltage is applied to a memory cell of said resistive memory device and said supply voltage is further applied to a reference voltage input of said comparator.

26. The integrated charge sensing circuit of claim **14**, wherein said resistive memory cell is coupled by an access transistor to a word line and a column line.

27. A computer system comprising:

a processor; and

a resistive memory device coupled to said processor via a bus, said resistive memory device including a memory cell and an integrated charge sensing circuit for said memory cell, said integrated charge sensing circuit comprising:

8

a digit line including a first capacitor to be charged by current passing through said resistive memory cell during a read operation;

a circuit for measuring a voltage on said first capacitor and switching between a first state when said voltage on said first capacitor exceeds a predetermined threshold voltage level and a second state when said voltage on said first capacitor is less than said predetermined threshold voltage level; and

a counter for counting a number of times said circuit is in one of said first state and said second state within a predetermined period of time.

28. A resistive memory device comprising:

an integrated charge sensing circuit, said integrated charge sensing circuit comprising:

a digit line including a first capacitor to be charged by current passing through a resistive memory cell during a read operation;

a circuit for measuring a voltage on said first capacitor and switching between a first state when said voltage on said first capacitor exceeds a predetermined threshold voltage level and a second state when said voltage on said first capacitor is less than said predetermined threshold voltage level; and

a counter for counting a number of times said circuit is in one of said first state and said second state within a predetermined period of times.

29. A read circuit for reading a resistive memory cell, said circuit comprising:

a access transistor for causing a current to pass through said memory cell to a digit line during a read operation;

a first capacitor coupled to said digit line for charging up a voltage on said digit line in response to said current;

a clocked comparator having a first input coupled to said digit line and a second input for receiving a reference voltage, said comparator making a comparison of voltage levels at said first and second inputs in response to a first state of a first clock signal and providing a first output state if said digit line voltage is greater than said reference voltage and a second output state if said reference voltage is greater than said digit line voltage;

a second capacitor;

a first switch element responsive to said first state of said comparator for coupling said second capacitor to said digit line to reduce the voltage on said digit line and being responsive to said second state of said comparator for uncoupling said second capacitor from said digit line.

30. A read circuit of claim **29** further comprising a counter for counting the number of times said comparator circuit is in one of said first and second states during a predetermined time period.

31. The read circuit of claim **29** wherein said comparator moves to said second output state in response to a second state of said first clock signal.

32. The read circuit of claim **29** wherein said second switch is controlled by the output state of said comparator.

33. The read circuit of claim **29** wherein said second switch is controlled by a first state of a second clock signal, said second clock signal having pulses which are interleaved in time with respect to pulses of said first clock signal.

* * * * *

UNITED STATES PATENT AND TRADEMARK OFFICE
CERTIFICATE OF CORRECTION

PATENT NO. : 6,870,784 B2
DATED : March 22, 2005
INVENTOR(S) : R.J. Baker

Page 1 of 1

It is certified that error appears in the above-identified patent and that said Letters Patent is hereby corrected as shown below:

Column 4,

Line 23, “(<,” should read -- Φ_1 --;
Line 64, “include” should read -- includes --;

Column 5,

Line 9, “include” should read -- includes --;
Line 18, “die” should read -- the --;
Lines 21, 32 and 36, “an” should read -- a --;
Line 22, “also coupled” should read -- also be coupled --;
Line 40, “one additional” should read -- one of such additional --;
Line 40, “such” should read -- [delete] --.

Column 7,

Line 32, “states” should read -- state --;

Column 8,

Line 31, “a” should read -- an --.

Signed and Sealed this

Ninth Day of August, 2005

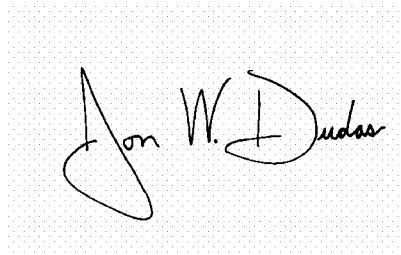
A handwritten signature in black ink on a light gray dotted background. The signature reads "Jon W. Dudas" in a cursive style.

JON W. DUDAS
Director of the United States Patent and Trademark Office