

A Highly Efficient and Reliable Electrowetting on Dielectric Device for Point-of-Care Diagnostics

Yiyan Li, R. Jacob Baker

Department of Electrical and Computer Engineering
University of Nevada, Las Vegas
Las Vegas, NV 89154-4026, USA
liy10@unlv.nevada.edu

Dominic Raad

Kisco Conformal Coating, LLC
San Jose, CA 95119, USA
draad@kiscoparylene.com

Abstract— A highly efficient and reliable electrowetting on dielectric (EWOD) digital microfluidics (DMF) chip is proposed. An 8 μm parylene C layer is used as the dielectric material. Extra vapor-phase silane (VPS) is introduced into the chamber and acts as an aerosol primer to enhance the chemical adhesion to the parylene C surface. The EWOD chip can perform droplet dispensing, merging and splitting smoothly in an air ambient. Dual electrode dispensing mode (DEDM) and single electrode dispensing mode (SEDM) are tested to investigate the dispensing volume accuracy. Small deviations (0.0467 μL for DEDM and 0.0303 μL for SEDM) are observed for the dispensing. Droplets from 1.5 μL to 2.3 μL are tested for the minimum splitting voltage. Larger droplets require larger voltages to be split. The proposed EWOD chip is promising for future point-of-care clinical diagnostics.

Keywords—*electrowetting; droplet splitting; droplet dispensing; digital microfluidics*

I. INTRODUCTION

Microfluidics is a multidisciplinary area that has been rapidly developing since the beginning of the 1980s. The most successful commercial application of microfluidics is inkjet printers [1]. Also, in scientific research, microfluidics has been used for immunoassay preparation [2,3], protein depletion [4], DNA amplification [5] and any fluidic microelectromechanical systems [6]. There are mainly two sub-areas in microfluidics, one is continuous microfluidics [7], which is usually controlled by an external pump and transports fluids continuously within capillary tubes; the other one is digital microfluidics (DMF) [8-10], which is able to deliver discrete micro droplets and manipulate droplet behaviors (mixing, actuating and splitting) by digital microcontrollers. Things became easier and more attractive when the microfluidic chip was interfaced with digital devices. By using microcontrollers or FPGAs (field-programmable gate array), DMF can manipulate a large array of droplets in parallel, which is critical for high throughput microfluidic experiments. With the advances in microelectronics, all DMF controlling and driving devices can fit into a portable box [11]. In DMF, one of the main physical and mechanical principles of moving a droplet on a surface is EWOD. EWOD describes a configuration in which an insulating layer separates the working liquid and actuation electrodes. PCB (printed circuit board) EWOD chips are low cost and easy to fabricate, but the driving voltage is high and oil environment is required for a smooth actuation [12-14].

A reliable EWOD DMF chip with an 8 μm parylene C dielectric layer is proposed in this study (Fig. 1). Droplet dispensing, merging and splitting are tested under various droplet volumes. The droplet dispensing accuracy and splitting minimum voltages are discussed.

II. MATERIALS AND METHODS

A. EWOD chip fabrication

Devices were fabricated in the cleanroom facility of Nevada Nanotechnology Center at University of Nevada, Las Vegas. The fabrication reagents includes Schott Boro Float glass substrate with Chrome coated (100 nm) microfluidic blank slides (with positive photoresist coated, Telic, Valencia, CA, USA), Teflon-AF solution (amorphous fluoroplastic resin in solution, 400S2-100-1, DuPont, Mississauga, ON, CA), photoresist developer RD6 (Futurrex, INC., Franklin, NJ, USA), Chromium etchant (Sigma-Aldrich, Co., MO, USA), photoresist remover (Microposit Remover 1165, Rohm and Haas Electronic Materials LLC, MA, USA), indium tin oxide (ITO) coated glass (Adafruit INC., NYC, USA). Open source integrated circuit (IC) layout tools Electric VLSI [15] is used to pattern the mask of the electrode array. GDSII output files from Electric VLSI are sent to Infinite Graphics INC. (MN, USA) for plotting (25,000 dpi). The top plate gap height is controlled by a PZT plate [16].

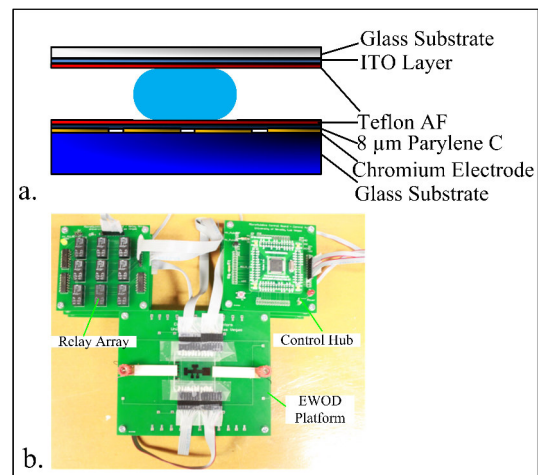

Fig. 1 The EWOD chip fabrication layers (a) and the EWOD system (b).

In order to make the surface more robust for higher voltages, an 8 μm parylene C is coated to the EWOD chip with a chemical adhesion process. The parylene C coating is conducted at Kisco Conformal Coating, LLC (San Jose, CA, USA). 250 nm Teflon AF is spin coated to the EWOD chip and the top plate surface. DI water droplets are used as the testing liquid for the experiments.

B. EWOD DMF control system

A high-voltage module (EMCO F40, EMCO, Schweiz, Switzerland) is used for the high voltage supply. A high-voltage square wave (1 kHz to 10 kHz) is created at the drain of the NMOS transistors (VN2460) seen below in Fig. 2. The gate is connected to the I/O ports of the microcontroller. For example, if the gate goes high then the drain goes low. If the gate goes low then the drain is pulled to the high DC voltage through a resistor.

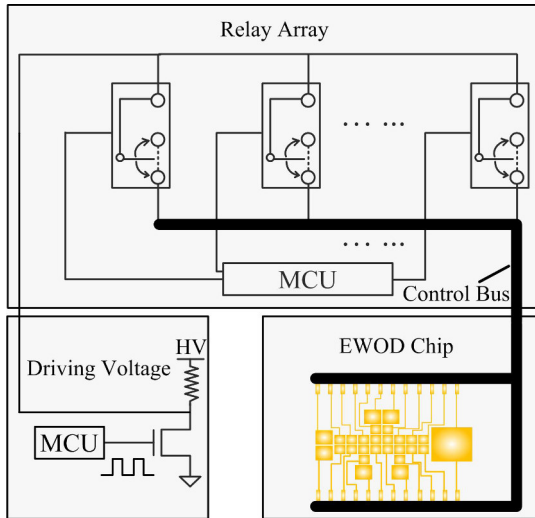

Fig. 2 The EWOD chip and the control system.

There are 27 electrodes on the EWOD chip, so 27 relays are needed as the switches for the electrodes. The high voltage pulses are connected to the input of the relay array. A MCU is used to turn on/off the electrodes; then the high voltage sources will be delivered or blocked by the relay. The other electrodes that do not need to be activated are floating (turned off the electrode by disconnecting the relay).

The driving pulse train of the two neighbor electrodes (Fig. 3) have an overlapping area. The receding electrode is still turned on for a while after the forwarding electrode has been turned on. The purpose is to keep the droplet in a big footprint area while the forwarding electrode is trying to drag it forward. If the droplet is moving slowly, then the overlapping area (in time) should be larger to wait for the droplet to travel through the receding electrode. Otherwise the droplet will miss the opportunity to be actuated by the forwarding electrode. The droplet velocity has big differences with different droplet volumes and different gap heights.

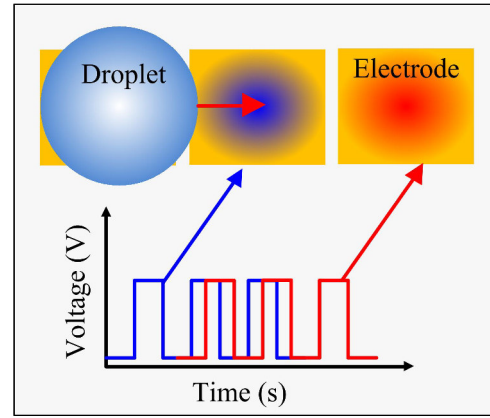

Fig. 3 EWOD electrode driving voltages. The DC pulses have an overlapping area for a more reliable actuation.

III. RESULTS AND DISCUSSIONS

A. Droplet dispensing

Dispensing is the first step of the on-chip experiments. A smaller working droplet is generated from a larger electrode which is a reservoir of the chemical liquid. The forwarding electrode should be activated first to drag a certain amount of liquid from the reservoir. While the size of the generated droplet becomes close to the desired volume, the electrodes in the middle of the reservoir and the targeting electrode are turned off to disconnect the dispensed droplet from the reservoir (Fig. 4).

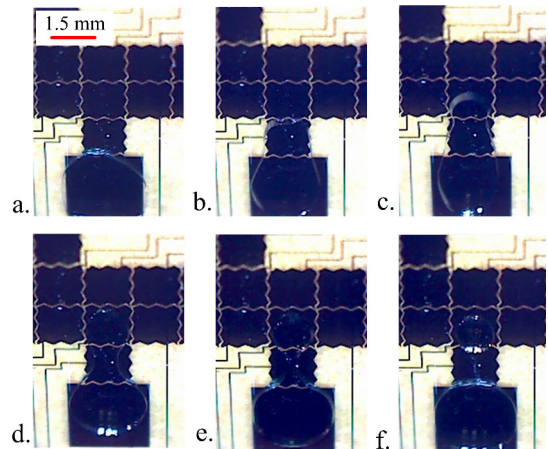

Fig. 4 The process of droplet dispensing from the reservoir.

The biggest issue with EWOD dispensing is the volume control. The dispensed droplet volume is hard to be controlled accurately. Adding capacitive sensors to a feedback control loop to manipulate the dispensed droplet volume in real time can improve the volume accuracy [17]. But the droplet-electrode capacitive data is influenced by the droplet position substantially [14].

Dual electrode dispensing mode (DEDM) and single electrode dispensing mode (SEDM) are tested (Fig. 5 and 6). The droplet volume is calculated by multiplying the footprint area (calculated by ImageJ) by the gap height (200 μm).

SEDM has a higher accuracy than DEDM. The standard deviations are $0.0467 \mu\text{L}$ for DEDM and $0.0303 \mu\text{L}$ for SEDM.

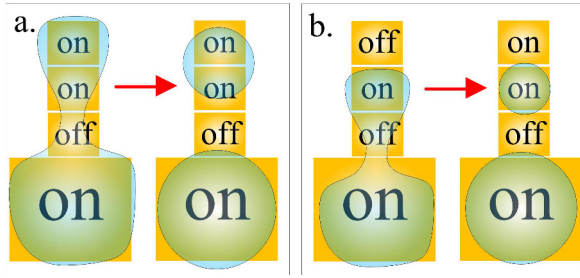

Fig. 5 Dual electrode dispensing mode (DEDM) (a) and single electrode dispensing mode (SEDM) (b).

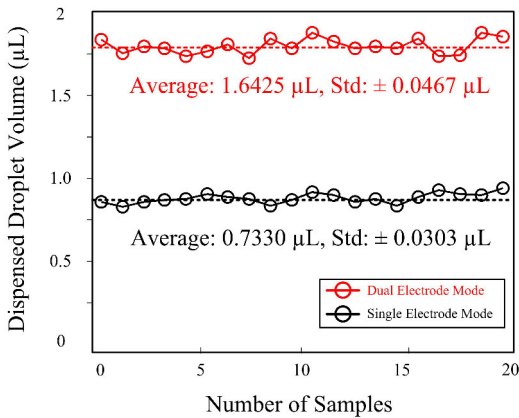

Fig. 6 Droplet dispensing accuracy.

Since the droplet volume affects the droplet actuation efficiency, when the dispensing is in process, the daughter droplets are much smaller than the reservoir. Varying the gap height [18] can accommodate the optimized gap height of smaller droplets.

B. Droplet merging

Mixing & merging two droplets are used for on-chip chemical reactions or dilutions. The purpose of on-chip mixing is to implement the conventional bench mixers used in biological labs. Mechanical shaking for a good chemical mix is not possible for the EWOD chip; so the merged droplets need to travel back and forth between two or three electrodes to insure the mix or reaction of the chemicals are completed. The droplet merging is fast, but the time spent on a sufficient mixing or reaction depends on the liquid types. Also gap height control and droplet movement control have been investigated for optimized mixing protocols [18,19]. It only takes less than 40 ms (after the droplets contacted with each other) to complete the droplet merging process in Fig. 7.

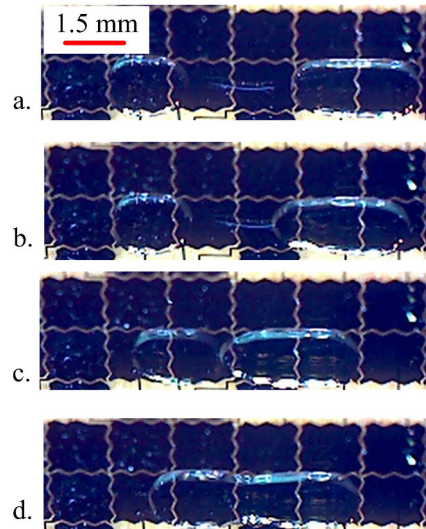

Fig. 7 Process of droplet merging.

C. Droplet splitting

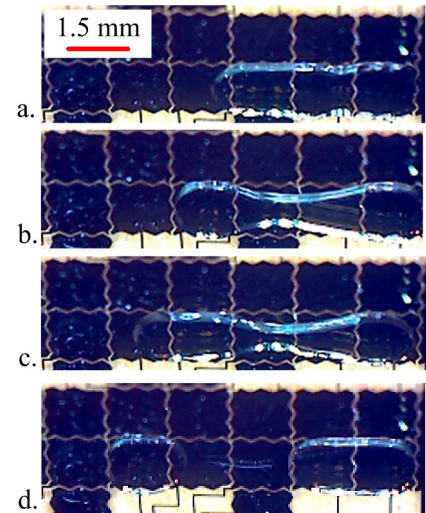

Fig. 8 Process of droplet splitting.

While doing the splitting experiment, the droplet is stretched by the electrodes at both the left and the right ends of the droplet. And then all the electrodes in the middle are turned off (Fig. 8). When the necking [20] appears, the droplet is further stretched resulting in two sister droplets. However there is one problem of open loop splitting. The electrodes at the two ends are competing against each other strength to drag the droplet to their side. When the activated electrodes are driven by the same voltage, the larger footprint area (the position) of the droplet will get more electrostatic force by the electrode underneath. In this case, unsymmetrical splitting may happen. So the success of splitting also depends on the initial position of the droplet. The same as dispensing, fast feedback capacitive sensing or an image processing controlled system may help balance the droplet position during the splitting experiment.

Larger droplets require larger splitting voltages. Splitting a 2.3 μL droplet needs 45 V more than splitting a 1.5 μL droplet (Fig. 9). The largest deviation on the minimum splitting voltage is 12.09 V occurs at the 1.5 μL droplet which shows a good repeatability of the tests.

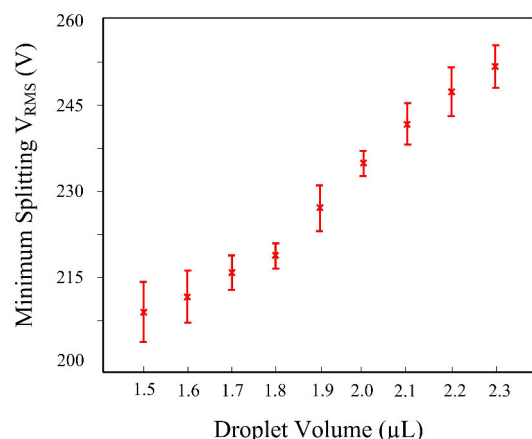

Fig. 9 Minimum splitting V_{RMS} for different sizes of droplets.

IV. CONCLUSION

An efficient and reliable EWOD DMF chip is proposed in this study. During the dielectric layer coating process, extra vapor-phase silane (VPS) is introduced into the chamber and acts as an aerosol primer to enhance the chemical adhesion to the parylene C surface. The parylene C layer is robust and has a high break down voltage (more than 600 V). With the robust dielectric layer and the hydrophobic surface, all the droplet operations are conducted in an air ambient. Without using conventional oil filler, the EWOD chip is compatible with more chemical reactions.

The EWOD chip can perform droplet dispensing, merging and splitting. DEDM and SEDM are tested for the dispensing volume accuracy. Small deviations (0.0467 μL for DEDM and 0.0303 μL for SEDM) are observed using the dispensing operation with the EWOD chip. A lower desired droplet volume can be dispensed more accurately by the chip. Minimum splitting voltages are tested for various droplet volumes. Larger droplets require larger splitting voltages. Splitting a 2.3 μL droplet needs 45 V more than splitting a 1.5 μL droplet.

A simplified EWOD electrode driving circuit is introduced to avoid bench instrumentations. The proposed

EWOD DMF chip is promising for future point-of-care clinical diagnostics.

REFERENCES

- [1] Ink-jet printers zoom into the office market, *New Scientist*. 480 (1979).
- [2] A.H. Ng, M. Lee, K. Choi, A.T. Fischer, J.M. Robinson, A.R. Wheeler, Digital microfluidic platform for the detection of rubella infection and immunity: a proof of concept, *Clin. Chem.* 61 (2015) 420-429.
- [3] M.H. Shamsi, K. Choi, A.H. Ng, A.R. Wheeler, A digital microfluidic electrochemical immunoassay, *Lab on a Chip*. 14 (2014) 547-554.
- [4] N. Mei, B. Seale, A.H. Ng, A.R. Wheeler, R. Oleschuk, Digital Microfluidic Platform for Human Plasma Protein Depletion, *Anal. Chem.* 86 (2014) 8466-8472.
- [5] C. Zhang, J. Xu, W. Ma, W. Zheng, PCR microfluidic devices for DNA amplification, *Biotechnol. Adv.* 24 (2006) 243-284.
- [6] R. Truckenmüller, S. Giselbrecht, N. Rivron, E. Gottwald, V. Saile, A. Van den Berg, M. Wessling, C. Van Blitterswijk, Thermoforming of Film Based Biomedical Microdevices, *Adv Mater.* 23 (2011) 1311-1329.
- [7] S.S. Kuntaegowdanahalli, A.A.S. Bhagat, G. Kumar, I. Papautsky, Inertial microfluidics for continuous particle separation in spiral microchannels, *Lab on a Chip*. 9 (2009) 2973-2980.
- [8] R.B. Fair, Digital microfluidics: is a true lab-on-a-chip possible? *Microfluidics and Nanofluidics*. 3 (2007) 245-281.
- [9] I. Barbulovic-Nad, H. Yang, P.S. Park, A.R. Wheeler, Digital microfluidics for cell-based assays, *Lab on a Chip*. 8 (2008) 519-526.
- [10] A.R. Wheeler, H. Moon, C.A. Bird, R.R. Ogorzalek Loo, C. Kim, J.A. Loo, R.L. Garrell, Digital microfluidics with in-line sample purification for proteomics analyses with MALDI-MS, *Anal. Chem.* 77 (2005) 534-540.
- [11] R. Fobel, C. Fobel, A.R. Wheeler, DropBot: An open-source digital microfluidic control system with precise control of electrostatic driving force and instantaneous drop velocity measurement, *Appl. Phys. Lett.* 102 (2013) 193513.
- [12] Y. Li, H. Li, R.J. Baker, A low-cost and high-resolution droplet position detector for an intelligent electrowetting on dielectric device, *Journal of Laboratory Automation*. 1 (2015) 1-7.
- [13] Y. Li, R. Chen, R.J. Baker, A fast fabricating electro-wetting platform to implement large droplet manipulation, 2014 IEEE 57th International Midwest Symposium on Circuits and Systems (2014) 326-329.
- [14] Y. Li, H. Li, R.J. Baker, Volume and concentration identification by using an electrowetting on dielectric device, 2014 IEEE Dallas Circuits and Systems Conferences (2014) 1-4.
- [15] <http://cmosedu.com/cmos1/electric/electric.htm>.
- [16] Y. Li, R.J. Baker, Computer vision assisted measurement of the displacements of a bimorph piezoelectric cantilever beam, *IEEE Biomedical Circuits and Systems Conference* (2015) 1-4.
- [17] J. Gong, All-electronic droplet generation on-chip with real-time feedback control for EWOD digital microfluidics, *Lab on a Chip*. 8 (2008) 898-906.
- [18] M. Yafia, H. Najjaran, High precision control of gap height for enhancing principal digital microfluidics operations, *Sensors Actuators B: Chem.* 186 (2013) 343-352.
- [19] P. Paik, V.K. Pamula, R.B. Fair, Rapid droplet mixers for digital microfluidic systems, *Lab on a Chip*. 3 (2003) 253-259.
- [20] S.K. Cho, H. Moon, C. Kim, Creating, transporting, cutting, and merging liquid droplets by electrowetting-based actuation for digital microfluidic circuits, *Microelectromechanical Systems, Journal of.* 12 (2003) 70-80.