

UNITED STATES PATENT AND TRADEMARK OFFICE

---

BEFORE THE PATENT TRIAL AND APPEAL BOARD

---

ams AG, AMS-TAOS USA INC.,  
SAMSUNG ELECTRONICS AMERICA, INC., and  
SAMSUNG ELECTRONICS CO. LTD.,  
Petitioners

v.

JJL TECHNOLOGIES LLC and 511 INNOVATIONS, INC.,  
Patent Owner

---

Case IPR2016-01793  
U.S. Patent No. 7,397,541

---

**PETITION FOR *INTER PARTES* REVIEW**

## TABLE OF CONTENTS

EXHIBIT LIST .....	v
I. MANDATORY NOTICES .....	1
A. Real Parties-in-Interest .....	1
B. Related Matters.....	1
C. Counsel.....	2
D. Service Information.....	2
E. Certification of Standing .....	2
II. OVERVIEW OF CHALLENGE AND RELIEF REQUESTED.....	3
III. THE '541 PATENT.....	3
A. Overview of the '541 Patent.....	3
B. Admitted Prior Art.....	7
IV. ORDINARY SKILL IN THE ART.....	7
V. CLAIM CONSTRUCTION .....	8
VI. GROUND 1: Claims 1, 3 and 11 of the '541 Patent are obvious over Farrar in view of O'Rourke.....	8
A. Overview of Farrar .....	8
B. Overview of O'Rourke.....	13
C. Farrar in view of O'Rourke Render Claims 1, 3 and 11 Obvious .....	14

1.	Claim 1:.....	14
2.	Claim 3 .....	19
3.	Claim 11 .....	20
D.	Charts.....	20
VII.	GROUND 2: Claims 1, 3 and 11 of the '541 Patent are obvious over JP	
	'028.....	24
A.	Overview of JP '028.....	24
B.	JP '028 Renders Claims 1, 3 and 11 Obvious.....	29
1.	Claim 1 .....	29
2.	Claim 3:.....	35
3.	Claim 11 .....	36
C.	Charts.....	38
VIII.	GROUND 3: Claims 1, 3 and 11 of the '541 Patent are obvious over	
	Mills.....	41
A.	Overview of Mills .....	41
B.	Mills Renders Claims 1, 3 and 11 Obvious.....	42
1.	Claim 1 .....	42
2.	Claim 3:.....	47

3.	Claim 11:.....	48
C.	Charts.....	48
IX.	NO EVIDENCE OF SECONDARY INDICIA OF NON- OBVIOUSNESS.....	<b>Error! Bookmark not defined.</b>
X.	CONCLUSION.....	51

## TABLE OF AUTHORITIES

	<b>Page(s)</b>
<b>Cases</b>	
<i>511 Innovations, Inc. v. Apple, Inc.</i> , No. 2:16-cv-00868 (E.D. Tex.).....	1
<i>511 Innovations, Inc. v. HTC America, Inc.</i> , No. 2:15-cv-01524 (E.D. Tex.).....	1
<i>511 Innovations, Inc. v. Microsoft Mobility Inc.</i> , No. 2:15-cv-01525 (E.D. Tex.).....	1
<i>511 Innovations, Inc. v. Samsung Telecommunications America, LLC</i> , No. 2:15-cv-01526 (E.D. Tex.).....	1
<i>PPC Broadband, Inc. v. Corning Optical Communications RF, LLC</i> , 815 F.3d 734 (Fed. Cir. 2016) .....	8
<b>Statutes</b>	
35 U.S.C. § 103 .....	3
<b>Other Authorities</b>	
37 C.F.R. §§ 42.6(e)(4) and 42.105 .....	53
37 C.F.R. §§ 42.24(d) .....	53
37 C.F.R. § 42.100(b) .....	7

## EXHIBIT LIST

<b><u>Exhibit</u></b>	<b><u>Description</u></b>
1001	U.S. Patent No. 7,110,096
1002	US 7,110,096 (USAN 11/235,969) File History
1003	US 5,745,229 (USAN 08/581,851) File History
1004	U.S. Patent No. 4,653,905 (Farrar)
1005	U.S. Patent No. 5,402,508 (O'Rourke)
1006	Japanese Laid Open Patent Application No. H01-276028 (JP '028)
1007	U.S. Patent No. 4,515,275 (Mills)
1008	Declaration of R. Jacob Baker, Ph.D., P.E.

## **I. MANDATORY NOTICES**

### **A. Real Parties-in-Interest**

ams AG, AMS-TAOS USA Inc., Samsung Electronics America, Inc., and Samsung Electronics Co., Ltd. (collectively “Petitioners”) are the real parties-in-interest to this proceeding.

U.S. Patent No. 7,397,541 (the “’541 Patent”) is assigned to JLL Technologies LLC by an assignment dated July 27, 2007 and recorded on the same date at reel/frame 019597/0461. However, in the various court proceedings identified below, 511 Innovations, Inc. claims to be “the current owner by assignment of all rights, title, and interest in and under the ’541 Patent.”

### **B. Related Matters**

The ’541 Patent and other patents in the same patent family are currently asserted against Petitioners in *511 Innovations, Inc. v. Samsung Telecommunications America, LLC*, No. 2:15-cv-01526 (E.D. Tex.). The ’541 Patent and other patents in the same patent family are also currently asserted in: *511 Innovations, Inc. v. HTC America, Inc.*, No. 2:15-cv-01524 (E.D. Tex.); *511 Innovations, Inc. v. Microsoft Mobility Inc.*, No. 2:15-cv-01525 (E.D. Tex.); and *511 Innovations, Inc. v. Apple, Inc.*, No. 2:16-cv-00868 (E.D. Tex.).

In addition to this Petition, Petitioners are seeking *inter partes* review of related U.S. Patents Nos. 6,307,629, 6,490,038, 7,113,283, 6,915,955, 7,110,096, 8,472,012 and 8,786,844.

**C. Counsel**

Lead Counsel: Daniel E. Venglarik (Registration No. 39,409);

Backup Counsel: Jamil N. Alibhai (*pro hac vice* to be filed), Kelly P. Chen (*pro hac vice* to be filed), and Jacob L. LaCombe (Registration No. 63,036).

**D. Service Information**

Email: 511-AMS@munckwilson.com.

Post and Hand Delivery (all counsel): 12770 Coit Road, Suite 600, Dallas, TX 75251; Telephone: (972) 628-3600; Facsimile: (972) 628-3616.

**E. Certification of Standing**

Petitioners certify that the '541 Patent is available for *inter partes* review and that Petitioners are not barred or estopped from requesting *inter partes* review on the grounds identified herein.



## **II. OVERVIEW OF CHALLENGE AND RELIEF REQUESTED**

Petitioners challenge claims 1, 3 and 11 of the '541 Patent as indicated below:

**Ground 1:** Claims 1, 3 and 11 of the '541 Patent are obvious over Farrar in view of O'Rourke.

**Ground 2:** Claims 1, 3 and 11 of the '541 Patent are obvious over JP '028.

**Ground 3:** Claims 1, 3 and 11 of the '541 Patent are obvious over Mills.

The above grounds create a reasonable likelihood that Petitioners will prevail with respect to at least one challenged claim. The arguments, charts and evidence demonstrate that the challenged claims are unpatentable as obvious under 35 U.S.C. § 103. Petitioners request cancellation of the challenged claims.

## **III. THE '541 PATENT**

### **A. Overview of the '541 Patent**

The challenged claims are directed to the well-known idea of using optical sensors to measure the intensity of light reflected from the object, and then using the intensity measurements to determine information about the object. The patent generally discusses measuring the intensity of reflected light and using the measured intensity in an algorithm (run on the microprocessor) to determine the optical characteristics of the object. Ex. 1001, 3:31-4:39.

The '541 Patent describes a probe that measures the intensity of reflected

light to determine optical characteristics (e.g., color, “reflectivity” or luminance) of teeth. Ex. 1001, 4:10-14. As shown in Figure 1, light emitted by a light source 11 is carried by fiber optic 5 to probe body 2 and probe tip 1 to illuminate a patient’s teeth 20:

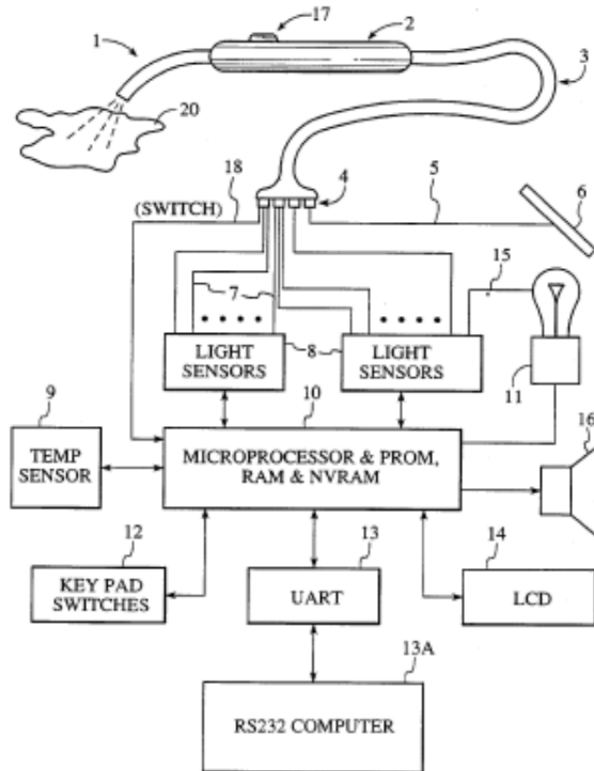
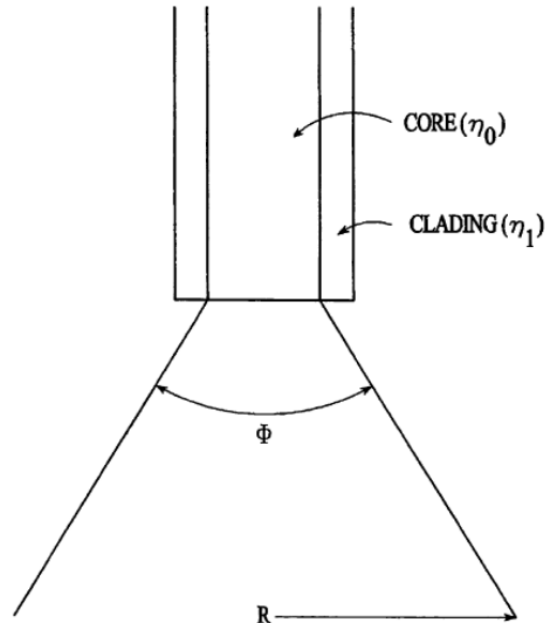

FIG. 1

Ex. 1001, Figure 1, 5:43-6:34; 6:42-49. “Light reflected from the object 20 passes through the receiver fiber optics in probe tip 1 to light sensors 8 (through probe body 2, fiber optic cable 3 and fibers 7).” Ex. 1001, 7:65-8:1. “Based on the information produced by light sensors [8], microprocessor 10 produces a color measurement result or other information to the operator.” Ex. 1001, 8:1-3.

The patent explains that when one end of a fiber optic is illuminated by a light source, “[t]he fiber optic will emit a cone of light”:



**FIG. 4A**

Ex. 1001, Figure 4A, 12:27-30. “If the fiber optic is held perpendicular to a surface it will create a circular light pattern on the surface.” Ex. 1001, 12:30-32. As the fiber optic is raised from the surface, the circle of light grows larger, and as it is lowered the circle grows smaller. Ex. 1001, 12:32-34. The intensity of light “in the illuminated circular area increases as the fiber optic is lowered and will decrease as the fiber optic is raised.” Ex. 1001, 12:34-37.

“The same principle generally is true for a fiber optic being utilized as a receiver.” Ex. 1001, 12:38-39. As shown below, “[a]s . . . two [parallel] fiber optics are held perpendicular to a surface, the source fiber optic emits a cone of light that illuminates a circular area of radius  $r$ ”:

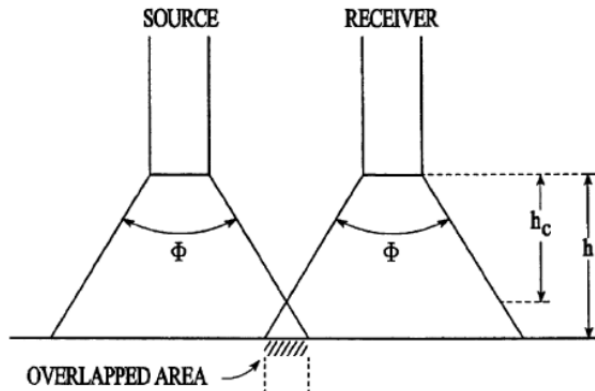

FIG. 4B

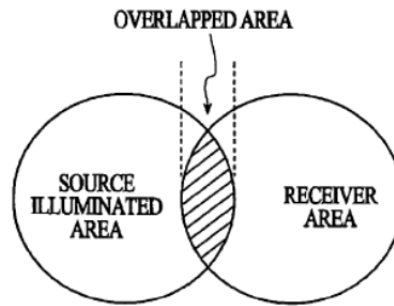

FIG. 4C

Ex. 1001, Figures 4B-4C, 12:56-59. A receiver fiber optic also has an acceptance cone within which it can receive light. Ex. 1001, 12:58-60. Light reflected from an object's surface will only be received or propagated by the receiver fiber optic where light emitted from the source fiber optic strikes the object's surface in the "overlapped area." Ex. 1001, Figure 4C, 13:60-64.

As the source and receiver fiber optics are moved closer to an object's surface, they reach a point where their cones do not intersect, and the circular areas projected onto the object's surface do not intersect. There is thus no "overlapped area," and source light reflected by the object cannot be received or propagated by the receiver fiber optic. The height at which the source and receiver cones cease to intersect is referred to as the "minimal height." Ex. 1001, 17:51-53. To account for the effects of distance and other variables of the probe, the patent describes a "critical height"—the distance from the probe to a specific object at which the intensity of reflected light is at its peak. Ex. 1001, 13:17-21. The patent teaches that when determining the optical characteristics of the object, values taken at the

critical height should be used to eliminate the effect of distance on determination of such characteristics. See, e.g., Ex. 1001, 1:22-27, 2:20-24, 3:31-34,4:1-6, 13:22-42, 16:37-40.

#### **B. Admitted Prior Art**

The '541 Patent admits prior art knowledge that color is dependent on the wavelength(s) of reflected light and that light incident on an object will, when reflected, “vary in intensity and wavelength dependent upon the color of the surface of the object.” Ex. 1001, 1:37-44. Admitted prior art color measurement devices (“colorimeters”) shine “white” light on the object and measure the intensity of reflected light received through filters passing only bands of wavelengths, such as red, green, and blue color filters. Ex. 1001, 1:31-36, 1:45-2:4. The intensity measurements from the three (red/green/blue) “color sensors” represent the color. Ex. 1001, 2:8-15. Admitted prior art light sensors such as the commercially available TSL230 or TSL213 and admitted prior art filter materials such as Kodak filters are disclosed for such system components. Ex. 1001, Figs. 1 & 3, 9:18-41, 10:17-37.

#### **IV. ORDINARY SKILL IN THE ART**

A person of ordinary skill in the art at the time of the claimed inventions would have had a bachelor’s degree in electrical engineering, physics, or a closely related field, along with at least 2-3 years of experience in the design and

development of optoelectronic measurement systems. An individual with an advanced degree in a relevant field, such as physics or electrical engineering, would require less experience in the design and development of optoelectronic measurement systems.

## **V. CLAIM CONSTRUCTION**

The '541 Patent expired on January 2, 2016. In reviewing a patent that has expired or will expire before the final decision, the Board applies the “district court” or *Phillips* claim construction standard. 37 C.F.R. § 42.100(b). Under that standard, the “correct” construction—that most accurately delineating the scope of the invention—is identified. *PPC Broadband, Inc. v. Corning Optical Communications RF, LLC*, 815 F.3d 734, 740 (Fed. Cir. 2016).

As shown below, the prior art renders obvious claims 1, 3 and 11 of the '541 Patent; accordingly, the Board need not consider any claim terms for purposes of invalidity.

## **VI. GROUND 1: Claims 1, 3 and 11 of the '541 Patent are obvious over Farrar in view of O'Rourke.**

### **A. Overview of Farrar**

Farrar relates to a fiber optic range finder determining a range 14 to the surface of an object 13. Ex. 1004, Title, 2:58-66. Figure 1 is representative of the general structure and operation:

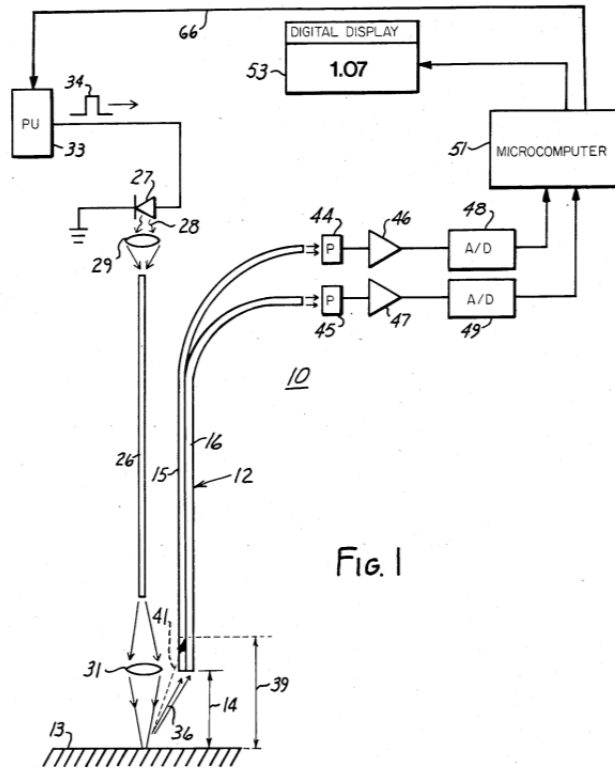

FIG. 1

Ex. 1004, Figure 1. The range finder 10 includes a light transmitting optical fiber 26 together with light receiving optical fibers 15 and 16. Ex. 1004, 2:58-66, 3:49-51, 5:18-20. The light transmitting optical fiber 26 projects light from a light source 27 onto the object surface. Ex. 1004, 3:52-56. Light receiving optical fibers 15 and 16 receive a portion of that light reflected by the object (reflected light 36 or 41). Ex. 1004, 3:64-4:6. Photodetectors 44 and 45 respectively receive light from the light receiving fibers 15 and 16, measure the intensity, and generate corresponding electrical signals that are then amplified by amplifiers 46, 47 and digitized by A/D converters 48, 49. Ex. 1004, 4:59-65. A microprocessor 51 calculates the range 14 to the object surface based on a mathematical combination

of the digitized light intensities measured by the two photodetectors 44 and 45. Ex. 1004, 5:3-7. By mathematically combining both measured light intensities (received at different angles through fibers 15 and 16 having different numerical apertures), the range calculated by microprocessor 51 accounts for variations in overall light intensity or caused by the specific texture or reflectivity of object surface 13. Ex. 1004, 4:32-42, 5:67-6:10.

Figure 6 of Farrar is a range finder functionally similar to Figure 1. Ex. 1004, 7:27-32, 7:51-54. Only light receiving fiber 15 is employed, with narrowband optical filters 67 and 68 corresponding to different wavelength ranges between the fiber 15 and photodetectors 44 and 45. Ex. 1004, Figure 6, 7:16-23. A single broadband (xenon) light source 71 covering the wavelength transmission bands of filters 67 and 68 supplies light to light transmitting fiber 26. Ex. 1004, Figure 6, 7:37-46. With the same broadband light and optical filters of different wavelength ranges, the electric signals output by photodetectors 44, 45 correspond to the spectral response of the object surface 13 in different wavelength bands. Ex. 1008, ¶¶ 22, 44. Spectral response (e.g., “color”) is a property of the object’s surface that affects the object’s response to light (“optical characteristics”). Ex. 1008, ¶ 24.

Light transmitting fiber 26 is separated from light receiving fiber 15 by a space 58 from the light receiving optical fibers 15 (“A”):



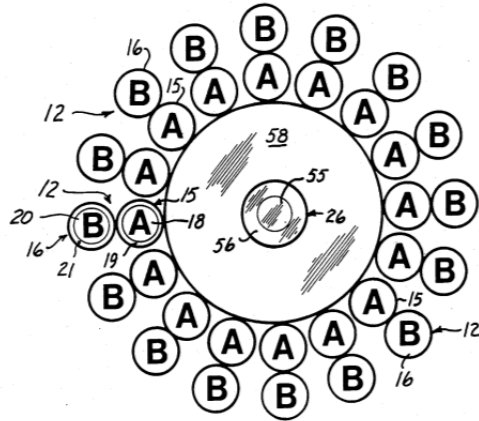

Ex. 1004, Figure 3, 5:38-48. As a result, the light transmitting fiber 26 and light receiving fiber 15 necessarily exhibit a “minimum height” based on the respective fiber numerical apertures, as described in the ’541 Patent and recognized in the prior art. O’Rourke discloses that a light source fiber 32 forms an emission cone 86 and a light receiving fiber 34 has an acceptance cone 88, each defined by the direction of central rays 92 and 94 and half-angle  $\omega$  for the respective cones 86 or 88:

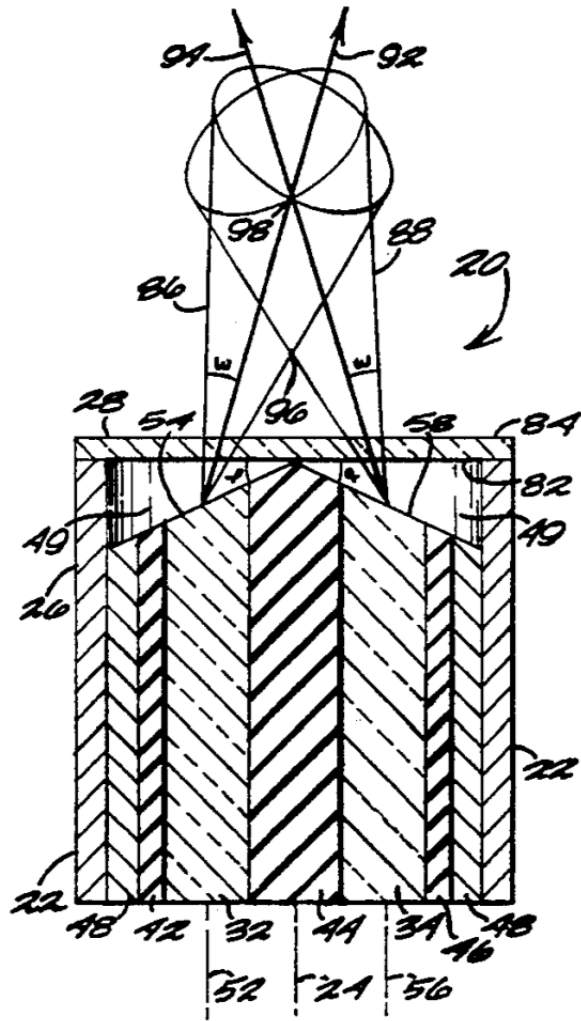

Ex. 1005, Figure 3, 3:36-38, 3:46-51, 5:66-51, 5:59-6:13, 6:44-67. First and second cones 86 and 88 intersect at a minimum crossing point 96, which “is the first point where extreme rays from first and second light cones 86, 88 cross and is the minimum distance at which light from one of transmitting and receiving fibers 32, 34 can scatter into the other.” Ex. 1005, Figure 3, 6:10-13, 6:62-65. A “minimal height” is an intrinsic characteristic of light transmitting/receiving fiber pairs, such that light transmitting fiber 26 and light receiving fiber 15 in Farrar necessarily have a corresponding minimum height.

## B. Overview of O'Rourke

Similar to the fiber optic means in Farrar, O'Rourke relates to a fiber optic probe. Ex. 1005, Abstract. O'Rourke is analogous to Farrar in the use of a light transmitting fiber to emit light and a light receiving fiber to receive reflected light.

O'Rourke relates to fiber optic probes for spectral analysis, providing light from a source fiber and receiving reflected light by a receiving fiber for comparison of the received, reflected light with the source light. Ex.1005, 1:14-15, 1:19-29. O'Rourke discloses a fiber optic probe 20 including a light source or transmitting fiber 32 and a light receiving fiber 34 within a housing 22:

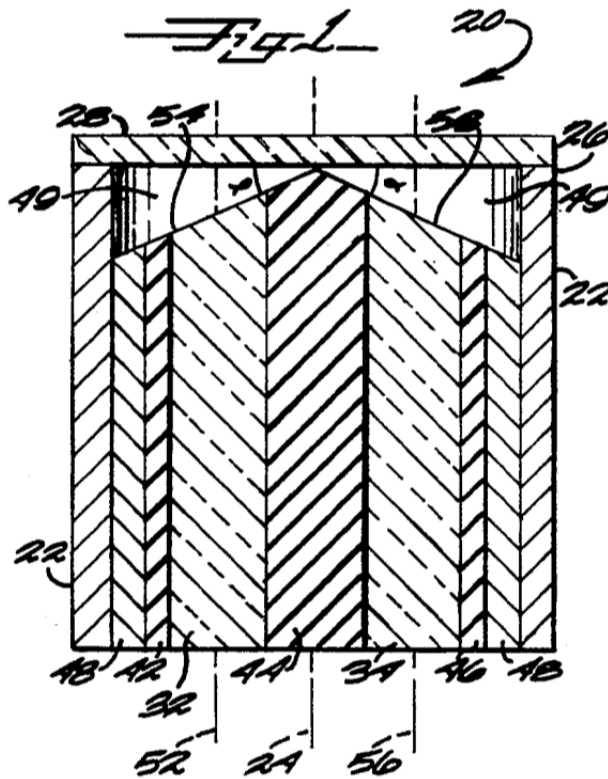

Ex. 1005, Figure 1, 3:36-38, 3:46-51, 5:66-51. The light transmitting and receiving fibers 32 and 34 are held by epoxy 42, 44 and 46, which contains a light-absorber such as carbon black to inhibit direct coupling (“crosstalk”) between fibers 32 and 34. Ex. 1005, 3:46-51, 5:46-51, 7:5-12. A thin sapphire window 28 extends over the ends of fibers 32 and 34. Ex. 1005, 3:59-63, 5:51-58. “[W]indow 28 must be positioned close enough to transmitting and receiving fibers 32, 34 so that direct reflection from transmitting fiber 32 to receiving fiber 34 is avoided.” Ex. 1005, 3:63-66.

**C. Farrar in view of O’Rourke Render Claims 1, 3 and 11 Obvious**

1. *Claim 1:*

Farrar discloses an apparatus that receives reflected light, measures the intensity of the reflected light (using algorithm run on the microprocessor) to determine a distance to the object surface, and displays the result determined from measurement of the reflected light.

[1a] “*A method for determining optical characteristics of an object, comprising the steps of:*”

Farrar discloses fiber optic range finder systems. Ex. 1004, Figures 1 & 6, Title, Abstract. Fiber optic range finder 10 includes photodetectors 44 and 45 each measuring an intensity of light reflected from an object surface 13. Ex. 1004, Figures 1 & 6, 4:46-49, 4:59-62, 7:51-54. The photodetector outputs correspond to

the spectral response of the object surface 13 in the different wavelength transmission bands (i.e., “colors”) of filters 67 and 68. Ex. 1008, ¶¶ 25, 44.

[1b] *“providing light to the object from one or more light sources, and receiving light from the object through one or more light receivers,”*

Light transmitting fiber 26 and light receiving fiber 15 are positioned so that reflected light 36 from light transmitting fiber 26 reflected off the object surface 13 is received by light receiving fiber 15. Ex. 1004, Figures 1 & 6, 3:49-56, 3:64-4:6, 7:51-54. The light transmitting and receiving fibers 26/15 are in sufficient proximity to the object 13 to allow fiber 15 to receive reflected light from object. Figure 6 includes a broadband light source 71 driven by a pulsing unit 33 controlling the pulsing of LED 27. Ex. 1004, Figures 1 & 6, 3:52-4:6, 7:37-40, 7:47-54. Light transmitting fiber 26 provides light to the object 13, and light receiving fiber 15 receives reflected light 36 from the object 13. *Id.*

[1c] *“wherein the one or more light sources and one or more light receivers define at least one minimal height, wherein, below the minimal height, light that is reflected from a surface of the object is not propagated by the one or more light receivers,”*

The “minimal height” characteristic described and claimed in the ’541 Patent is inherent to fiber optic pairs used to shine light onto an object and receive

light reflected from the object surface. Ex. 1005, Figure 3, 3:36-38, 3:46-51, 5:66-51, 5:59-6:13, 6:62-65. The spaced light transmitting fiber 26 and light receiving fiber 15 inherently define a minimal height between the apparatus and an external object, below which the cones of emission and acceptance for the light transmitting fiber 26 and light receiving fiber 15 no longer intersect and light from light transmitting fiber 26 reflected off object surface 13 is not received or carried by light receiving fiber 15. Ex. 1004, Figure 3, 5:26-48, 7:51-54; Ex. 1008, ¶¶ 46, 47. One skilled in the art would understand, from the teachings of Farrar and O'Rourke, that the spaced light transmitting fiber 26 and light receiving fiber 15 define a minimal height between the apparatus and an external object, below which the cones of emission and acceptance for the light transmitting fiber 26 and light receiving fiber 15 no longer intersect such that light from light transmitting fiber 26 reflected off object surface 13 is not received or carried by light receiving fiber 15. Ex. 1008, ¶¶ 46, 47.

[1d] *“wherein the light is provided to the object and received from the object through a protective barrier having a thickness, wherein the thickness is less than the minimal height;”*

Farrar expressly states that only schematic illustrations and only description of the principal or essential structure for the range finder 10 is provided. Ex. 1004, 5:11-12. Farrar further expressly states that “secondary details” of construction

from other patents, such as those incorporated by reference, may be employed together with the components explicitly depicted and described. Ex. 1004, 5:12-17, 5:52-56.

In an analogous system, O'Rourke teaches a thin sapphire window 28 across the end 26 of a housing 22 within which fibers 32 and 34 are held. Ex. 1005, 3:59-63. The sapphire window 28 is structure that separates the source/receiver fibers and the object, and protects the source/receiver fibers ("protective barrier"). Ex. 1005, Abstract ("The probe comprises a housing with a transparent window across its tip for *protecting* the transmitting and receiving fibers held therein.") (emphasis added). Source fiber 32 provides light through window 28 to external objects and receiver fiber 34 receives light originating outside probe 20 through window 28. Ex. 1005, Figure 3, 5:59-6:9, 6:44-66. O'Rourke also teaches that the window 28 should be thin and positioned closer to fibers 32, 34 than the minimum crossing point 96 to avoid direct reflection between transmitting fiber 32 and receiving fiber 34. Ex. 1005, Figure 3, 3:63-68, 6:16-25.

One having ordinary skill in the art would be motivated to use the housing 22 and window 23 of O'Rourke to house fibers 26 and 15 in Farrar's Figure 6, as part of the "secondary details" of construction for the range finder schematically depicted in Farrar. Ex. 1004, 5:12-17, 5:52-56. One skilled in the art would be motivated to use the housing 22 and window 28 in order to dispose fibers within an

environment of “a gas or air having a known index of refraction so that the behavior of the light once it leaves the transmitting fibers and as it approaches the receiving fibers is as expected” and to “protect[] the fibers from exposure to” contaminants to “extend[] the life of the optical fibers.” Ex. 1005, 3:10-21; Ex. 1008, ¶¶ 48, 49. In using the housing 22 and window 28 of O’Rourke to hold fibers 26/15 of Farrar, one skilled in the art would be motivated to position the window within the minimal height of fiber pair 26/15 to avoid direct reflection between fiber 26 and fibers 15. Ex. 1008, ¶¶ 48, 49.

[1e] “*measuring the intensity of light received and propagated by one of the one or more light receivers;*”

Photodetectors 44 and 45 respectively receive light from the light receiving fibers 15, measure the intensity, and generate corresponding electrical signals. Ex. 1004, 4:59-65.

[1f] “*determining the optical characteristics of the object based in response to one or more intensity measurements.*”

A single broadband light source 71 supplies light to light transmitting fiber 26 and narrowband optical filters 67 and 68 of different wavelength transmission ranges filter the light (divided by beamsplitter 69) from a light receiving fiber 15. Ex. 1004, Figure 6, 7:16-54. The light intensity measurements output by photodetectors 44, 45 indicate the spectral reflectivity of the object surface 13 in



different wavelength bands of light (i.e., “colors”). Ex. 1008, ¶¶ 42-44. One skilled in the art would understand that the light intensity measurements output by photodetectors 44, 45 indicate the spectral reflectivity of the object surface 13 in different wavelength bands of light, since Farrar teaches using a combination of the two measurements to eliminate or reduce the influence of reflectivity on range determination. Ex. 1004, 4:32-5:7; Ex. 1008, ¶¶ 42-44.

2. *Claim 3*

[3b] *“wherein at least one measurement is taken below the minimal height.”*

Those skilled in the art would understand that the Farrar’s rangefinder is capable of taking a measurement with the ends of fibers 26/15 positioned closer to the object surface 13 than the minimal height. To avoid direct reflection between fibers 26/15, the window over the fiber ends should be thinner than the minimal height as taught by O’Rourke. With that configuration, the ends of fibers 26/15 may be positioned closer to the object surface 13 than the minimal height. Ex. 1008, ¶¶ 48, 49. Farrar’s rangefinder determines a range to objects that “move[] away from or toward the receive fiber input faces.” Ex. 1005, 4:20-22. It would be obvious to take a measurement below the minimal height when the object moves closer to the fibers 26/15 than the minimal height. Ex. 1008, ¶¶ 48, 49.

3. *Claim 11*

[11b] *“wherein one or more sensors are coupled to the one or more light receivers,”*

Photodetectors 44 and 45 respectively receive light from the light receiving fiber 15 via filters 67-68 and beamsplitter 69. Ex. 1004, Figure 6, 4:59-65.

[11c] *“wherein the one or more sensors produce data indicative of a physical position with respect to the object.”*

Photodetectors 44 and 45 produce electrical signals that are amplified and digitized, with the digital value for the measured light intensity is provided to microprocessor 51. Ex. 1004, 4:59-65, 7:27-32, 7:51-54. Microprocessor 51 uses the digital values of the measured light intensities to determine, by mathematical combination of the digital values, the range from the ends of light receiving fibers 15 to the object surface. Ex. 1004, Figure 6, 4:59-65, 5:3-10, 5:67-6:6, 7:47-54.

**D. Charts**

<b>Limitation</b>		<b>Farrar+O’Rourke</b>
1a	A method for determining optical characteristics of an object, comprising the steps of:	Farrar discloses fiber optic range finder systems. Ex. 1004, Figure 6, Abstract. Fiber optic range finder includes photodetectors 44 and 45 each measuring an intensity of light reflected from an object surface 13. Ex. 1004, Figure 6, 4:46-49, 4:59-62. Narrowband optical filters 67 and 68 corresponding to different wavelength ranges are positioned in front of photodetectors 44 and 45, and a single broadband light source 71 provides light to the object. Ex. 1004, Figure 6, 7:16-

<b>Limitation</b>		<b>Farrar+O'Rourke</b>
		54, 7:37-40. The electric signals output by photodetectors 44, 45 in Figure 6 correspond to the spectral response of the object surface 13 in different wavelength bands. Ex. 1008, ¶¶ 25, 44.
1b	providing light to the object from one or more light sources, and receiving light from the object through one or more light receivers,	Light transmitting fiber 26 and light receiving fibers 15 are positioned so that reflected light 36 emitted by light transmitting fiber 26 and reflected off the object surface 13 is received by light receiving fiber 15. Ex. 1004, Figure 6, 3:49-56, 3:64-4:6, 7:27-32, 7:51-54. Xenon lamp 71 provides light via transmitting fiber 26 to the object 13, and light receiving fibers 15 receive reflected light 36 from the object 13. Ex. 1004, Figure 6, 3:52-4:6 7:37-40, 7:51-54.
1c	wherein the one or more light sources and one or more light receivers define at least one minimal height, wherein, below the minimal height, light that is reflected from a surface of the object is not propagated by the one or more light receivers,	<p>A minimal height between the fibers 26/15 and an external object is inherently defined by the spaced light transmitting fiber 26 and light receiving fiber 15, below which the cones of emission and acceptance for the light transmitting fiber 26 and light receiving fiber 15 no longer intersect and light from light transmitting fiber 26 reflected off object surface 13 is not received or carried by light receiving fiber 15. Ex. 1004, Figure 3, 5:26-48, 7:51-54; Ex. 1008, ¶¶ 46, 47.</p> <p>In addition, O'Rourke teaches that the source fiber 32 forms an emission cone 86 and the receiver fiber 34 has an acceptance cone 88. Ex. 1005, 5:59-61. The minimum crossing point 96 ("minimal height" relative to the endfaces of the fibers 32 and 34) of cones 86 and 88 may be determined based on the direction of the central rays 92 and 94 and half-angle <math>\omega</math> for the respective cones 86 or 88. Ex. 1005, Figure 3, 5:61-6:13, 6:44-67; Ex. 1008, ¶¶ 46, 47. When the probe is closer to</p>

	<b>Limitation</b>	<b>Farrar+O'Rourke</b>
		<p>an object than the distance to minimum crossing point 96, light emitted by the source fiber 32 and reflected off the object is not received by the receiver fiber 34. Ex. 1008, ¶¶ 46, 47.</p> <p>One skilled in the art would be motivated to adjust the minimal height for fiber pair 26/15 by beveling the end faces of the light receiving fibers 15, altering the direction of the respective acceptance cones, in order to improve the light coupling efficiency of the fibers and eliminate the need for lens 31. Ex. 1005, 7:31-41; Ex. 1008, ¶¶ 46, 47.</p>
1d	<p>wherein the light is provided to the object and received from the object through a protective barrier having a thickness, wherein the thickness is less than the minimal height;</p>	<p>O'Rourke discloses a thin sapphire window 28 across the end 26 of a housing 22 within which fibers 32 and 34 are held to protect the fibers. Ex. 1005, 3:59-63. Light from source fiber 32 is provided through window 28 to external objects and light originating outside probe 20 is received by receiver fiber 34 through window 28. Ex. 1005, Figure 3, 5:59-6:9, 6:44-66. One skilled in the art would be motivated to use the housing 22 and window 23 of O'Rourke to house fibers 26/15, to protect the fibers from exposure to contaminants. Ex. 1005, 3:10-21; Ex. 1008, ¶¶ 48, 49.</p>
1e	<p>measuring the intensity of light received and propagated by one of the one or more light receivers;</p>	<p>Photodetectors 44 and 45 respectively receive light from the light receiving fiber 15 via filters 67-68 and beamsplitter 69, measure the intensity, and generate corresponding electrical signals. Ex. 1004, 4:59-65 7:27-32, 7:51-54.</p>
1f	<p>determining the optical characteristics of the object based in response to one or more intensity measurements.</p>	<p>Broadband light source 71 supplying light to light transmitting fiber 26 and narrowband optical filters 67 and 68 of different wavelength ranges filtering the light (divided by beamsplitter 69) from a single light</p>

<b>Limitation</b>		<b>Farrar+O'Rourke</b>
		receiver fiber 15. Ex. 1004, Figures 5-6, 7:16-54. The light intensity measurements output by photodetectors 44, 45 correspond to the spectral response of the object surface 13 in the different wavelength transmission bands of filters 67, 68. Ex. 1008, ¶¶ 42-44.
3a	The method of claim 1,	See [1a]-[1f].
3b	wherein at least one measurement is taken below the object that is less than the minimal height.	Those skilled in the art would understand that the Farrar's rangefinder is capable of taking a measurement with the ends of fibers 26/15 positioned closer to the object surface 13 than the minimal height. To avoid direct reflection between fibers 26/15, the window over the fiber ends should be thinner than the minimal height as taught by O'Rourke. With that configuration, the ends of fibers 26/15 may be positioned closer to the object surface 13 than the minimal height. Ex. 1008, ¶¶ 48, 49. Farrar's rangefinder determines a range to objects that "move[] away from or toward the receive fiber input faces." Ex. 1005, 4:20-22. It would be obvious to take a measurement below the minimal height when the object moves closer to the fibers 26/15 than the minimal height. Ex. 1008, ¶¶ 48, 49.
11a	The method of claim 1,	See [1a]-[1f].
11b	wherein one or more sensors are coupled to the one or more light receivers,	Photodetectors 44 and 45 respectively receive light from the light receiving fiber 15. Ex. 1004, Figure 6, 4:59-65, 7:27-32, 7:51-54.
11c	wherein the one or more sensors produce data indicative of a physical position with respect to the object.	Photodetectors 44 and 45 produce electrical signals that are amplified and digitized, with the digital value for the measured light intensity is provided to microprocessor 51. Ex. 1004, 4:59-65, 7:27-32, 7:51-54. Microprocessor 51 uses the digital values of the light intensity to determine, by mathematical combination of the digital values, the range from the end of light

	<b>Limitation</b>	<b>Farrar+O'Rourke</b>
		receiving fiber 15 to the object surface. Ex. 1004, Figure 1, 4:59-65, 5:3-10, 5:67-6:6, 7:27-32, 7:51-54.

**VII. GROUND 2: Claims 1, 3 and 11 of the '541 Patent are obvious over JP '028.**

This ground is not redundant with Grounds 1 because JP '028 discloses determination of an optical property of light, RGB color, different from the two wavelength band spectral response optical property disclosed by a reference in Ground 1.

**A. Overview of JP '028**

JP '028 describes a non-contact colorimeter B for automated color measurement of items, using optical means both to set a distance between the colorimeter input(s) and the object to be measured to a prescribed distance (to avoid inaccurate color measurement) and to measure the object's color. Ex. 1006, Figure 6, 214-l<sup>1</sup>, 220-l. A xenon light source 1 emits light projected by lens 38 onto the object 40:

---

<sup>1</sup> For convenience, "l" and "r" are used to designate the left and right columns, respectively, on the indicated page.

第 2 圖

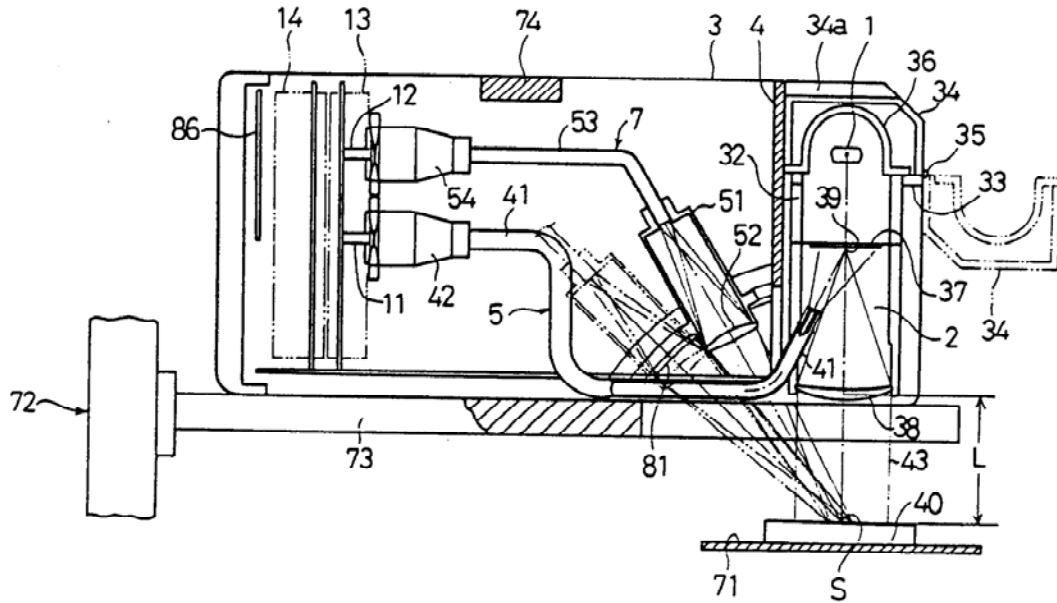

FIG. 3

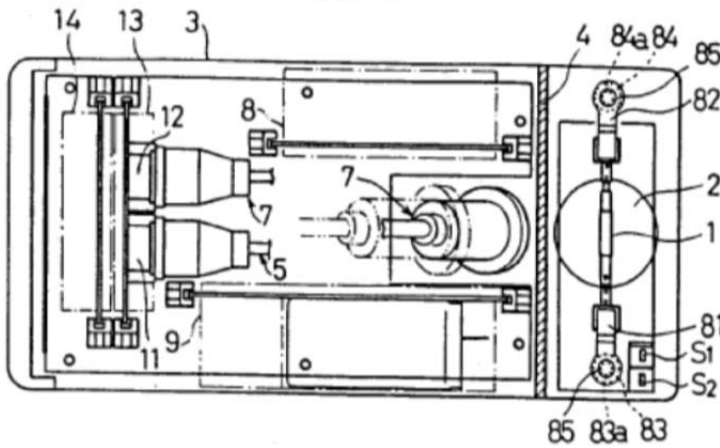
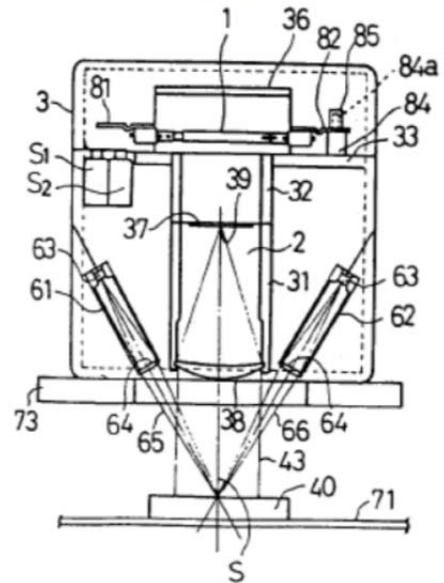

FIG. 4



Ex. 1006, Figures 2-4, 215-r. A light source monitor 5 includes an optical fiber 41 receiving light from the light source 1 and carrying the received light to a diffusion chamber 42, which guides that received light to sensor 11. Ex. 1006, Figure 2,

215-r to 216-l. A sample monitor 7 has a light receiving lens tube 51 with light receiving lens 52 through which light reflected light from the object 40 at the measurement position S is focused on a light receiving optical fiber 53 carrying the received, reflected light to a diffusion chamber 54 guiding that light to a sensor 12. Ex. 1006, Figure 2, 216-l.

Sensor 11 in light source monitor 5 includes color component filters  $F_1$ - $F_n$  color-filtering the received light passed to detectors  $D_1$ - $D_n$  measuring the intensity of the color components of the source light:

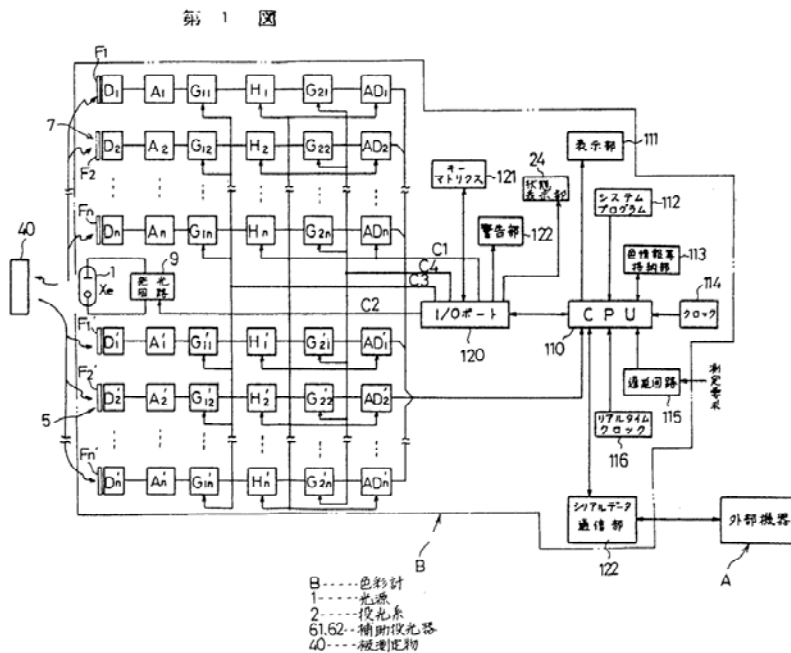

Ex. 1006, Figure 1, 217-r. The outputs of detectors  $D_1$ - $D_n$  are amplified by amplification circuits  $A_1$ - $A_n$  connected by gate circuits  $G_{11}$ - $G_{1n}$  to sample and hold circuits  $H_1$ - $H_n$ , which are connected by gate circuits  $G_{21}$ - $G_{2n}$  to A/D conversion circuits  $AD_1$ - $AD_n$ . Ex. 1006, Figure 1, 218-l.



Sensor 12 in sample monitor 7 includes color component filters  $F_1'-F_n'$  color-filtering the received light passed to detectors  $D_1'-D_n'$  measuring the intensity of the color components of the light reflected from object 40. Ex. 1006, Figure 1, 217-r. The outputs of detectors  $D_1'-D_n'$  are amplified by amplification circuits  $A_1'-A_n'$  connected by gate circuits  $G_{11}'-G_{1n}'$  to sample and hold circuits  $H_1'-H_n'$ , which are connected by gate circuits  $G_{21}'-G_{2n}'$  to A/D conversion circuits  $AD_1'-AD_n'$ . Ex. 1006, Figure 1, 218-l.

CPU 110 receives digital values for the measured color components of both source and reflected light. Ex. 1006, 218-r (“The photometric value of the respective basic color components converted into digital signals by the A/D conversion circuits  $AD_1-AD_n$ ,  $AD_1'-AD_n'$  are input into the CPU 110.”).

To ensure object 40 is at measurement position S that is a prescribed distance L from input lens tube 51, two auxiliary light projectors 61, 62 emit light and are positioned so that the resulting optical paths 65, 66 intersect each other and the main optical path 43 at measurement position S:

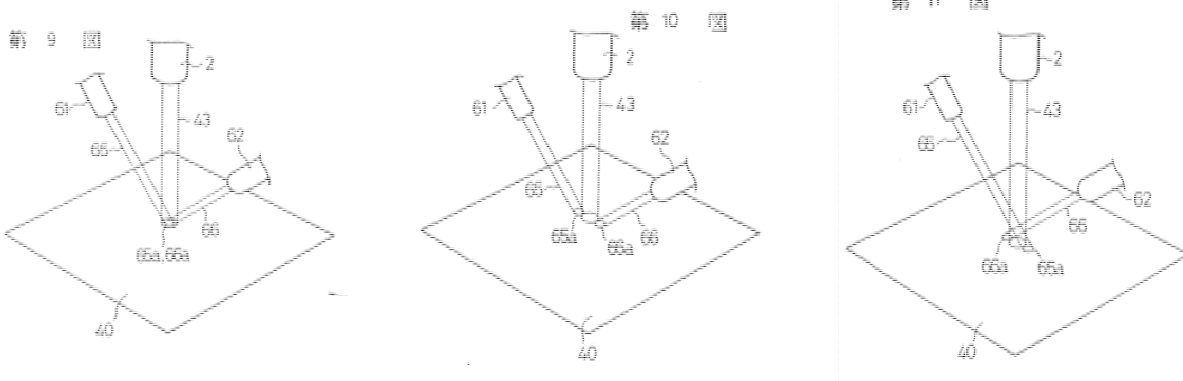

Ex. 1006, Figures 9-11, 216-l to 216-r. Auxiliary projectors 61, 62 flash light along the optical paths 65, 66 of two colors different from each other and from the color of light from the main optical path 43 to enable determination of when the object is at the correct measurement position S. Ex. 1006, 214-r to 215-l, 216-r, 216-r to 217-l. Light color component intensity measurements by sensor 12 allow determination of when the object 40 is at the prescribed distance L for accurate color measurement, when the spots 65a and 66a coincide with each other and the spot for beam 43. Ex. 1006, Figure 9, 216-r to 217-l. By analyzing the intensity for each reflected light color based upon one or both of the alternate flashing or different colors from auxiliary projectors 61, 62, the separation or overlap of the projected images 65a, 66a of light 65, 66 from projectors 61, 62 allow determination of an offset direction from the prescribed distance L. Ex. 1006, Figures 10-13, 216-r to 217-l. Light intensity measurements by the sensors 11, 12 also allow color determination from light reflected off object 40. Ex. 1006, 220-l to 220-r.

**B. JP '028 Renders Claims 1, 3 and 11 Obvious**

1. *Claim 1*

[1a] “A method for determining optical characteristics of an object, comprising the steps of:”

JP '028 discloses colorimeter B that implements an algorithm for determining tristimulus color values X, Y, and Z for the color of an object 40. Ex. 1006, Figures 2 & 6, 215-r, 216-l, 219-l, 220-l. Color is a property of the object's surface that affects the object's response to light (“optical characteristic”).

[1b] “providing light to the object from one or more light sources, and receiving light from the object through one or more light receivers,”

Colorimeter B is positioned to receive light from light source 1 that is reflected off object 40. JP '028 describes a light source monitor 5 including a sensor 11 measuring light from a light source 1 using detectors  $D_1$ - $D_n$  and a sample monitor 7 including a sensor 12 measuring light reflected from object 40 using detectors  $D'_1$ - $D'_n$ . Ex. 1006, Figure 2, 215-l, 216-l. An optical fiber 41 carries light from the light source 1 to a diffusion chamber 42 containing sensor 11, and an optical fiber 53 carries light reflected from the object 40 from a light receiving lens tube 51 to a diffusion chamber 54 containing sensor 12. Ex. 1006, Figure 2, 215-l, 216-l. Colorimeter B provides light from a xenon light source 1 projected by lens

38 onto the object 40 and from auxiliary source(s) 63/100 via two auxiliary light projectors 61, 62. Ex. 1006, Figures 2-4, 215-r, 216-l, 216-r. Optical fiber 53 in colorimeter B carries light reflected from the object 40 from a light receiving lens tube 51 to a diffusion chamber 54 containing sensor 12. Ex. 1006, Figure 2, 215-l, 216-l. Optical fiber 53 is therefore a fiber optic receiving reflected light (“light receiver”).

[1c] *“wherein the one or more light sources and one or more light receivers define at least one minimal height, wherein below the minimal height, light that is reflected from a surface of the object is not propagated by the one or more light receivers,”*

JP ‘028 describes a lens 52 in light receiving lens tube 51 (which is optically coupled to sensor 12 in sample monitor 7 by optical fiber 53) as focused to receive light reflected from an object surface at position S that is a prescribed distance L (a first “minimal height”) from the projection lens 38 within the main optical path 43 from light source 1:

第 2 図

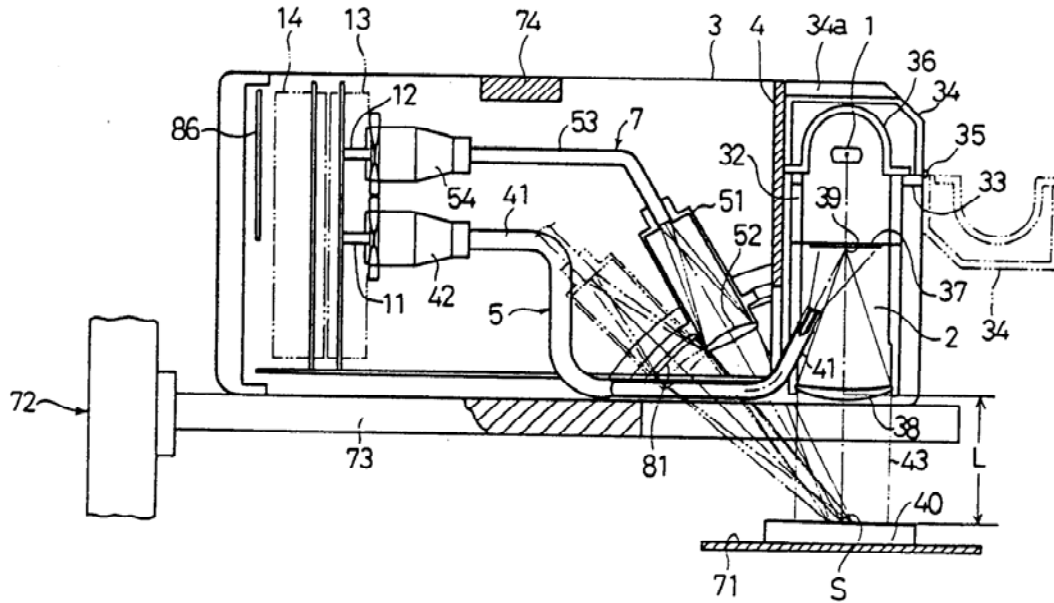

When the surface of object 40 is at a distance less than  $L$  (a first “minimal height”), at least some light emitted by from light source 1 along optical path 43 and reflected off object 40 is not received by the sensor 12 in sample monitor 7 via optical fiber 53 because the intensity varies, even if the illuminated area remains the same. Ex. 1006, 216-1 (“[I]f the prescribed distance is not set within a certain range, measurement cannot be carried out accurately due to the effect of changes in illumination intensity.”)

In addition, when the surface of object 40 is at some distance less than  $L$ , light from the two auxiliary light projectors 61, 62 is not projected onto the focal area of lens 52 and is not received by sensor 12 within sample monitor 7 via optical fiber 53:

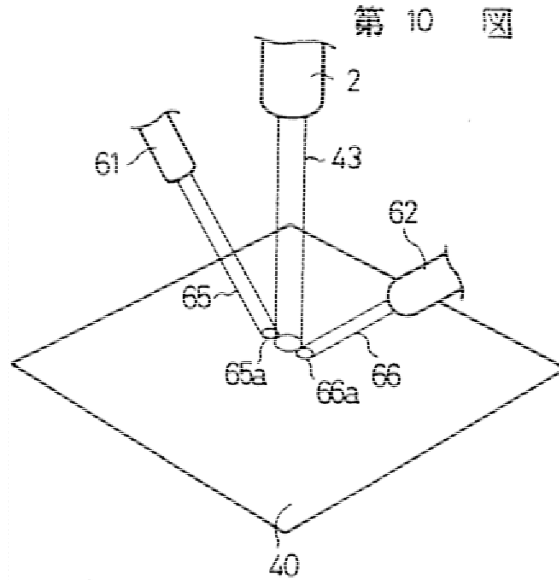

Ex. 1006, Figure 10, 216-r (“[I]f the respective projection optical paths 65, 66 are separated as in Figure 10 then the measurement distance is too close . . .”). Ex. 1006, 216-r (“Also, the projected light point of agreement where the projection images 65a, 66a accumulate, from the up and down optical change, this point of agreement is clearly demonstrated by the received optical image point of the light-receiving lens tube 51 and the measurement image part of the point of agreement of the projection images 65a, 66a of the object to be measured 40.”). The columnar cones of emitted light 65 and 66 do not intersect with the inverted cone for light receiving lens 52 at some distance (a second “minimal height”) below prescribed distance L, as generally illustrated by Figure 10.

Finally, JP '028 illustrates the intersection of the columnar cone for main optical path 42 with the inverted cone for light receiving lens 52:

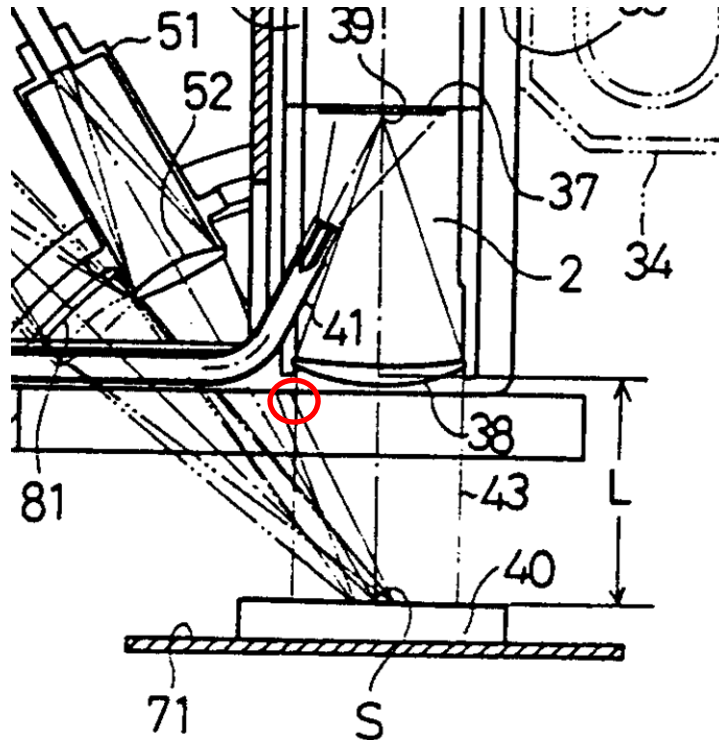

Ex. 1006, Figure 2; Ex. 1008, ¶¶ 53-57. As illustrated in Figure 2, below the cone intersection (located at some distance below the prescribed distance L), even light 43 from light source 1 is not received by the optical fiber 53 via light receiving lens tube 51. Ex. 1008, ¶¶ 53-57. That point corresponds to a distance below which a cone of emitted light [43] does not intersect with a cone for receiving light (a third “minimal height”). Ex. 1008, ¶¶ 53-57.

[1d] “wherein the light is provided to the object and received from the object through a protective barrier having a thickness, wherein the thickness is less than the minimal height;”

JP '028 describes a projection lens 38 and a light receiving lens 52, through which light source 1 provides light external to the colorimeter and through which

sensor 12 receives light reflected off object 40 external to the colorimeter. Ex. 1006, Figure 2, 215-r, 216-l. Projection lens 38 and light receiving lens 52 are a protective barrier that separates the light source 1/optical fiber 53 and the object 40. See '096 at 17:61-63. The projection lens 38 and light receiving lens 52 are depicted in Figure 2 of JP '038 as having a thickness, which is within or below the prescribed distance L (“the minimal height”) to the object surface. Ex. 1006, Figure 2; Ex. 1008, ¶¶ 58, 59.

[1e] *“measuring the intensity of light received and propagated by one of the one or more light receivers;”*

JP '028 describes the detectors  $D_1'$ - $D_n'$  in sensor 12 of sample monitor 7 as measuring light intensity for the basic color components of reflected light received via optical fiber 53. Ex. 1006, 217-r, 218-l (“A sensor 12 also has filters  $F_1'$ ,  $F_2'$ , .....  $F_n'$  that analyze the light guided to the object to be measured monitor 7 on the for basic color components at the same time as sensor 11 and these respective analyzed basic color components are photoelectrically converted to an electric signal by the basic color components detectors  $D_1'$ - $D_n'$  of the photoelectric transfer circuit 13. . . . . The photometric value of the respective basic color components converted into digital signals by the A/D conversion circuits  $AD_1$ - $AD_n$ ,  $AD_1'$ - $AD_n'$  are input into the CPU 110”).



[1f] “*determining the optical characteristics of the object based in response to one or more intensity measurements.*”

JP '028 describes calculating tristimulus color values X, Y, and Z based on digital sample monitor data MS(i) of color light intensities measured by the sensor 12 of sample monitor 7 divided by digital light source monitor data MR(i) of color light intensities measured by the sensor 11 in light source monitor 5. Ex. 1006, 219-l, 219-r.

2. *Claim 3:*

[3b] “*wherein at least one measurement is taken below the minimal height.*”

Figure 10 depicts a light intensity measurement taken with the colorimeter positioned a distance from the object surface that is less than the prescribed distance L. Ex. 1006, Figure 10. At that position below the prescribed distance L, the light spots 65a and 66a from the auxiliary projectors do not coincide with the light spot from the main optical path 43 or with the focal point of light receiving lens 52. Ex. 1006, 216-r; Ex. 1008, ¶¶ 53-57.

3. *Claim 11*

[11b] *“wherein one or more sensors are coupled to the one or more light receivers,”*

JP '028 discloses sensor 12 as being coupled by diffusion chamber 54 to optical fiber 53 carrying the received, reflected light from light receiving lens tube 51. Ex. 1006, Figure 2, 216-1.

[11c] *“wherein the one or more sensors produce data indicative of a physical position with respect to the object.”*

JP '028 describes the light intensity measurements by the sensor 12 of sample monitor 7 as allowing determination of when the object 40 is at the correct distance L from the colorimeter B for accurate color measurement of light reflected off the surface of the object 40. Ex. 1006, 216-1 to 217-1:

By this, when the relative distance of the machine body 3 and the object to be measured 40 is determined in order for the respective abovementioned optical paths 43, 65, 66 to accumulate at one point on the object to be mentioned 40. . . . . When the light emitted from the respective auxiliary projectors 61, 62 is flashing alternately, at the accumulation x of the projection optical images 65a, 66a (Figure 12), there is never any flashing on and off of any light and only parts separated from each other flash on and off alternately. Subsequently,

the accumulation of the projection optical images 65a, 66a can be clearly demonstrated and setting a minute distance can be carried out easily and accurately. Also, using a filter or the like, if light of different spectral distribution is projected from the respective auxiliary projectors 61, 62, there is a composed image of two colors only on the part x (Figure 13) where the projection images 65a, 66a from the respective auxiliary projectors 61, 62 accumulate on the object to be measured 40 and there is the respective single color on the part where they do not accumulate; as this is demonstrated clearly similar to when the accumulation condition is flashing on and off, it is effective for a minute distance setting. Moreover, the projection position of the two-color light when the object to be measured is closer than the prescribed distance and the projection position of the two-color light when it is farther than the prescribe position turn the light axis of the main projection optical path to a boundary. (cf. Figures 10 & 11). Subsequently, whether the object to be measured is nearer or farther from the prescribed distance can be [perceived] on what color is on which side of the projection image and the adjustment direction becomes clear when setting the distance from the object to be measured. Ex. 1006, 220-l to 220-r.

### C. Charts

<b>Limitation</b>		<b>JP '028</b>
1a	A method for determining optical characteristics of an object, comprising the steps of:	Colorimeter B that implements an algorithm for determining tristimulus color values X, Y, and Z for the color of an object 40. Ex. 1006, Figures 2 & 6, 215-r, 216-l, 219-l, 220-l.
1b	providing light to the object from one or more light sources, and receiving light from the object through one or more light receivers,	Colorimeter B is positioned to receive light from light source 1 that is reflected off object 40. Sample monitor 7 including a sensor 12 measuring light reflected from object 40, carried by an optical fiber 53 from a light receiving lens tube 51 to a diffusion chamber 54 containing sensor 12. Ex. 1006, Figure 2, 215-l, 216-l. Two auxiliary light projectors 61, 62 in the colorimeter B projecting alternately flashing light from a light-emitting diode light source 63 and a xenon light source 1 collectively provide light to object 40 under control of CPU 110 via at least control signal C2 and light emitting circuit 9 and/or auxiliary circuit 86. Ex. 1006, 216-l, Figures 1-2, 215-r, 216-l, 217-l, 216-r, 217-r, 218-l. An optical fiber 53 in colorimeter B receives light reflected from object 40 via light receiving lens 52 in light receiving lens tube 51. Ex. 1006, 216-l, Figure 2, 215-l, 216-l.
1c	wherein the one or more light sources and one or more light receivers define at least one minimal height, wherein below the minimal height, light that is reflected from a surface of the object is not propagated by the one or more light receivers,	Light source 1 emits light 43 focused by projection lens 38. Ex. 1006, Figure 2, 215-r. Auxiliary light emitting diode light sources 63 (or, alternatively, single auxiliary source 100 and optical fibers 61a, 62a) of light projectors 61, 62 each emit light, 65, 66 focused by projection lenses 64. Ex. 1006, Figure 4, 216-l, Figure 14, 217-l. Light 65, 66 intersects light 43 at position S that is a prescribed distance L from the projection lens 38 within the main optical path 43 from light source 1, at which points the light spots coincide with the focal area of light receiving lens 52. Ex.

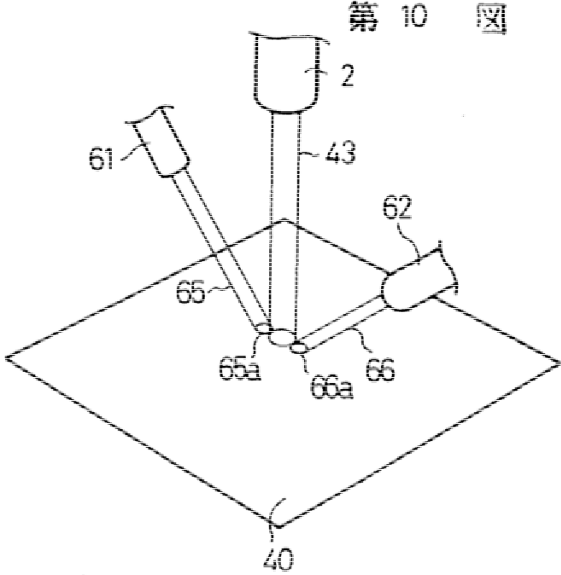
	Limitation	JP '028
		<p>1006, 216-l, 216-r. Below the prescribed distance L, intensity of light within main optical path 43 and of reflected light diminishes. When the surface of object 40 is at some distance less than L, projected light 65a, 66a from the two auxiliary light projectors 61, 62 is not projected onto the focal area of lens 52 and is not received by sensor 12 within sample monitor 7:</p>  <p>Ex. 1006, Figure 10, 216-r. In addition, the columnar cone of light 42 and the inverted cone for focal lens 52 intersect at some point below the prescribed distance L. Ex. 1006, Figure 2. Below that point, even light 43 from the light source 1 is not received by optical fiber 52 connected to light receiving lens tube 51. Ex. 1008, ¶¶ 53-57.</p>
1d	wherein the light is provided to the object and received from the object through a protective barrier having a thickness, wherein the thickness is less than the minimal height;	Projection lens 38 and a light receiving lens 52, through which light source 1 provides light external to the colorimeter and through which sensor 12 receives light reflected off object 40 external to the colorimeter, collectively form a structure that separates the light source 1/optical fiber 53 and the object

<b>Limitation</b>		<b>JP '028</b>
		40 and have a thickness which is within or below the prescribed distance L (the first “minimal height”) to the object surface. Ex. 1006, Figure 2, 215-r, 216-l; Ex. 1008, ¶¶ 55-59.
1e	measuring the intensity of light received and propagated by one of the one or more light receivers;	Detectors D <sub>1</sub> '-D <sub>n</sub> ' in sensor 12 of sample monitor 7 measure light intensity for the basic color components of reflected light received via optical fiber 53. Ex. 1006, 217-r, 218-l.
1f	determining the optical characteristics of the object based in response to one or more intensity measurements.	Tristimulus color values X, Y, and Z are calculated based on digital sample monitor data MS(i) of color light intensities measured by the sensor 12 of sample monitor 7 divided by digital light source monitor data MR(i) of color light intensities measured by the sensor 11 in light source monitor 5. Ex. 1006, 219-l, 219-r.
3a	The method of claim 1,	See [1a]-[1f].
3b	wherein at least one measurement is taken below the minimal height.	Figure 10 depicts a light intensity measurement taken with the colorimeter positioned a distance from the object surface that is less than the prescribed distance L. Ex. 1006, Figure 10. At that position below the prescribed distance L, the light spots 65a and 66a from the auxiliary projectors do not coincide with the light spot from the main optical path 43 or with the focal point of light receiving lens 52. Ex 1006, 216-r; Ex. 1008, ¶¶ 53-57.
11a	The method of claim 1,	See [1a]-[1f].
11b	wherein one or more sensors are coupled to the one or more light receivers,	Sensor 12 is coupled by diffusion chamber 54 to optical fiber 53 carrying the received, reflected light from light receiving lens tube 51. Ex. 1006, Figure 2, 216-l.
11c	wherein the one or more sensors produce data indicative of a physical position with respect to the	Digital sample monitor data MS(i) of color light intensities measured by the sensor 12 of sample monitor 7 are divided by digital light source monitor data MR(i) of color light

Limitation	JP '028
object.	intensities measured by the sensor 11 in light source monitor 5 to derive ANS(i) data. Ex. 1006, 219-r. The color light intensity measurements allow determination of when the object 40 is at the correct distance L for accurate color measurement of light reflected off the surface of the object 40. Ex. 1006, 216-l to 217-l. When projected light 65a, 66a coincides with main optical path 43, the object 40 is at the prescribed distance. Ex. 1006, 218-l to 218-r. When flashing light of two different colors is projected by auxiliary projectors 61, 62, the overlap and the position of different colors allows determination of when the object is not at prescribed distance L and the direction in which the object 40 is offset from the prescribed distance L. Ex. 1006, Figures 12-13, 218-r.

**VIII. GROUND 3: Claims 1, 3 and 11 of the '541 Patent are obvious over Mills.**

This ground is not redundant with Grounds 1-2 because Mills explicitly describes an apparatus operating according to 511's interpretation of "minimal height," which is intrinsic to the references of Grounds 1-2.

**A. Overview of Mills**

Mills discloses an optical scanning unit 18 with a detector subsystem 22 for determining characteristics of fruit 10 (e.g., a lemon), including color, surface blemishes, size, and shape based on light reflected off the surface of the fruit:

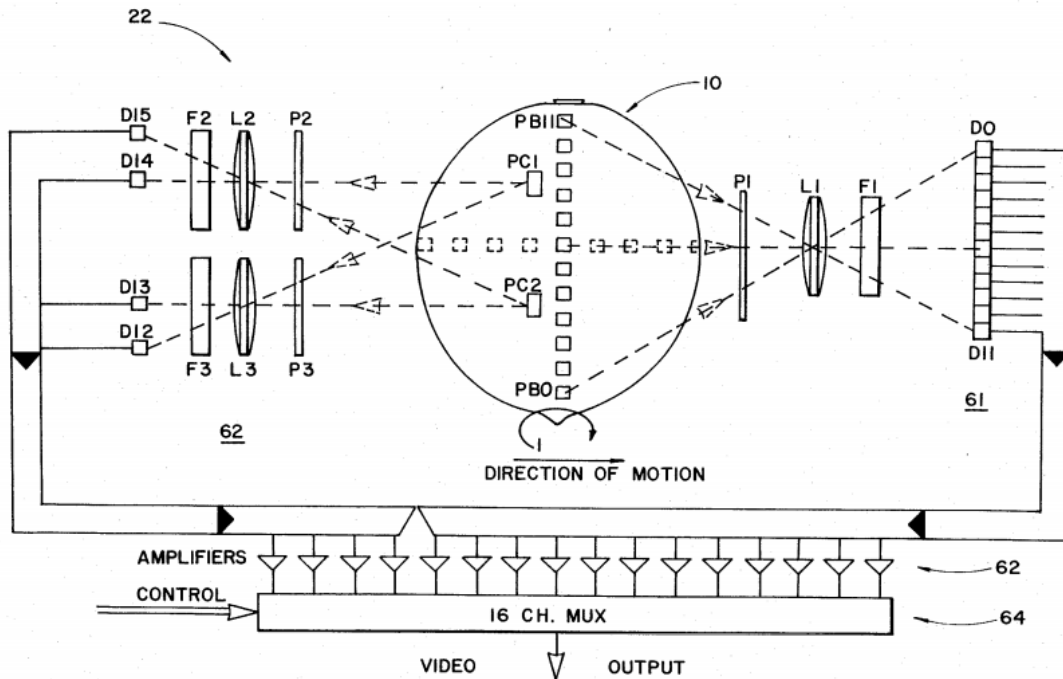

Fig. 3

Ex. 1007, Figure 3, 1:5-9, 2:17-22; 2:45-64, 3:47 to 4:26, 7:4-39; see also Figs. 1-2, 5, 6A-6B.

**B. Mills Renders Claims 1, 3 and 11 Obvious**

1. *Claim 1*

[1a] “A method for determining optical characteristics of an object, comprising the steps of:”

Mills describes an apparatus operable for sorting fruit “as a function of variables including color.” Ex. 1007, Abstract. Color is an optical characteristic of an object.



[1b] *“providing light to the object from one or more light sources, and receiving light from the object through one or more light receivers,”*

Each scanning unit 18 is positioned over a fruit 10 on rollers 14 of one conveyor 12. Ex. 1007, Figures 1 & 2A-2B, 3:29-46. The scanning unit is positioned in sufficient proximity to fruit 10 for diodes D0-D11 therein to receive light reflected off the fruit surface portions PB0-PB11 and diodes D12-D15 therein to receive light reflected off the fruit surface portions PC1-PC2. Ex. 1007, 5:15-18, 5:61-6:8. Each scanning unit 18 includes a lamp 56 providing illumination reflected by four illuminators 20 onto the upper fruit surface:

*Fig. 2B*

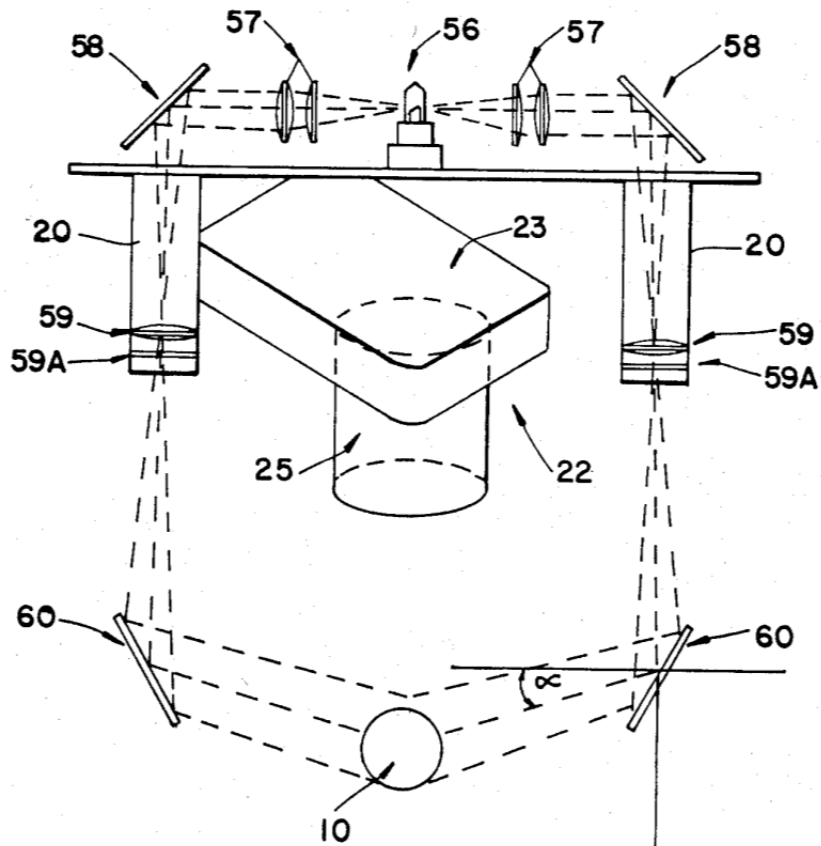

Ex. 1007, Figure 3, 4:27-66. The detector 22 in each scanning unit 18 receives light reflected from fruit via a cylindrical housing of lens portion 25. Ex. 1007, Figure 2B & 3, 4:67-68, 5:5-18, 5:68-6:8. The cylindrical housing (“light receiver”) restricts the angle of acceptance for diodes D0-D15 in the sensor portion 23, and is functionally equivalent to fiber optics in that regard. Ex. 1008, ¶ 35. Each scanning unit 18 is a device used for measuring reflected light or obtaining information regarding fruit 10.

[1c] “wherein the one or more light sources and one or more light receivers define at least one minimal height, wherein below the minimal height, light that is reflected from a surface of the object is not propagated by the one or more light receivers,”

Each detector 22 receives light from lamp 56 reflected off the upper fruit surface via a lens portion 25:

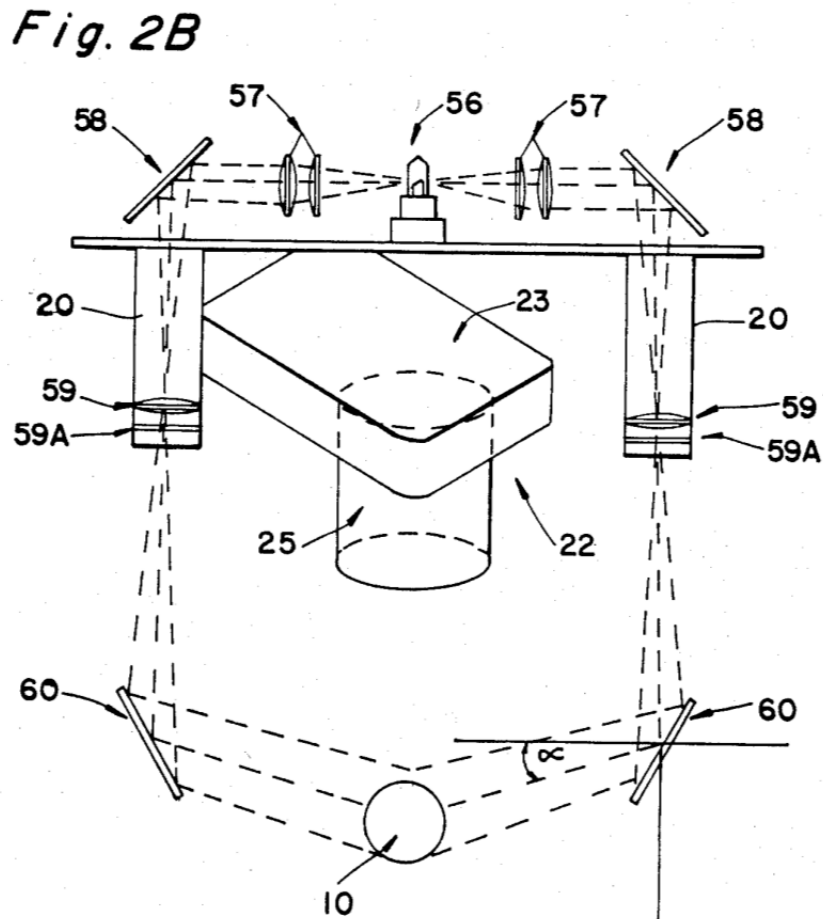

Ex. 1007, Figure 2B, 4:67-68. Diodes D0-D15 in the sensor portion 23 of each detector 22 receive light reflected off the upper fruit surface via cylindrical housing of lens portion 25. Ex. 1007, Figures 2B & 3, 4:67-68, 5:15-18, 5:68-6:8. Each

illuminator 20 projects light reflected by mirrors 60 toward the fruit 10 at an incident angle  $\alpha$  in the range of 15°-45° below horizontal. Ex. 1007, Figure 2B, 4:34-43. The light paths from mirrors 60 onto fruit determine a minimal height between the upper fruit surface and the diodes D0-D15 in sensor portion 23. Ex. 1008, ¶¶ 36-38. When upper fruit surface is less than that minimal height (i.e., closer to diodes D0-D15), it will be outside the light paths from mirrors 60 depicted in Figure 2B and defined by the incident angles described. Ex. 1008, ¶¶ 36-38. As a result, light from lamp 56 (directed toward fruit 10 by mirrors 60) will not be reflected off the upper fruit surface or received and propagated by the cylindrical housing to diodes D0-D15. Ex. 1008, ¶¶ 36-38.

[1d] *“wherein the light is provided to the object and received from the object through a protective barrier having a thickness, wherein the thickness is less than the minimal height;”*

Each illuminator 20 includes a projection lens 59 through which light illuminating the fruit passes, and each detector 22 includes lenses L1-L3 through which light reflected from the fruit passes prior to impinging on diodes D12-D15. Ex. 1007, Figures 2A-B and 3, 4:27-5:32. Lenses 59 and L1-L3 form a transparent member. Lenses 59 and L1-L3 each have a thickness, depicted in Mills as less than the length of lens portion 25 between diodes D0-D15 and fruit 10 and as

within the minimal distance between the diodes D0-D15 and fruit 10. Ex. 1016, Figure 2B; Ex. 1008, ¶¶ 36-38.

[1e] *“measuring the intensity of light received and propagated by one of the one or more light receivers;”*

Diodes D0-D15 measure an intensity of light reflected off the fruit 10 and received and propagated by the cylindrical housing, producing byte-length data values for the light intensity measurements. Ex. 1007, Figure 4, 6:9-19, 6:25-28.

[1f] *“determining the optical characteristics of the object based in response to one or more intensity measurements.”*

The byte-length data values for light intensity measurements by diodes D12-D15 are passed to scanning unit microcomputer 66 and master processor microcomputer 72 for color and variegation calculations. Ex. 1007, Figures 6A-6B, 7:4-39, 7:45 to 8:21, 7:17-28, 9:50 to 10:8.

2. *Claim 3:*

[3b] *“wherein at least one measurement is taken below the minimal height.”*

The diodes D0-D15 are operable to take light intensity measurements even if the upper fruit surface outside the light paths from mirrors 60 depicted in Figure 2B and defined by the incident angles described, and closer to the diodes D0-D15 than the minimal height defined by those light paths. Ex. 1008, ¶¶ 36-38.

3. *Claim 11:*

[11b] *“wherein one or more sensors are coupled to the one or more light receivers,”*

Diodes D0-D15 in the sensor portion 23 of each detector 22 receive light from the lenses L1-L3 in the lens portion 25, through filters F1-F3 and polarizers P1-P3. Ex. 1007, Figures 2B & 3, 4:67-68, 5:15-18, 5: 23-26, 5:65-6:8.

[11c] *“wherein the one or more sensors produce data indicative of a physical position with respect to the object.”*

The byte-length data for light intensity measurements by diodes D0-D11 indicate a position (of the diodes D0-D11) relative to the upper fruit surface regions PB0-PB11, such that the leading and trailing edges of the fruit and indentations on the fruit surface are determined. Ex. 1007, Figures 3-4, 5:15-18, 6:32-53; Ex. 1008, ¶¶ 36-38.

**C. Charts**

	<b>Limitation</b>	<b>Mills</b>
1a	A method for determining optical characteristics of an object, comprising the steps of:	Mills describes an apparatus operable for sorting fruit “as a function of variables including color.” Ex. 1007, Abstract.
1b	providing light to the object from one or more light sources, and receiving light from the object through one or more light receivers,	Each scanning unit 18 is positioned over a fruit 10 on rollers 14 of one conveyor 12. Ex. 1007, Figures 1 & 2A-2B, 3:29-46. The scanning unit is positioned in sufficient proximity to fruit 10 for diodes D0-D11

	<b>Limitation</b>	<b>Mills</b>
		<p>therein to receive light reflected off the fruit surface portions PB0-PB11 and diodes D12-D15 therein to receive light reflected off the fruit surface portions PC1-PC2. Ex. 1007, 5:15-18, 5:61-6:8. Each scanning unit 18 includes a lamp 56 providing illumination reflected by four illuminators 20 onto the upper fruit surface. Ex. 1007, Figure 3, 4:27-66. The detector 22 in each scanning unit 18 receives light reflected from fruit via a cylindrical housing of lens portion 25. Ex. 1007, Figure 2B &amp; 3, 4:67-68, 5:5-18, 5:68-6:8. The cylindrical housing (“light receiver”) restricts the angle of acceptance for diodes D0-D15 in the sensor portion 23, and is functionally equivalent to fiber optics in that regard. Ex. 1008, ¶ 36.</p>
1c	<p>wherein the one or more light sources and one or more light receivers define at least one minimal height, wherein below the minimal height, light that is reflected from a surface of the object is not propagated by the one or more light receivers,</p>	<p>Each detector 22 receives light from lamp 56 reflected off the upper fruit surface via a lens portion 25. Ex. 1007, Figure 2B, 4:67-68. Diodes D0-D15 in the sensor portion 23 of each detector 22 receive light reflected off the upper fruit surface via cylindrical housing of lens portion 25. Ex. 1007, Figures 2B &amp; 3, 4:67-68, 5:15-18, 5:68-6:8. Each illuminator 20 projects light reflected by mirrors 60 toward the fruit 10 at an incident angle <math>\alpha</math> in the range of 15°-45° below horizontal. Ex. 1007, Figure 2B, 4:34-43. The light paths from mirrors 60 onto fruit determine a minimal height between the upper fruit surface and the diodes D0-D15 in sensor portion 23. Ex. 1008, ¶¶ 36-38. When upper fruit surface is less than that minimal height (i.e., closer to diodes D0-D15), it will be outside the light paths from mirrors 60 depicted in Figure 2B and defined by the incident angles described. Ex. 1008, ¶¶ 36-38. As a result, light from lamp 56 (directed</p>

<b>Limitation</b>		<b>Mills</b>
		toward fruit 10 by mirrors 60) will not be reflected off the upper fruit surface or received and propagated by the cylindrical housing to diodes D0-D15. Ex. 1008, ¶¶ 36-38.
1d	wherein the light is provided to the object and received from the object through a protective barrier having a thickness, wherein the thickness is less than the minimal height;	Each illuminator 20 includes a projection lens 59 through which light illuminating the fruit passes, and each detector 22 includes lenses L1-L3 through which light reflected from the fruit passes prior to impinging on diodes D12-D15. Ex. 1007, Figures 2A-B and 3, 4:27-5:32. Lenses 59 and L1-L3 form a transparent member. Lenses 59 and L1-L3 each have a thickness, depicted in Mills as less than the length of lens portion 25 between diodes D0-D15 and fruit 10 and as within the minimal distance between the diodes D0-D15 and fruit 10. Ex. 1016, Figure 2B; Ex. 1008, ¶¶ 36-38.
1e	measuring the intensity of light received and propagated by one of the one or more light receivers;	Diodes D0-D15 measure an intensity of light reflected off the fruit 10 and received and propagated by the cylindrical housing, producing byte-length data values for the light intensity measurements. Ex. 1007, Figure 4, 6:9-19, 6:25-28.
1f	determining the optical characteristics of the object based in response to one or more intensity measurements.	The byte-length data values for light intensity measurements by diodes D12-D15 are passed to scanning unit microcomputer 66 and master processor microcomputer 72 for color and variegation calculations. Ex. 1007, Figures 6A-6B, 7:4-39, 7:45 to 8:21, 7:17-28, 9:50 to 10:8.
3a	The method of claim 1,	See [1a]-[1f].
3b	wherein at least one measurement is taken below the minimal height.	The diodes D0-D15 are operable to take light intensity measurements even if the upper fruit surface outside the light paths from mirrors 60 depicted in Figure 2B and defined by the incident angles described, and closer to the



<b>Limitation</b>		<b>Mills</b>
		diodes D0-D15 than the minimal height defined by those light paths. Ex. 1008, ¶¶ 36-38.
11a	The method of claim 1,	See [1a]-[1f].
11b	wherein one or more sensors are coupled to the one or more light receivers,	Diodes D0-D15 in the sensor portion 23 of each detector 22 receive light from the lenses L1-L3 in the lens portion 25, through filters F1-F3 and polarizers P1-P3. Ex. 1007, Figures 2B & 3, 4:67-68, 5:15-18, 5: 23-26, 5:65-6:8.
11c	wherein the one or more sensors produce data indicative of a physical position with respect to the object.	The byte-length data for light intensity measurements by diodes D0-D11 indicate a position (of the diodes D0-D11) relative to the upper fruit surface regions PB0-PB11, such that the leading and trailing edges of the fruit and indentations on the fruit surface are determined. Ex. 1007, Figures 3-4, 5:15-18, 6:32-53; Ex. 1008, ¶¶ 36-38.

## IX. CONCLUSION

Claims 1, 3 and 11 of the '541 Patent are unpatentable as obvious. Petitioner therefore requests *inter partes* review on Grounds 1-3 as well as cancelation of those claims.

Dated: September 14, 2016

Respectfully submitted,

By: /Daniel E. Venglarik/  
Daniel E. Venglarik  
Registration No. 39,409  
MUNCK WILSON MANDALA, LLP  
12770 Coit Road, Suite 600  
Dallas, TX 75251-1360  
(972) 628-3600

**CERTIFICATE OF SERVICE UNDER 37 C.F.R. §§ 42.6(e)(4) and 42.105**

The undersigned certifies that a copy of the foregoing PETITION FOR INTER PARTES REVIEW and all exhibits identified herein are being served via Priority Mail Express on September 14, 2016 on:

Alan R. Loudermilk  
511 N. Washington Ave  
Marshall, TX 75670

Paresh Patel, President  
511 Innovations Inc.  
511 N. Washington Ave  
Marshall, TX 75670

Russell W. Jung, Chief Operating Officer  
JLJ Technologies LLC  
9023 N. Menard  
Morton Grove, IL 60053

William Ellsworth Davis, III  
The Davis Firm, PC  
213 North Fredonia Street, Suite 230  
Longview, TX 75601

Dated: September 14, 2016

/Daniel E. Venglarik/  
Daniel E. Venglarik  
Registration No. 39,409

**CERTIFICATE OF WORD COUNT UNDER 37 C.F.R. §§ 42.24(d)**

The undersigned certifies that the word count of the foregoing PETITION FOR INTER PARTES REVIEW, starting with the “OVERVIEW OF CHALLENGE AND RELIEF REQUESTED” up to and including the last word of the “CONCLUSION,” is 9,814.

Dated: September 14, 2016

/Daniel E. Venglarik/  
Daniel E. Venglarik

702397.