

H.W. #8 EE 420/ECG 620 Spring 2020

Show your work for credit and put a box around each of your answers (follow the hw guidelines!) Unless otherwise indicated use the book's long-channel (1 μm) process.

1. Hand calculate the DC currents and voltages in the following circuit. Show, similar to Eq. (20.23), how to derive an equation for the currents flowing in M4 and M1. Compare your hand calculated values to LTspice simulations and then comment on the differences. Note that M3 has $m=4$ (four devices in parallel, i.e., effectively $W=120\mu$). (4 points)

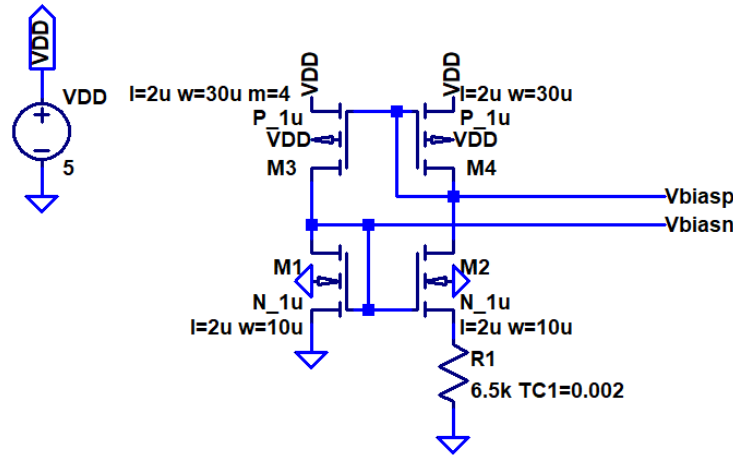

2. Show, using a transient simulation, how the circuit in problem 1, above, can operate with no current flowing (it's okay to use initial conditions in the simulation). Next, design a start-up circuit to eliminate this possibility. Verify your design using LTspice. (2 points)
3. Show how to add an amplifier, with a topology seen in Fig. 20.21 (you'll need to select sizes appropriate for the long channel process) to the bias circuit in problem 1 to reduce the variations in the current flowing in the circuit with changes in VDD. Simulate your design and show the improved performance (more constant currents with varying VDD). (4 points)