

H.W. #18 EE 420/ECG 620 Spring 2020

Show your work for credit and put a box around each of your answers (follow the hw guidelines!) Unless otherwise indicated use the book's long-channel (1 μ m) process.

1. Estimate, using simulations, the change in the below Schottky diode's voltage drop with temperature. (2 points)

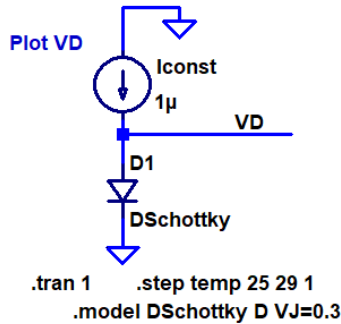

2. Estimate, using hand calculations, the reference voltage and reference voltage's temperature coefficient in the following circuit. Compare your answer to an LTspice simulation. (4 points)

