

H.W. #16 EE 420/ECG 620 Spring 2020

Show your work for credit and put a box around each of your answers (follow the hw guidelines!) Unless otherwise indicated use the book's long-channel (1 μm) process.

1. Estimate the frequency response of the following circuit. Verify your answer using LTspice. (3 points)

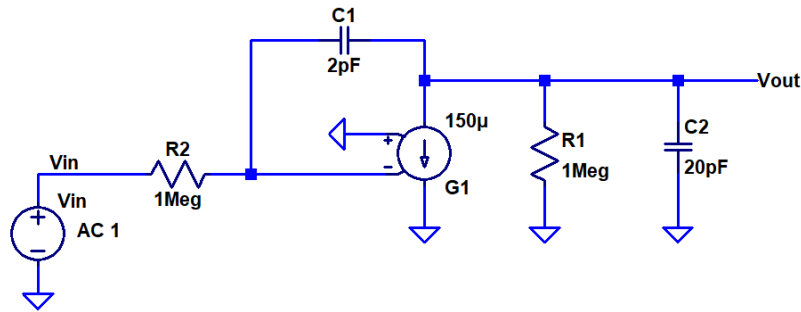

2. Label all DC operating voltages in the following circuit including those coming out of the Fig_20_43 biasing block. What is the range of the output swing assuming all transistors remain in the saturation region? Estimate the low-frequency gain of the following circuit, V_{out}/V_s . Estimate the gain from V_s to the drain of M1. Verify your answers using LTspice (4 points)

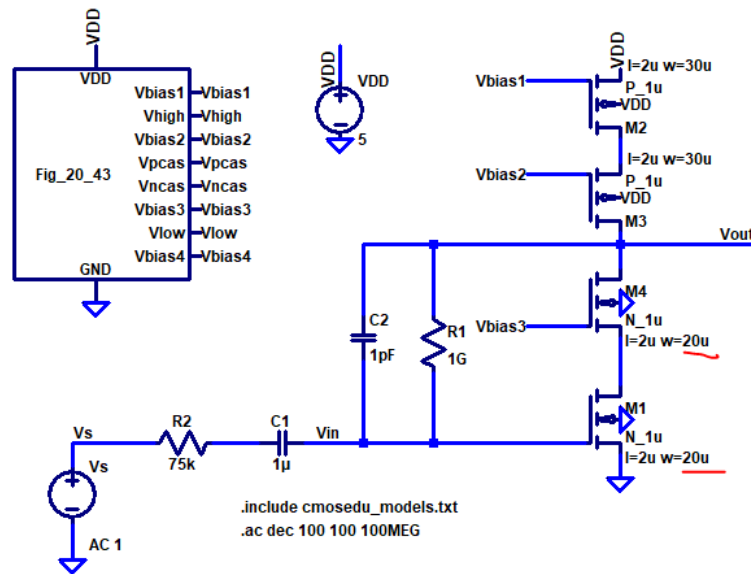

3. Estimate the frequency response of the amplifier in problem 2. Verify your estimate using LTspice. (3 points)