

H.W. #14 EE 420/ECG 620 Spring 2020

Show your work for credit and put a box around each of your answers (follow the hw guidelines!) Unless otherwise indicated use the book's long-channel (1 μm) process.

- Determine the AC and DC currents and voltages in the following SF amplifier. Also determine the allowable range of input voltages, V_s . Verify your hand calculations using LTSpice (3 points)

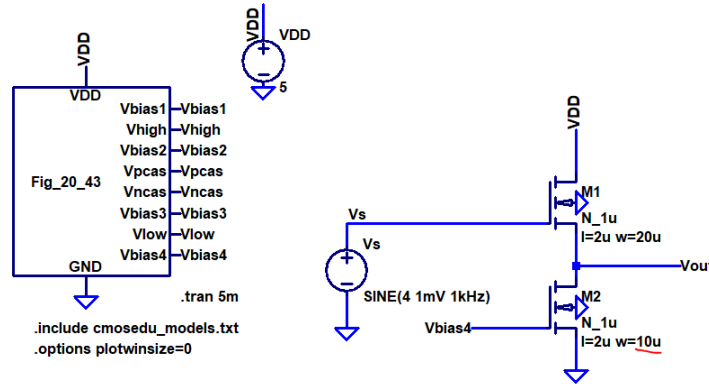

- Repeat problem 1 for the following SF amplifier. (3 points)

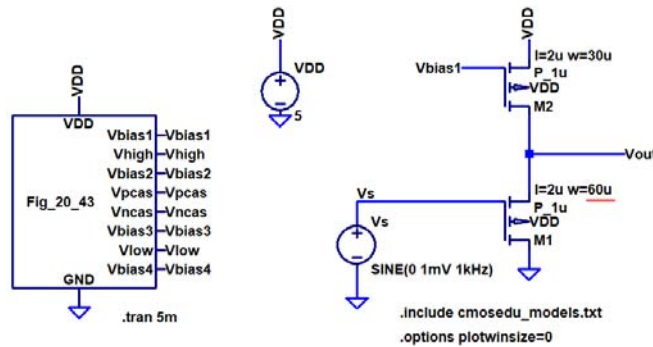

- Determine the gains of the following CG amplifiers. (4 points)

