

H.W. #15 EE 420/ECG 620 Spring 2019

Show your work for credit and put a box around each of your answers (follow the hw guidelines!) Unless otherwise indicated use the book's long-channel (1 μm) process.

- Use the following circuits to explain, in your own words and using LTspice simulations, Miller's theorem. (3 points)

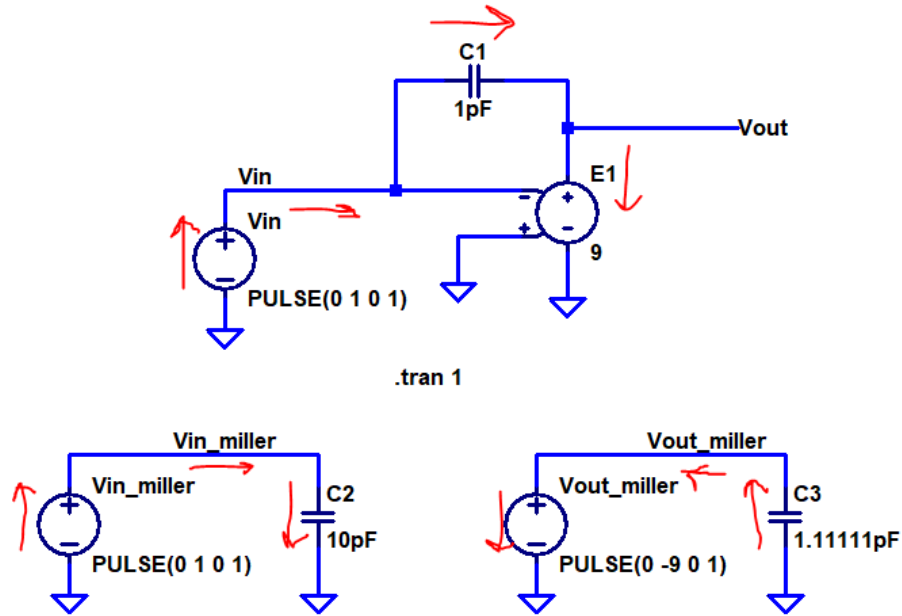

- Estimate the frequency response of the following amplifier. Verify your hand calculations using LTspice (4 points)

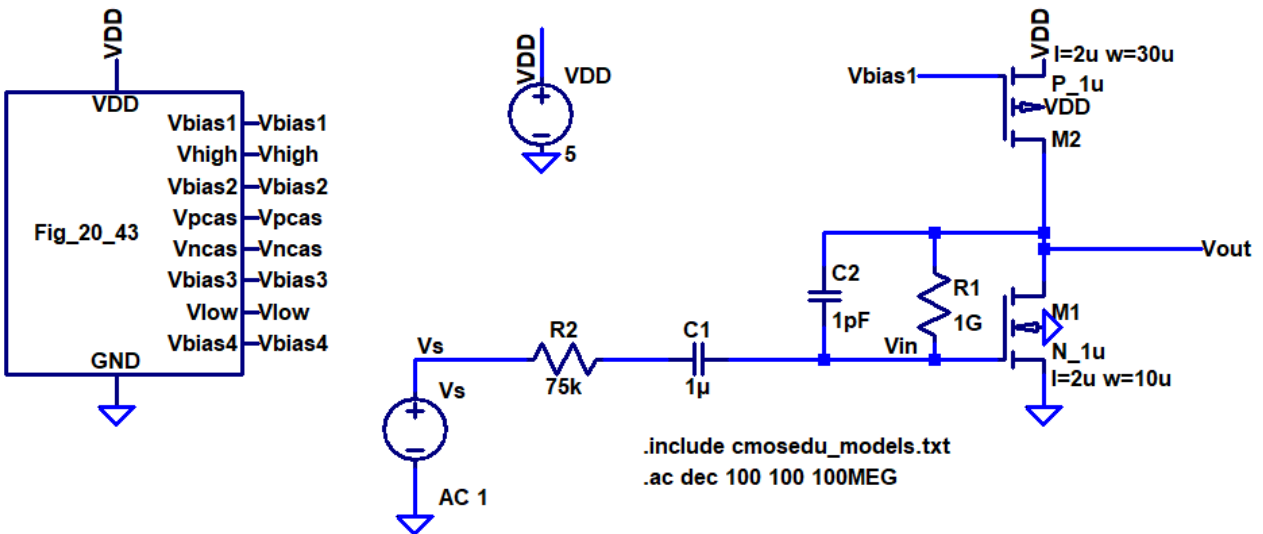

- Repeat problem 2 if a 10 pF load is connected to Vout. (4 points)