

H.W. #9 EE 221 Spring 2023

Show your work for credit and put a box around each of your answers (follow the hw guidelines!)

- Estimate the current, and thus effective resistance, connected to VP1, VP2, and VP3 in the following circuit if the Delta circuit (only) is connected to the three-phase input. Repeat when the Y circuit (only) is connected to the three-phase input. Use LTspice to confirm your hand calculations. (3 points each)

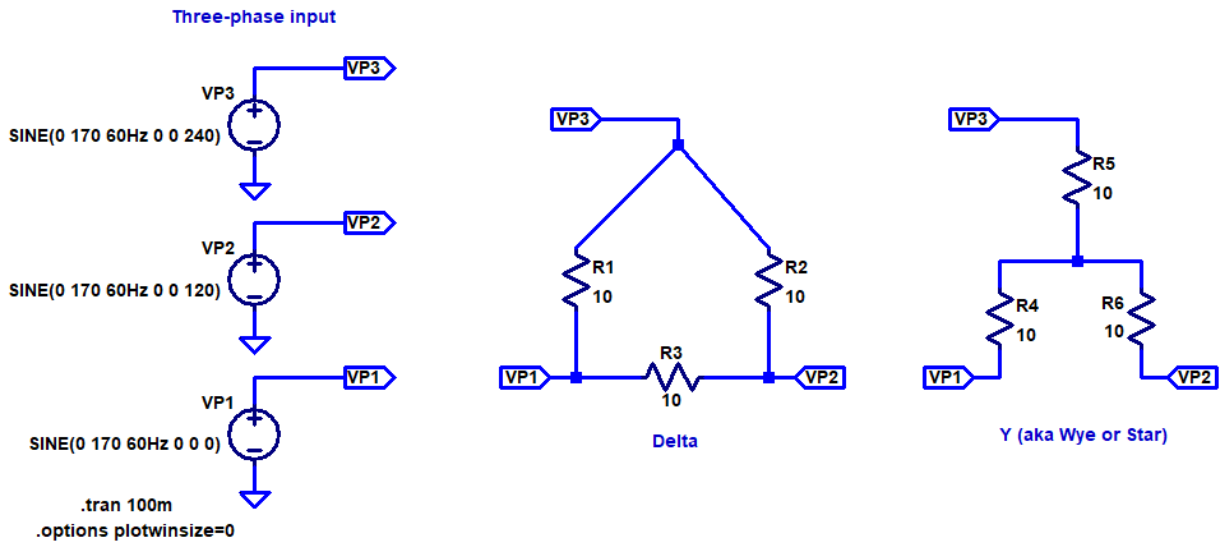

- For each of the circuits seen below determine the apparent power ($I_{RMS}V_{RMS}$) dissipated by the resistor. Verify your answer using LTspice. (8 points)

