

H.W. #4 EE 221 Spring 2023

Show your work for credit and put a box around each of your answers (follow the hw guidelines!)

- Find both the Thevenin and Norton equivalent circuits for each of the following circuits at the terminals (red) indicated. Attach a 1k resistor across the terminals and show that your Thevenin and Norton equivalents output a voltage that matches what you get with the original circuit. Verify your answers using LTspice (a total of twelve simulations: 1 each for each of the original circuits driving a 1k resistor (4 simulations) and then show that you get the same results with your Thevenin equivalent driving the 1k (4 simulations) and your Norton equivalent driving the 1k (4 simulations)). Be as concise and clear as possible while still showing your work. (12 points)

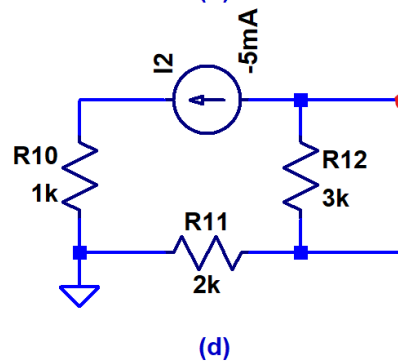
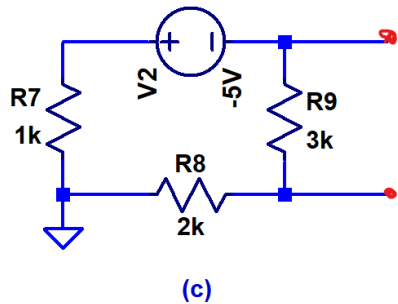
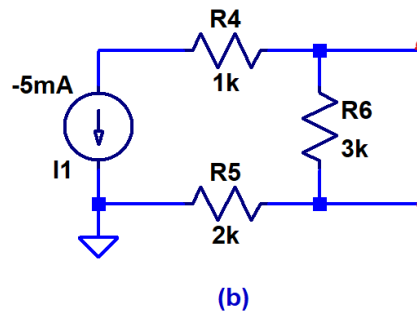
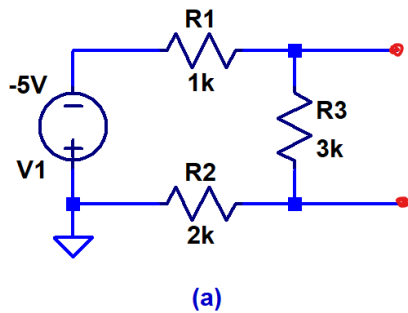

- Find V_X and V_Y in each of the following circuits using any method you would like. Verify your answers using LTspice. (4 points)

