

H.W. #12 EE 221 Spring 2023

Show your work for credit and put a box around each of your answers (follow the hw guidelines!)

- Hand calculate V_c and V_r in the following circuit. Compare your hand calculations to simulation results. Note that the switch closes at 200 ns. Make sure you understand how to use switches since we'll use them often. (2 points)

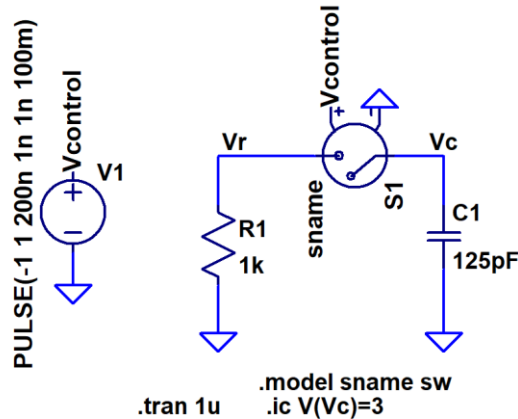

- Write the equation describing the voltage across the capacitor in the following circuit. Use LTspice to verify your answer. (2 points)

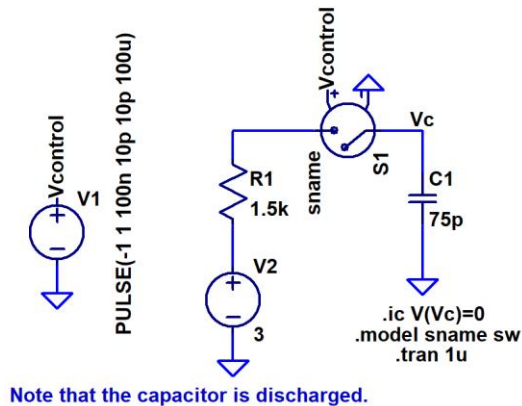

- Write the equations describing the voltage across the capacitor, V_c , in the following circuits for both the rising and falling edges of the input pulse. Again, use LTspice to verify your answer. (4 points)

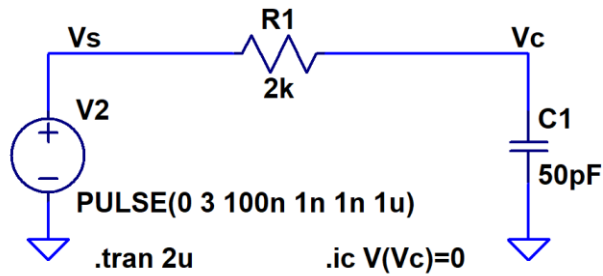

- Repeat problem 3 if the resistor and capacitor positions are swapped. (4 points)