

Practice Final Exam – EE 221 Circuits II  
University of Nevada, Las Vegas

NAME: \_\_\_\_\_

Closed book and notes. No extra paper, do your work on this exam, use the back if needed.  
**Show your work for credit and be neat! Place a box around each of your answers.** No Laplace transform table is allowed or (again) any other extra material (scratch paper).

1. Find  $V_L$  (an equation that includes the input current pulse's delay) in the following circuit using the Laplace transform. Sketch  $V_L$  from 0 to 1  $\mu$ s ensuring you label the axis. (15 points)

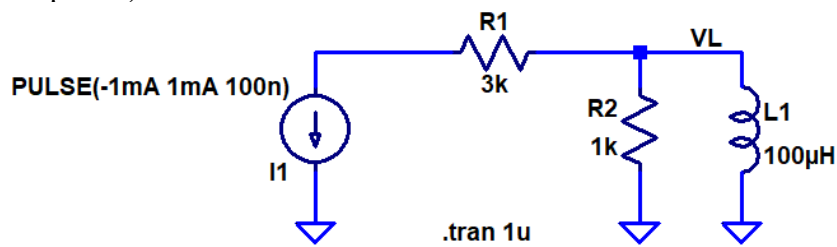

2. Assuming the circuit seen below is operating in steady-state, use AC analysis to determine  $V_{out}$ . Sketch  $V_{out}$  and  $V_{in}$  on the same plot ensuring to label times (phase shift) and voltages. (15 points)

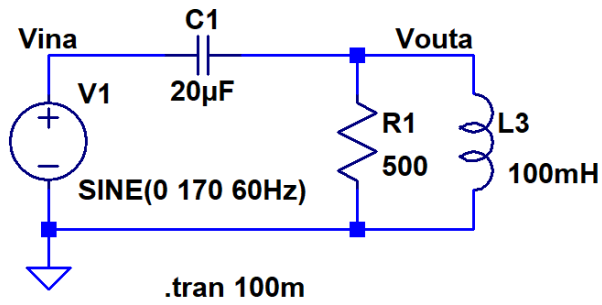

3. Determine the transfer function ( $V_{out}/V_{in}$ ) of the circuit in problem 2 and then determine the (magnitude and phase) frequency responses. Sketch the frequency responses and discuss, using numbers, how your results in problem 2 are correct. (20 points)

4. What is the mutual inductance between L1 and L2 in the circuit seen below? What is the AC power delivered to R1? As always put a box around each of your answers and show your work. (15 points)

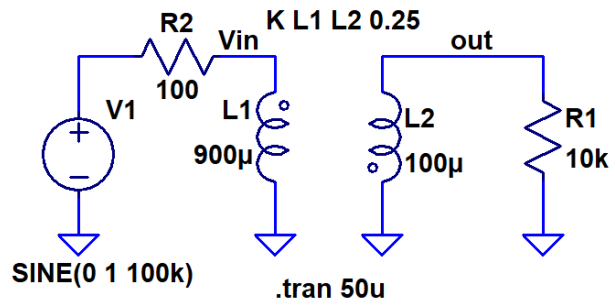

5. Using the Laplace transform show how to find the current through L1 in the following circuit. Ensure you place a box around your answer (the equation in the time domain you've derived using the Laplace transform). Plot this current in the time domain. (15 points)

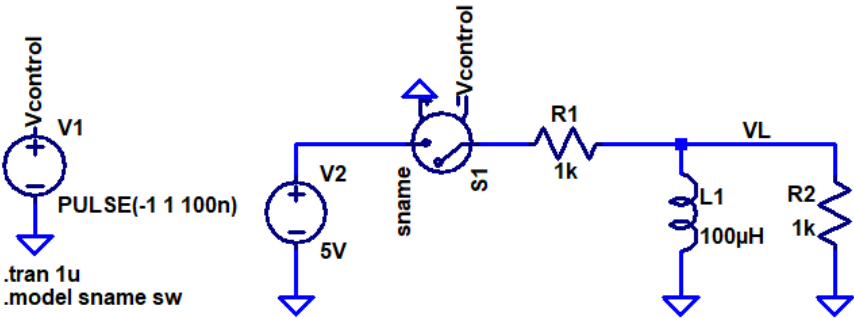

6. Determine the frequency when the output voltage is 1V peak in the following integrator circuit. Again, show your work and place a box around your answer. (20 points)

