

Show your work for credit and put a box around each of your answers (follow the hw guidelines!)

- Examine the circuit seen below. The input is a 3-phase voltage, that is, the voltages VP1, VP2, and VP3 are at the same amplitude and frequency but spaced apart by 120 degrees. Assuming the left side of the sense resistor, Rsense, is at ground (show this is a good assumption), determine the current that flows in each of the 10 ohms resistors (note that this is trivial if you know ohms law). Then determine the current that flows in the sense resistor by summing the currents in each 10 ohm resistor. You should find that the current in the sense resistor is zero. *This is important* and the key reason 3-phase is used in factories, and elsewhere, that is, three phase currents can deliver constant power to a load. Show this by showing the sum of the power dissipated by the resistors is constant. Verify your hand calculations using LTspice. (4 points)

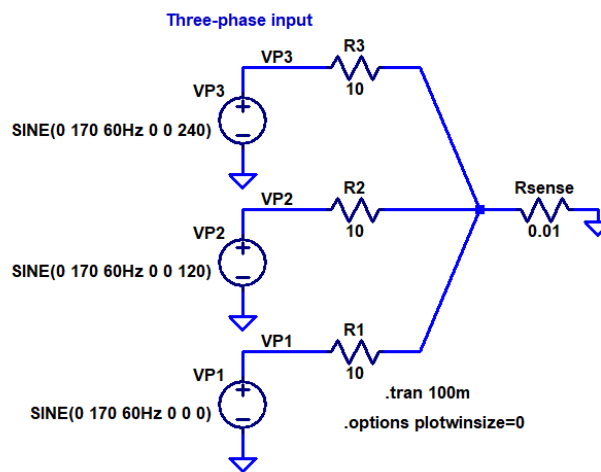

- Find the output voltage for each of the following circuits using AC analysis (as always make sure that your hand calculations are concise and clear). Sketch the output voltage and input voltage on the same plot in the time domain and compare to LTspice. Since AC analysis is for steady-state operation neglect the start-up transients and any DC offsets (i.e. just look at the sinusoids). (8 points)

