

H.W. #6 EE 220 Spring 2017

Show your work for credit!

- Find the voltages and currents in each of the following circuits **using mesh analysis**. Verify your hand calculations using LTspice. (8 points)

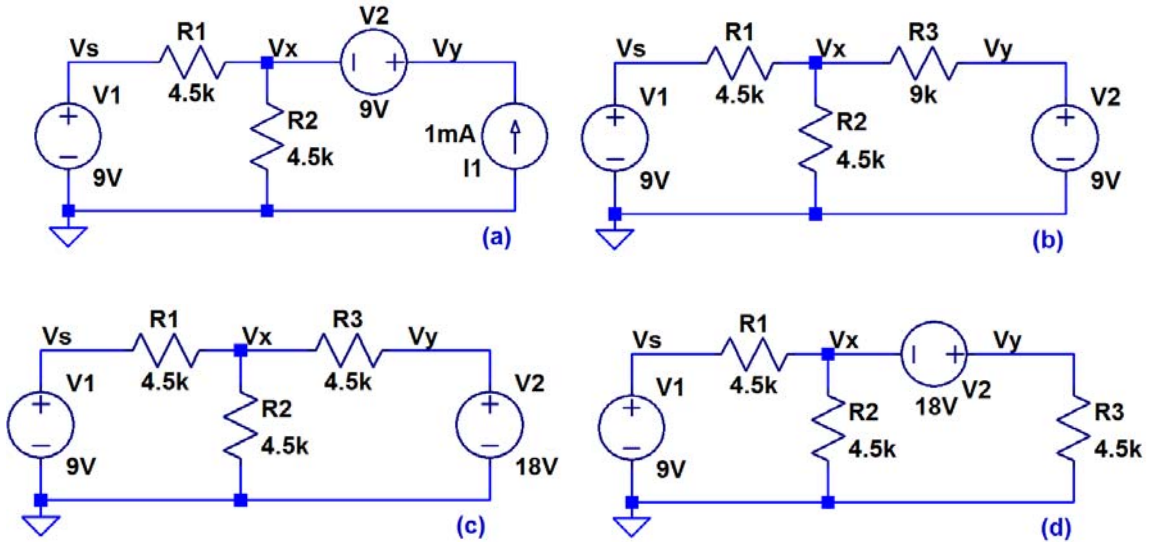

- Repeat problem 1, but no need to repeat the LTspice simulations, **using superposition**. (8 points)
- Find the Thevenin and Norton equivalent circuits for the circuitry to the left of the two terminals marked with red dots below. Show that V_{out} is the same for: 1) the circuit seen below, 2) the Thevenin equivalent circuit connected to R_3 and 3) the Norton equivalent circuit connected to R_3 . Verify your answers with three LTspice simulations. (3 points)

