

H.W. #23 EE 220 Fall 2023

Show your work for credit!

1. Determine, using phasor analysis, the current that flows in the circuits from HW #21, problem 3, and plot along with V_{in} in the time-domain. Use LTspice to verify your hand calculations and plots. (4 points)
2. Determine, using phasor analysis, the current that flows in the circuits from HW #22, problem 2, and plot along with V_{in} in the time-domain. Use LTspice to verify your hand calculations and plots. (4 points)
3. Determine, using phasor analysis, V_{out} in the following integrator circuit. Note that the 100k resistor is used to ensure the DC gain of the integrator isn't infinite. The 100k can be neglected (remove from the circuit) in the phasor (or AC) analysis because its impedance is much larger than the impedance of the capacitor at 500 Hz. Sketch V_{out} and V_{in} on the same plot in the time-domain. Verify your hand calculations and plots with LTspice. (3 points)

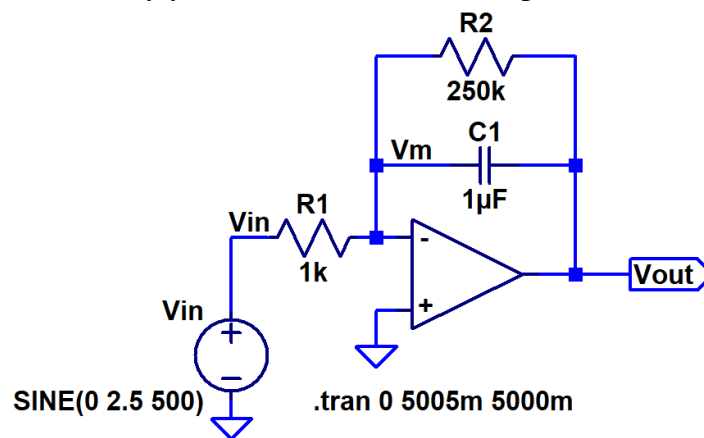

4. Calculate the RMS value of a square wave that oscillates between $-V_p$ and $+V_p$. Assume the square wave has a 50% duty cycle, that is, it is at $+V_p$ the same amount of time it is at $-V_p$. (3 points)