

Show your work for credit!

- Calculate the voltage across R_4 in the below circuits. Next find the Thevenin and Norton equivalent circuits at the port indicated by the red dots in the below schematics (without R_4 in the circuit). Show that your equivalent circuits are correct and then verify with LTspice. (6 points)

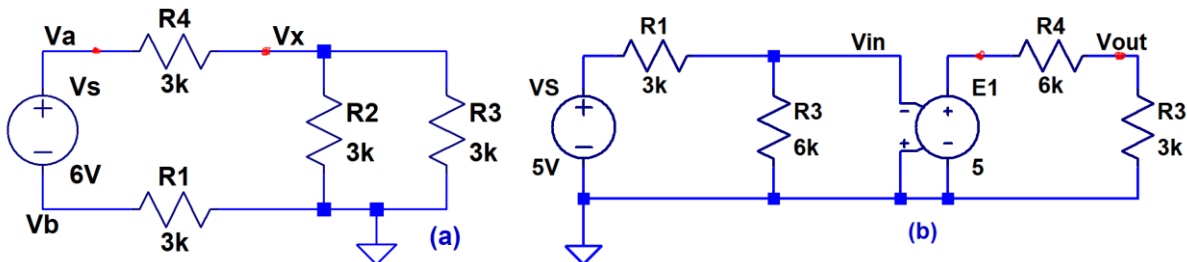

- Find the voltage V_B in the following circuit. Verify your answer with LTspice. (3 points)

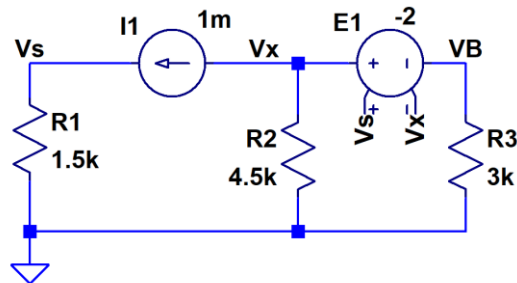

- Find V_{out} in the following circuit. For all intents and purposes you can assume the gain of the VCVS is infinite. (3 points)

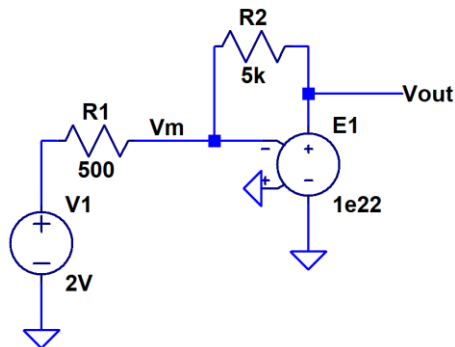

- Find V_{out} in the following circuit. Verify your answer with LTspice. As always, show your work for credit. (2 points)

