

Show your work for credit!

- In the circuit to the right, the voltage on C1, before the switch closes, is 1 V while the voltage on C2 is 0.5 V. What is the voltage on C1/C2 after the switch closes? What is the energy stored in each capacitor before the switch closes? What is the energy stored in the capacitors after the switch closes? Since capacitors don't dissipate power why doesn't the energy stored in the capacitors before the switch closes equal the energy stored across the capacitors after the switch closes. Note that this is called *charge sharing* and is used in dynamic random access memory (DRAM, your computer's memory). Does the switches resistance of 1kΩ influence your answer? (4 points)

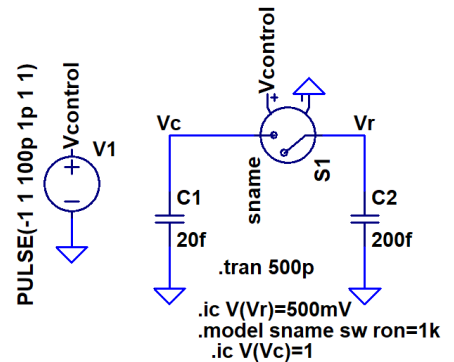

- Plot the output of the following circuit from a time 0 to 10 ms. Assume the capacitor is initially discharged (both sides are at ground). Show your hand calculations for credit. Verify your plot with LTspice. (3 points)

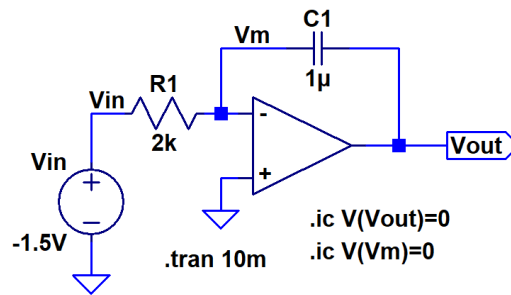

- Repeat problem 2 if the Vin is changed to + 1.5 V. (2 points)

- Calculate VB in the circuit seen at the right. As always show your work for credit. Verify your hand calculations using LTspice. (2 points)

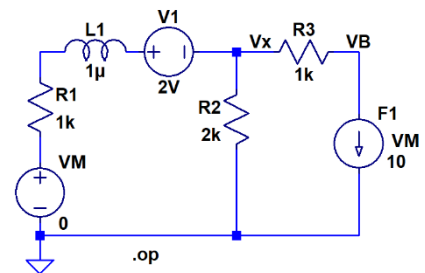

- Calculate Vout in the following circuit. Verify your calculations using LTspice. (2 points)

