

Show your work for credit!

1. Calculate, and plot along with (on the same plot) the voltage seen below, the current flowing in the following circuit using the integral relationship between the voltage across an inductor and the current through the inductor. Verify your hand calculations and plot using LTspice. (4 points)

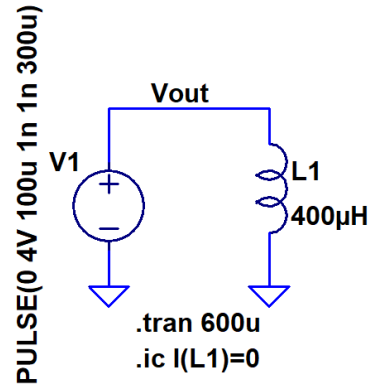
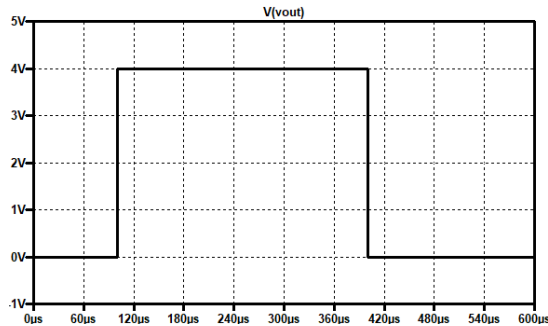

2. Suppose that a linearly rising voltage is used to magnetize an inductor, L . What will the current through the inductor look like? Why? Provide an example using LTspice to support your answer. (3 points)
3. Repeat problem 2 if the polarity of the voltage across the inductor is reversed. (2 points)
4. Show using equations, in problem 3 of HW#15, that the time it takes V_c to reach half of the input pulse amplitude, that is, 2V, is approximately $0.7RC$ or 70 μs . Verify your answer using LTspice (3 points)
5. Show, using $V = L \frac{di}{dt}$, that inductors in series are combined like resistors in series. (2 points)
6. Show, using $i = \frac{1}{L} \int v \cdot dt$, that inductors in parallel are combined like resistors in parallel. (2 points)