

Show your work for credit!

- Find the voltages and currents in the following circuit using any method you would like. Verify your hand calculations using LTspice. (4 points)

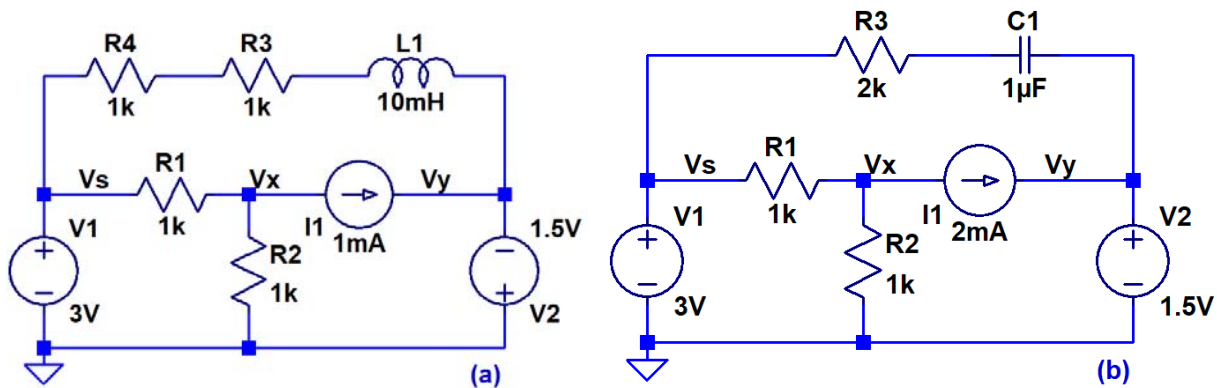

- Write the equations and sketch along with the input pulse (on the same plot), for each of the input pulse's transitions, for the output voltage for each of the following circuits. Make sure you indicate the times the equation is valid. Verify your answers using LTspice. (4 points)

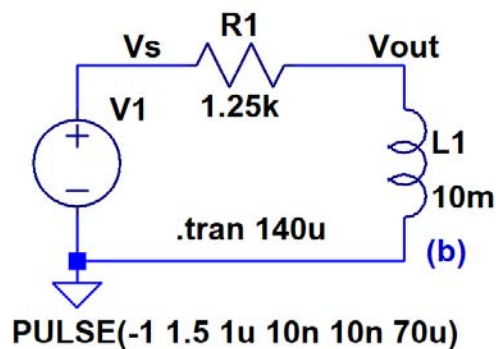
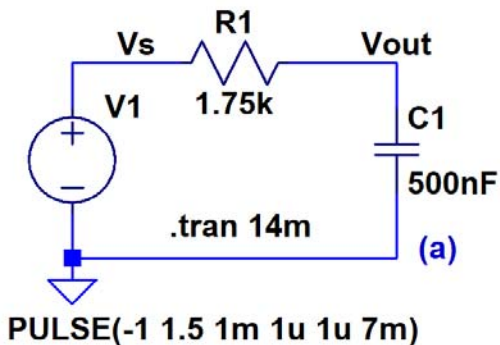

- For the circuits in problems 1 of HW #15 and HW #17 use KVL to write the differential equations describing the circuits' operation. Show how to solve these ordinary differential equations using separation of variables to determine the time-domain equation for V_r . Make sure you are clear on how you handle the initial conditions (initial voltage across the capacitor and current through the inductor). (4 points)
- In the following circuit the input pulse has a peak-to-peak amplitude of 5 V, a DC offset of 2.5 V, and a frequency of 10 MHz (this is what you dial-in on the function generator in the lab). The capacitor removes the DC component of the input signal so this use of the capacitor is called AC coupling. Show, and discuss in your own words, that for high input frequencies ($1/f = T \ll RC$) the capacitor charges very little so the change in the input equals the change in the output. In other words for these fast moving signals the capacitor behaves like a wire (a short). Note the initial condition in the simulation. The RC time constant is 10 ms so for the circuit to reach steady state one has to wait 50 ms (show this in simulations by removing the `.ic` statement and simulating for 50 ms, which will take a long time!). (3 points)

