

Show your work for credit!

- Calculate the voltage across R4 in the below circuits. Next find the Thevenin and Norton equivalent circuits at the port indicated by the red dots in the below schematics (this means without R4 in the circuit). Show that your equivalent circuits are correct and then verify with LTspice. (6 points)

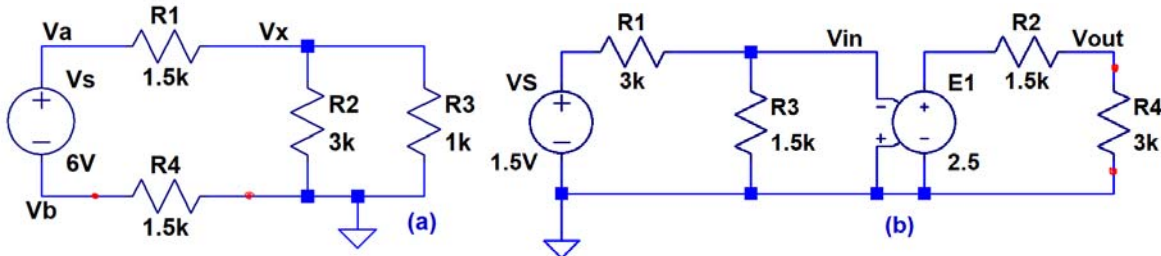

- Find the voltage VB in the following circuit. Verify your answer with LTspice. (3 points)

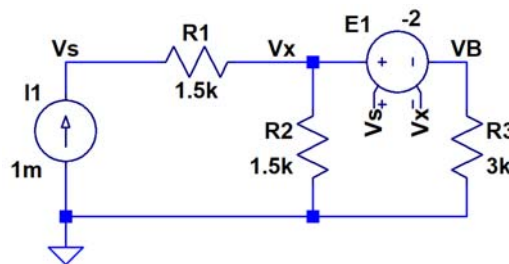

- Find Vout in the following circuit. For all intents and purposes you can assume the gain of the VCVS is infinite. (3 points)

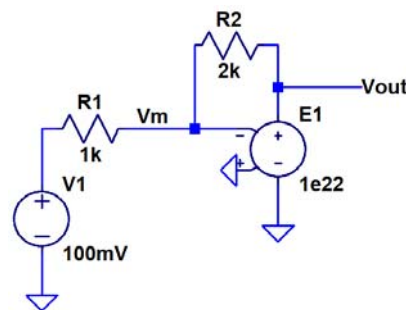

- Find Vout in the following circuit. Verify your answer with LTspice. As always, show your work for credit. (2 points)

