

## Problem 8.1

### *Part 1:*

A Joule of energy is defined as:

$$\text{Joule} = (\text{Watt})(s)$$

So we can express the cost per Joule as:

$$\frac{\$0.25}{\text{kW} \cdot \text{hour}} = \frac{x}{\text{Joule}} \Rightarrow x = \$0.25 \cdot \frac{\text{J}}{\text{kW}} \cdot \frac{\text{hour}}{\text{hour}} = \$69.44 \times 10^{-9}$$

Energy from the power company therefore costs 69.44 nano-dollars per Joule.

### *Part 2:*

The energy supplied to the 100W light bulb is given by:

$$E(t) = \int_{t_1}^{t_2} p(t) dt = \int_0^{3600} (100W) dt = (100W)(3600s) = 360kJ$$

### *Part 3:*

The power company delivers energy so it sells you kinetic energy.

## Problem 8.2

### *Part 1*

If the RMS value of a waveform is 120V, then the amplitude is:

$$120V_{RMS} \left( \frac{\sqrt{2}V}{V_{RMS}} \right) = 120\sqrt{2}V \approx 169.7V$$

The amplitude is related to the peak-to-peak voltage by a factor of two:

$$120\sqrt{2}V(2) = 240\sqrt{2}V \approx 339.4V$$

### *Part 2*

With a frequency resolution of 10Hz, we will get a peak power spectral density of  $120V^2/10Hz \Rightarrow 1440V^2/Hz = 38V/\sqrt{Hz}$  across a 10Hz bandwidth centered at 60Hz. However, if the signal analyzer or FFT bins frequencies every 10Hz, and this is right between two frequency bins then we expect to see half this power in the 50Hz-60Hz bin and the other half in the 60Hz to 70Hz bin with an amplitude of  $720V^2/Hz = 27V/\sqrt{Hz}$ . Integrating this over the entire frequency range, you see  $720V^2/Hz$  PSD from 50Hz to 70Hz  $\rightarrow 720V^2/Hz * 20Hz = 14400V^2 = 120V_{rms}$ .

### Problem 8.3

As defined in equation (8.10), the RMS value the noise-equivalent sinusoidal voltage is:

$$V_{RMS} = \sqrt{v^2} = \int_{f_L}^{f_H} V_{noise}^2(f) df$$
$$\Rightarrow V_{RMS} = \sqrt{\int_0^{1MHz} \left( \frac{1\mu V}{\sqrt{Hz}} \right)^2 df} = \sqrt{\left( \frac{10^{-12} V^2}{Hz} \right) (1MHz)} = \sqrt{10^{-6} V^2} = 0.001 V_{RMS}$$

## Problem 8.4

Assuming a single-pole roll-off, we can use equation (8.15):

$$V_{RMS}^2 = V_{LF,noise}^2(f) \cdot f_{3dB} \cdot \frac{\pi}{2} \Rightarrow V_{RMS}^2 = \left( \frac{1\mu V}{\sqrt{Hz}} \right)^2 (5MHz) \frac{\pi}{2} = 7.85 \times 10^{-6} V^2$$
$$\Rightarrow V_{RMS} = \sqrt{7.85 \times 10^{-6} V^2} = 2.8 \times 10^{-3} V_{RMS}$$

## Problem 8.5

For noise calculations, we ground our input  $V_s$ . Looking from the output, we see an equivalent resistance of:

$$R_{EQ} = (1k\Omega) \parallel [1k\Omega + (1k\Omega) \parallel (1k\Omega)] = 600\Omega$$

The representative noise voltage source then is:

$$V_{R,RMS}^2(f) = 4kTR_{EQ} = 4 \cdot \left(1.38 \times 10^{-23} \frac{J}{^\circ K}\right) \cdot (300^\circ K)(600\Omega) = 9.94 \times 10^{-18} \frac{V^2}{Hz}$$

This is simply white noise, which can be summed over a bandwidth just as in problem 8.3. Note also that the noise voltage source is the noise output as well.

$$V_{OUT,RMS}^2 = \int_0^{1kHz} \left(9.94 \times 10^{-18} \frac{V^2}{Hz}\right) df = 9.94 \times 10^{-15} V^2$$

The SPICE result is:

```
Circuit: *** problem 8.5 ***  
  
TEMP=27 deg C  
Noise analysis ... 100%  
onoise_total = 9.935508e-15
```

Note that SPICE divides onoise\_total by  $V^2$ . The netlist is seen below.

```
*** problem 8.5 ***  
  
.control  
destroy all  
run  
print onoise_total  
.endc  
.noise      v(vout)    vin  dec  100  1    1k  
  
vin  vin  0    dc    0    ac    1  
r1   vt   0    1k  
r2   vt   0    1k  
r3   vt   vout 1k  
r4   vout 0    1k  
.end
```

8.6 Estimate the RMS output noise over an infinite bandwidth for the circuit in Fig. 8.48 if the output is shunted with a 1pF capacitor.

Circuit in question:

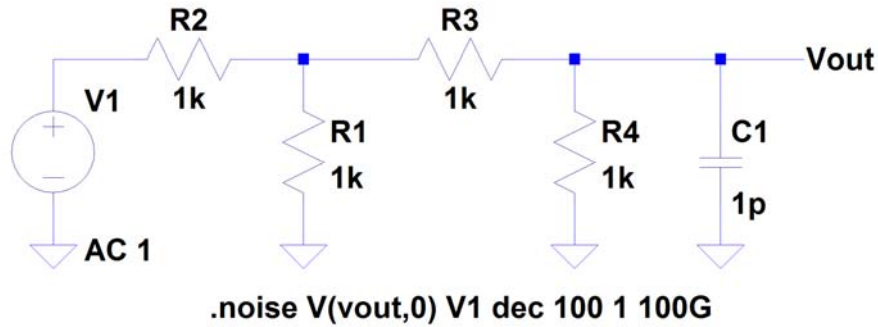

Figure 1. Circuit examined.

If we Thevinize the circuit at the 1pF load we arrive at the following:

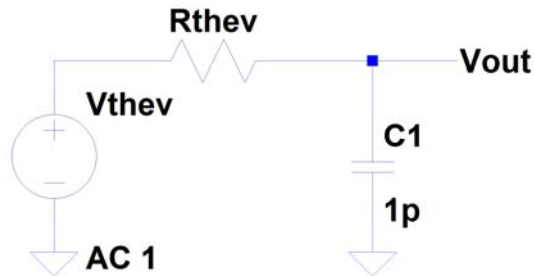

Figure 2. Thevinized circuit.

We don't care the value of the equivalent resistance because we can readily see now that

$$V_{\text{ONOISE,RMS}} = \sqrt{\frac{kT}{C}} \cdot C = 1\text{pF} \text{ so } V_{\text{ONOISE,RMS}} = 64\mu\text{V}. \text{ (Table 8.1, page 229)}$$

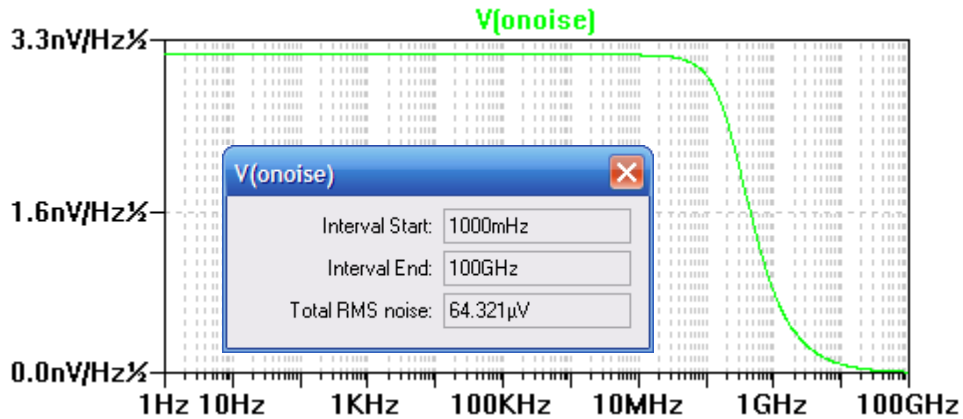

Figure 3. Simulation results for noise analysis of circuit in Fig. 1.

## Problem 8.7

We can break up this problem into two parts: the calculation of  $SNR_{IN,V}$  (the SNR when using an input voltage source) and the calculation of  $SNR_{IN,I}$  (the SNR when using an input current source). We start with  $SNR_{IN,V}$ .

Because superposition allows us to analyze the effect of the  $V_{S,RMS}$  and the noise voltage source separately, we have:

$$\begin{aligned} \text{Desired Signal Power} &= \left[ V_{S,RMS} \cdot \frac{R_{IN}}{R_{IN} + R_S} \right]^2 \\ \text{Undesired (Noise) Power} &= 4kTR_S \left( \frac{R_{IN}}{R_{IN} + R_S} \right)^2 \\ SNR_{IN,V} &= \frac{\text{Desired Signal Power}}{\text{Undesired (Noise) Power}} = \frac{\left[ V_{S,RMS} \cdot \frac{R_{IN}}{R_{IN} + R_S} \right]^2}{4kTR_S \left( \frac{R_{IN}}{R_{IN} + R_S} \right)^2} = \frac{V_{S,RMS}^2}{4kTR_S} \end{aligned}$$

This was derived also on page 8-18. If we choose to use the input current source instead of the voltage source, we obtain:

$$\begin{aligned} \text{Desired Signal Power} &= \left[ I_{S,RMS} \cdot \frac{R_{IN} R_S}{R_{IN} + R_S} \right]^2 \\ \text{Undesired (Noise) Power} &= \frac{4kT}{R_S} \left( \frac{R_{IN} R_S}{R_{IN} + R_S} \right)^2 \\ SNR_{IN,I} &= \frac{\text{Desired Signal Power}}{\text{Undesired (Noise) Power}} = \frac{\left[ I_{S,RMS} \cdot \frac{R_{IN} R_S}{R_{IN} + R_S} \right]^2}{\frac{4kT}{R_S} \left( \frac{R_{IN} R_S}{R_{IN} + R_S} \right)^2} = \frac{I_{S,RMS}^2}{4kT/R_S} \end{aligned}$$

So if the SNR's are equal we must have:

$$\frac{V_{S,RMS}^2}{4kTR_S} = \frac{I_{S,RMS}^2}{4kT/R_S}$$

And, in fact this is true because of the relationship  $V_{S,RMS}^2 = I_{S,RMS}^2 R_S^2$ . Thus  $SNR_{IN,V} = SNR_{IN,I}$ .

8.8 Using the input-referred noise model seen in Fig. 8.20b, verify that if the input resistance becomes infinite, the output noise is adequately modeled using a single input-referred noise voltage.

The solution for output noise for the circuit in Fig. 8.20b is found in (8.32). This solution is as follows

$$V_{noise,RMS}^2 = 4kTR_s B \cdot \left( \frac{AR_{in}}{R_s + R_{in}} \right)^2 + I_{noise,RMS}^2 \cdot \left( \frac{AR_s R_{in}}{R_s + R_{in}} \right)^2 + V_{noise,RMS}^2 \cdot \left( \frac{AR_{in}}{R_s + R_{in}} \right)^2$$

$$\lim_{R_{in} \rightarrow \infty} V_{noise,RMS}^2 = 4kTR_s B \cdot A^2 + I_{noise,RMS}^2 \cdot A^2 R_s^2 + V_{noise,RMS}^2 \cdot A^2$$

Clearly this solution shows that the input referred noise model *does not* drop out of the equation when  $R_{in} = \infty$  unless  $R_s$  also equals 0. We cannot verify as the problem asks.

## Problem 8.9

An NF of zero doesn't indicate that the amplifier's output is noise-free, nor does it indicate the output is noisy. It does mean that the amplifier isn't introducing any *new* noise into the signal. Thus, a noisy signal input produces a noisy signal output, and a clean signal input produces a clean signal output.

## Problem 8.10

Using the circuit seen in Fig. 8.20b and setting  $V_S = 0$  and eliminating the  $R_S$  noise voltage (because we are calculating power due to the input-referred sources), we can see that the power to  $R_{IN}$  is:

$$P_{IN} = \left( V_{noise,RMS} \frac{R_{IN}}{R_{IN} + R_S} \right)^2 / R_{IN} + \left( I_{noise,RMS} \frac{R_S}{R_{IN} + R_S} \right)^2 R_{IN}$$

If we let  $R_{IN} = R_S = R$  (otherwise the power input to  $R_{IN}$  will be dependent on  $R_S$ ; and we want maximum power transfer, that is,  $R_S = R_{IN}$ ):

$$P_{IN} = \left( V_{noise,RMS} \frac{1}{2} \right)^2 / R + \left( I_{noise,RMS} \frac{1}{2} \right)^2 R$$

But  $V_{noise,RMS} = I_{noise,RMS} R$ , so we have:

$$P_{IN} = \left( V_{noise,RMS} I_{noise,RMS} \frac{1}{4} \right) + \left( V_{noise,RMS} I_{noise,RMS} \frac{1}{4} \right) = \frac{1}{2} V_{noise,RMS} I_{noise,RMS}$$

### Problem 8.11

Equation (8.49) states:

$$I_{shot}^2(f) = 2qI_{DC}$$

The units then are:

$$Q \cdot \frac{Q}{T} = \frac{Q^2}{T}$$

Where Q is charge and T is time. Then through simple algebraic manipulation:

$$\frac{Q^2}{T} = \frac{Q^2}{T} \frac{T}{T} = \frac{Q^2}{T^2} T = \left(\frac{Q}{T}\right)^2 T = A^2 T = A^2 \frac{1}{1/T} = A^2 / Hz$$

## Problem 8.12

Our  $1k\Omega$  resistor still exhibits the same thermal noise characteristics:

$$\bar{i}_R^2 = \frac{4kT}{R} = 1.667 \times 10^{-23} \text{ A}^2/\text{Hz}$$

Assume 0.7V drop across diode:

$$r_d = V_T / I_{DC} \frac{kT}{qI_{DC}} = \frac{k \cdot 300^\circ \text{K}}{q \cdot 0.3\text{mA}} = 86.2\Omega$$

$$C_d = \frac{\tau_T}{r_d} = 116\text{pF}$$

The new shot noise is then:

$$\bar{i}_{shot}^2 = 2qI_{DC} = 9.61 \times 10^{-23} \text{ A}^2/\text{Hz}$$

Examining the noise circuit of example 8.12, we see that the two resistances can be combined and the two current sources can be combined. Then it is straightforward to see that we have a single-pole roll-off present in our circuit. This configuration allows us to employ the noise-equivalent bandwidth approach.

$$R_{eq} = (1k\Omega) \parallel (86.2\Omega) = 79.36\Omega$$

$$\bar{i}_{eq}^2 = \bar{i}_{shot}^2 + \bar{i}_R^2 = (9.61 \times 10^{-23} \text{ A}^2/\text{Hz} + 1.66 \times 10^{-23} \text{ A}^2/\text{Hz}) = 11.27 \times 10^{-23} \text{ A}^2/\text{Hz}$$

Our low-frequency output voltage then is:

$$V_{out,RMS}^2(f) = \bar{i}_{eq}^2 R_{eq}^2 = (11.27 \times 10^{-23} \text{ A}^2/\text{Hz})(79.36\Omega)^2 = 7.10 \times 10^{-19} \text{ V}^2/\text{Hz}$$

The noise-equivalent bandwidth is:

$$NEB = \frac{\pi}{2} \frac{1}{2\pi RC} = \frac{1}{4} \frac{1}{RC} = \frac{1}{4(79.36\Omega)(116\text{pF})} = 27.16 \text{ MHz}$$

Integrating the output noise voltage over an infinite bandwidth:

$$\begin{aligned} V_{out,RMS}^2 &= \int_0^\infty V_{out,RMS}^2(f) df = V_{out,RMS}^2(f) \cdot NEB \\ &= (7.10 \times 10^{-19} \text{ V}^2/\text{Hz})(27.16 \text{ MHz}) = 1.92 \times 10^{-11} \text{ V}^2 \end{aligned}$$

The output voltage then is:

$$V_{out,RMS} = \sqrt{1.92 \times 10^{-11} \text{ V}^2} = 4.39 \mu\text{V} \text{ (RMS)}$$

Using SPICE we obtain:

```
TEMP=27 deg C
Noise analysis ... 100%
onoise_total = 1.540263e-11
```

$$V_{out,RMS} |_{SPICE} = 3.92 \mu\text{V} \text{ (RMS)}$$

The difference between the hand calculations and SPICE is about half of a microvolt. Note that the hand calculations could be improved by using an improved guess at  $I_{DC}$  rather than just assuming it is 0.7V. This is accomplished through the use of a ".op" analysis in SPICE.

The hand calculations were done using 0.629 as the diode-drop and the new output voltage was found to be:

$$V_{out,RMS} |_{improved} = 4.19 \mu\text{V}$$

This is an improvement over the original calculation. However, one might question the ironic use of a computer to aid hand calculations. The SPICE netlist can be found below.

```
*** problem 8.12 ***

.control
destroy all
run
print all
.endc

.noise      v(vout,0) vs      dec  100  1      100G
*.op

vs      vs      0      dc      1.0      ac      1
rs      vs      vout 1k
d1      vout 0      diode

.model      diode      d      tt=10n      rs=0
.print      noise      all
.end
```

### Problem 8.13

The power spectral density of our signal is of the form:

$$V_{out,RMS}^2(f) = \frac{FNN}{f^3} V^2/Hz$$

The constant  $FNN$  simply depends on the particular noise phenomenon being described. Regardless, the output voltage will be:

$$\begin{aligned} V_{out,RMS} &= \sqrt{\int_{f_L}^{f_H} V_{out,RMS}^2(f) df} \\ &= \sqrt{\int_{f_L}^{f_H} \frac{FNN}{f^3} df} = \sqrt{\frac{FNN}{2f_L^2} - \frac{FNN}{2f_H^2}} \end{aligned}$$

Not surprisingly, if we take the limit as  $f_H \rightarrow \infty$ , our output becomes:

$$\lim_{f_H \rightarrow \infty} \sqrt{\frac{FNN}{2f_L^2} - \frac{FNN}{2f_H^2}} = \sqrt{\frac{FNN}{2f_L^2}}$$

Using equation (8.52) in conjunction with the above result, we can see that:

$$V_{out,RMS} = \sqrt{\frac{FNN}{2} \left( \frac{1}{1/T_{meas}} \right)^2} = T_{meas} \sqrt{\frac{FNN}{2}}$$

Thus, if we are measuring an input signal containing  $f^{-3}$  noise, we will see the output voltage increase linearly with time. One way this type of noise manifests itself is integrating regular flicker ( $f^{-1}$ ) noise.

8.14 If the maximum allowable RMS output noise of a transimpedance amplifier built using the TLC220x is  $100\mu\text{V}$  in a bandwidth of  $1\text{MHz}$  is needed, what are the maximum values of  $C_F$  and  $R_F$ ? What is the peak-to-peak value of the noise in the time domain?

In this topology all of the input referred noise voltage inherent to the op-amp (both thermal and flicker) makes it to the output (a gain of 1) and both are bandlimited by the unity gain frequency of the op-amp, or  $2\text{MHz}$  (not the  $f_{3\text{dB}}$  of the feedback). The TLC220x has an input referred flicker noise voltage spectral density of  $56\text{nV}/\sqrt{\text{Hz}}$ . The input referred thermal noise voltage spectral density of the amp is  $8\text{nV}/\sqrt{\text{Hz}}$ . These values come from Fig. 8.31. We will soon see that they do not factor into the solution (much) due to being orders of magnitude less than the noise from the RC feedback network.

The feedback network adds  $kT/C$  noise to the circuit.

We have:

$$V_{\text{noise}}^2(f) = \frac{(56E-9)^2}{f} + (8E-9)^2 + (RC_{\text{feedback,noise}})^2$$

$$= \frac{3.14E-15}{f} + 64E-18 + (RC_{\text{feedback,noise}})^2$$

We can now set up the equation to solve for output RMS noise.

$$V_{\text{noise,RMS}} = 100E-6 = \sqrt{3.14E-15 \cdot 49 + 64E-18 \cdot 2E6 \cdot \frac{\pi}{2} + \frac{4.14E-21}{C}}$$

$$10E-9 = 154E-15 + 201E-12 + \frac{4.14E-21}{C}$$

We see from the last equation that the amps flicker and thermal RMS noise contributions are small.

Solving for C we find **C = 422fF**.

We can now say that  $f_{3\text{dB}} = 1\text{MHz} = \frac{1}{2\pi RC}$ . Knowing C we can solve for R. **R = 377kΩ**.

In the time domain we know that  $V_{\text{RMS}} = \sigma$  and  $V_{\text{p-p}} = 6\sigma$ .

$V_{\text{RMS}} = 100\mu\text{V} = \sigma$ ;  $V_{\text{p-p}} = \mathbf{600\mu\text{V}}$ .

8.15

The noise circuit is seen below. Both sides of the 1k resistor are at ground so that the noise from the 1k flows through the feedback resistor and capacitor to generate output noise.

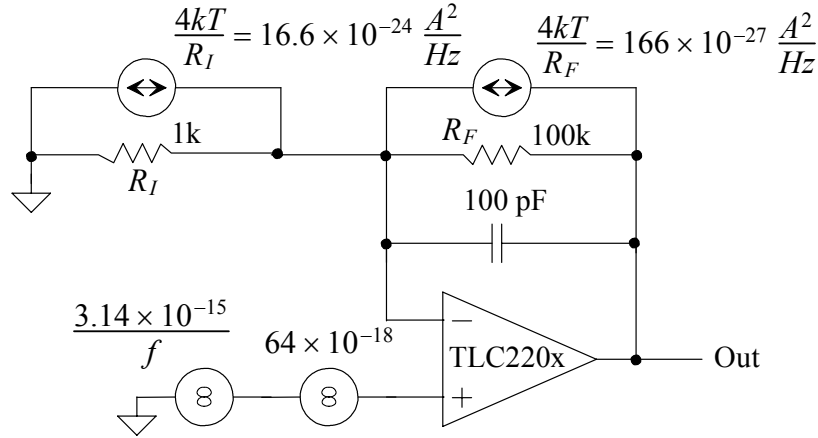

$$V_{noise}^2(f) = \left[ \frac{3.14 \times 10^{-15}}{f} + 64 \times 10^{-18} \right] \cdot \left[ 1 + \frac{R_F}{R_I} \right]^2 + \left[ \frac{4kT}{R_F} + \frac{4kT}{R_I} \right] \cdot \left| \frac{R_F \cdot 1/j\omega C_F}{R_F + 1/j\omega C_F} \right|^2$$

and

$$V_{noise}^2(f) = \left[ \frac{3.14 \times 10^{-15}}{f} + 64 \times 10^{-18} \right] \cdot \left[ 1 + \frac{R_F}{R_I} \right]^2 + \left[ \frac{4kT}{R_F} + \frac{4kT}{R_I} \right] \cdot \frac{R_F^2}{1 + (\omega R_F C_F)^2}$$

or

$$V_{noise}^2(f) = \left[ \frac{3.14 \times 10^{-15}}{f} + 64 \times 10^{-18} \right] \cdot \left[ 1 + \frac{R_F}{R_I} \right]^2 + \left[ 1 + \frac{R_F}{R_I} \right] \cdot \frac{4kTR_F}{1 + (\omega R_F C_F)^2}$$

Following the info on pages 250 and 251, and noting that now the op-amp noise is no longer negligible compared to the  $kT/C$  noise, we get (with  $1 + R_F/R_I = 101$  and  $C_F = 100$  pF)

$$V_{noise,RMS}^2 = \underbrace{49 \cdot 3.14 \times 10^{-15} \cdot 101^2}_{=1.57 \times 10^{-9}} + \underbrace{64 \times 10^{-18} \cdot 101^2 \cdot \frac{\pi}{2} \cdot 1.59 \text{ kHz}}_{=1.63 \times 10^{-9}} + \underbrace{\frac{kT}{C_F} \cdot 101}_{=4.18 \times 10^{-9}}$$

or

$$V_{noise,RMS}^2 = 7.38 \times 10^{-9} V^2 \rightarrow V_{noise,RMS} = 86 \mu V$$

If the op-amp is ideal then the RMS output voltage is approximately

$$V_{noise,RMS} \approx \sqrt{1 + \frac{R_F}{R_I}} \cdot \sqrt{\frac{kT}{C}} = 10 \cdot 6.4 \mu V = 64 \mu V$$

The netlist (using an ideal op-amp) is seen on the next page. The simulations match the hand calculations.

SPICE for problem 8.15

```
.control  
destroy all  
run  
let vonoiserms=sqrt(onoise_total)  
print vonoiserms  
.endc
```

```
.noise V(Vout,0) Vin dec 100 1 1G
```

```
Vin Vin 0 dc 0 ac 1
```

```
Ri vin vminus 1k
```

```
Rf Vout Vminus 100k
```

```
Cf Vout Vminus 100pf
```

\* use a voltage-controlled voltage source (E source) for the ideal op-amp

```
Eopamp Vout 0 0 Vminus 100MEG
```

```
.end
```

Problem 8.16

The DC current flowing in the circuit is

$$I_{DC} = \frac{9 - 4.7}{1k} = 4.3 \text{ mA}$$

The shot noise current produced by the diode is

$$I_{shot}^2(f) = 2q \cdot 4.3 \text{ mA} = 1.38 \times 10^{-21} \frac{\text{A}^2}{\text{Hz}}$$

Assuming the 1k resistor is  $\ll$  than the diode's small-signal Zener resistance,  $r_z$ , the output noise PSD is

$$V_{out}^2(f) = I_{shot}^2(f) \cdot R^2 = 1.38 \times 10^{-21} \frac{\text{A}^2}{\text{Hz}} \cdot 10^6 = 1.38 \times 10^{-15} \frac{\text{V}^2}{\text{Hz}}$$

If the Zener resistance is comparable or less than the 1k resistor then

$$V_{out}^2(f) = I_{shot}^2(f) \cdot (1k || r_z)^2 = 1.38 \times 10^{-21} \frac{\text{A}^2}{\text{Hz}} \cdot (1k || r_z)^2$$

### Problem 8.17

Our  $Z_{IN}$  is now:

$$Z_{IN} = R_{IN} + \frac{1}{j\omega C_{IN}}$$

So, using the left-hand side of equation (8.72) with our new  $Z_{IN}$ :

$$\begin{aligned} |R_S + Z_{IN}|^2 &= \left| R_S + R_{IN} + \frac{1}{j\omega C_{IN}} \right|^2 = \left[ \sqrt{(R_S + R_{IN})^2 + \left( \frac{1}{\omega C_{IN}} \right)^2} \right]^2 \\ &= (R_S + R_{IN})^2 + \left( \frac{1}{\omega C_{IN}} \right)^2 \end{aligned}$$

## Problem 8.18

This problem can be solved with the help of equation (8.82), Figure 8.47, and the knowledge of  $f_u$ . The unity-gain frequency is stated on page 8-49 as:

$$f_u = 70 \text{ MHz}$$

Estimating off of Figure 8.47, we see that:

$$V_{noise}(f) = 9 \frac{nV}{\sqrt{Hz}}$$

$$I_{noise}(f) = 0.85 \frac{pA}{\sqrt{Hz}}$$

Using equation (8.82):

$$V_{noise,RMS} =$$

$$= \left[ \left( 9 \frac{nV}{\sqrt{Hz}} \right) \left( \frac{1k\Omega + 100k\Omega}{1k\Omega} \right) + \left( 0.85 \frac{pA}{\sqrt{Hz}} \right) \left( 100k\Omega + \sqrt{4kT \cdot 100k\Omega} + \frac{100k\Omega}{1k\Omega} \sqrt{4kT \cdot 1k\Omega} \right) \right] \sqrt{\frac{\pi}{2} (70MHz) \frac{1k\Omega}{1k\Omega + 100k\Omega}}$$

$$= 1.5mV \text{ (RMS)}$$

Placing a capacitor across the feedback resistance would reduce the gain of the op-amp at higher frequencies. To have a significant effect the feedback capacitor would have to cause the op-amp to roll-off at a smaller frequency compared to the internal compensation of the op-amp. In other words:

$$\frac{1}{2\pi R_2 C_F} \ll \left( 1 + \frac{R_2}{R_1} \right) f_u$$

The first way to lower the output noise is mentioned above. Using a feedback capacitor lowers the noise at the expense of gain or bandwidth. Another way to reduce output noise is to use smaller resistances. However, this causes greater power dissipation in the resistors.